

# Variable Displacement Motor A6VM

**RE 91 604/05.99**  
replaces: 12.95

for open and closed circuits

Sizes 28...1000  
Series 6  
Nominal pressure 400 bar  
Peak pressure 450 bar

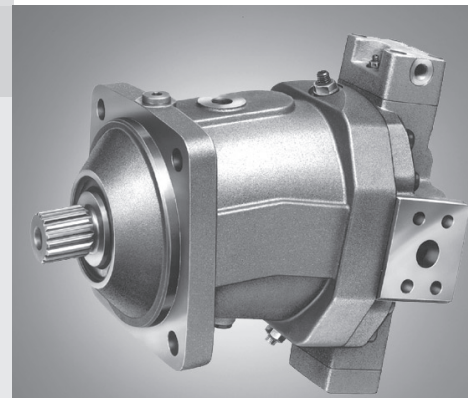

## Index

Features	1
Ordering Code / Standard Program	2...3
Technical Data	4...7
DA - Hydraulic Control, Speed Related	8...9
HA - Automatic Control, High Pressure Related	10...13
HD - Hydraulic Control, Pilot Pressure Related	14...17
HZ - Hydraulic Two-Position Control	18
EZ - Electrical Two-Position Control, with Switching Solenoid	19
EP - Electrical Control, with Proportional Solenoid	20...22
Unit Dimensions Size 28	23
Unit Dimensions Size 55	24
Unit Dimensions Size 80	25
Unit Dimensions Size 107	26
Unit Dimensions Size 140	27
Unit Dimensions Size 160	28
Unit Dimensions Size 200	29
Unit Dimensions Size 250	30
Unit Dimensions Size 355	31
Unit Dimensions Size 500	32
Unit Dimensions Size 1000	33
Winch Motion Control Valve MHB...E, Simple Function	34
Drive Motion Control Valve MHB...R, Double Function	35
Flushing and Boost Pressure Valve	36
Speed Sensor	37
Swivel Angle Indicator	38
Preference Types	39

## Features

- Variable displacement motor with axial piston rotary group of bent axis design, for hydrostatic drives in open and closed circuits.
- The motor is suitable for both mobile and industrial applications.
- The wide control range of the variable displacement motor allows it to meet the requirements of high speed and high torque.
- The displacement is infinitely variable in the range  $V_{g \max}$  to  $V_{g \min} = 0$ .
- Output speed is proportional to flow and inversely proportional to displacement.
- The output torque increases with the pressure drop between the high and low pressure sides and with increasing displacement.
- Wide control range for hydrostatic drives
- Various control and regulating devices
- Cost saving through elimination of gearbox and possibility of using smaller motors
- Compact, robust bearing system with long service life
- Low unit power
- Good starting characteristics
- Low inertia
- Wide swivel range

### Ordering Code / Standard Program

#### Hydraulic fluid

Mineral oil (no code)	
HF-fluids	sizes 28...200 (no code)
	sizes 250...1000 (only in connection with drive shaft bearings "L")
	<b>E</b>

#### Axial piston unit

Bent axis design, variable displacement	<b>A6V</b>
---	------------

#### Drive shaft bearings

	28...200	250...500	1000	
Mechanical bearings (no code)	●	●	-	
Long-Life bearings	-	●	●	<b>L</b>

#### Mode of operation

Motor (plug-in motor A6VE see RE 91606)	<b>M</b>
---	----------

#### Size

≅ Displacement $V_{g,max}$ (cm <sup>3</sup> )	<b>28</b>	<b>55</b>	<b>80</b>	<b>107</b>	<b>140</b>	<b>160</b>	<b>200</b>	<b>250</b>	<b>355</b>	<b>500</b>	<b>1000</b>
---	-----------	-----------	-----------	------------	------------	------------	------------	------------	------------	------------	-------------

Sizes 28...200: production plant Elchingen; Sizes 250...1000: production plant Horb

#### Control device

			28	55	80	107	140	160	200	250	355	500	1000	
Hydraulic control pilot pressure increase pilot pressure related	10 bar	<b>HD1</b>	●	●	●	●	●	●	●	●	●	●	●	<b>HD1</b>
	25 bar	<b>HD2</b>	●	●	●	●	●	●	●	●	●	●	●	<b>HD2</b>
	35 bar	<b>HD3</b>	-	-	-	-	-	-	-	●	○	●	○	<b>HD3</b>
Hydraulic two-position control		<b>HZ</b>	-	-	-	-	-	-	-	●	●	●	●	<b>HZ</b>
		<b>HZ1</b>	●	-	-	-	●	●	●	-	-	-	-	<b>HZ1</b>
		<b>HZ3</b>	-	●	●	●	-	-	-	-	-	-	-	<b>HZ3</b>
Electrical control, with proportional solenoid	control voltage	12 V	<b>EP1</b>	●	●	●	●	●	●	●	●	●	○	<b>EP1</b>
		24 V	<b>EP2</b>	●	●	●	●	●	●	●	●	●	○	<b>EP2</b>
Electrical two-position control, with switching solenoid	control voltage	12 V	<b>EZ1</b>	●	-	-	-	●	●	●	●	●	●	<b>EZ1</b>
		24 V	<b>EZ2</b>	●	-	-	-	●	●	●	●	●	●	<b>EZ2</b>
		12 V	<b>EZ3</b>	-	●	●	●	-	-	-	-	-	-	<b>EZ3</b>
		24 V	<b>EZ4</b>	-	●	●	●	-	-	-	-	-	-	<b>EZ4</b>
Automatic control, high pressure related	without pressure increase	<b>HA1</b>	●	●	●	●	●	●	●	●	●	●	○	<b>HA1</b>
	with pressure increase $\Delta p = 100$ bar	<b>HA2</b>	●	●	●	●	●	●	●	●	●	●	○	<b>HA2</b>
Hydraulic control, speed related		<b>DA</b>	-	-	-	-	-	-	-	●	●	●	○	<b>DA</b>
$p_{st}/p_{HD} = 5/100$ , hydraulic valve for travel direction		<b>DA1</b>	●	●	●	●	●	●	●	-	-	-	-	<b>DA1</b>
	electrical valve for travel direction	12 V	<b>DA2</b>	●	●	●	●	●	●	-	-	-	-	<b>DA2</b>
	+ electrical $V_{g,max}$ -switch	24 V	<b>DA3</b>	●	●	●	●	●	●	-	-	-	-	<b>DA3</b>
$p_{st}/p_{HD} = 8/100$ , hydraulic valve for travel direction		<b>DA4</b>	●	●	●	●	●	●	●	-	-	-	-	<b>DA4</b>
	electrical valve for travel direction	12 V	<b>DA5</b>	●	●	●	●	●	●	-	-	-	-	<b>DA5</b>
	+ electrical $V_{g,max}$ -switch	24 V	<b>DA6</b>	●	●	●	●	●	●	-	-	-	-	<b>DA6</b>

#### Pressure control (only for HD, EP)

			28	55	80	107	140	160	200	250	355	500	1000	
without pressure control (no code)			●	●	●	●	●	●	●	●	●	●	●	
Pressure control, direct control			●	●	●	●	●	●	●	●	●	●	●	<b>D</b>
direct control, with 2nd pressure setting			●	●	●	●	●	●	●	-	-	-	-	<b>E</b>
remote control			-	-	-	-	-	-	-	●	●	●	●	<b>G</b>

#### Override of HA-control (only for HA1, HA2)

without override (no code)			●	●	●	●	●	●	●	●	●	○		
Hydraulic override			●	●	●	●	●	●	●	●	●	○	<b>T</b>	
Electrical override	control voltage	12 V	●	●	●	●	●	●	●	-	-	-	-	<b>U1</b>
		24 V	●	●	●	●	●	●	●	-	-	-	-	<b>U2</b>
Electrical override + el. valve for travel direction	control voltage	12 V	●	●	●	●	●	●	●	-	-	-	-	<b>R1</b>
		24 V	●	●	●	●	●	●	●	-	-	-	-	<b>R2</b>

#### Series

	<b>6</b>
--	----------

#### Index

	<b>3</b>
--	----------

	<b>A6V</b>	<b>M</b>		<b>/</b>	<b>6</b>	<b>3</b>	<b>W</b>	<b>-</b>	<b>V</b>										
Hydraulic fluid																			
Axial piston unit																			
Drive shaft bearings																			
Mode of operation																			
Size																			
Control device																			
Series																			
Index																			

**Direction of rotation**

viewed on shaft end	alternating	<b>W</b>
---------------------	-------------	----------

**Setting range for displacement <sup>1)</sup>**

28...200 250...1000

$V_{g\ min} = 0$ to $0,8 V_{g\ max}$ (no code)	●	–	
$V_{g\ min} = 0$ to $0,4 V_{g\ max}$	$V_{g\ max} = V_{g\ max}$ to $0,8 V_{g\ max}$	–	● 1
$V_{g\ min} > 0,4 V_{g\ max}$ to $0,8 V_{g\ max}$	$V_{g\ max} = V_{g\ max}$ to $0,8 V_{g\ max}$	–	● 2

**Seals**

28 55 80 107 140 160 200 250 355 500 1000

FKM (fluor-caoutchouc)	●	●	●	●	●	●	●	●	●	●	●	●	<b>V</b>
------------------------	---	---	---	---	---	---	---	---	---	---	---	---	----------

**Shaft end**

Splined shaft DIN 5480	●	●	●	●	–	●	●	–	–	–	–	–	<b>A</b>
	●	●	●	●	●	●	–	●	●	●	●	●	<b>Z</b>
Parallel shaft with key DIN 6885	–	–	–	–	–	–	–	●	●	●	●	●	<b>P</b>

**Mounting flange**

ISO 4-hole	●	●	●	●	●	●	●	–	–	–	–	<b>B</b>
ISO 8-hole	–	–	–	–	–	–	–	●	●	●	●	<b>H</b>

**Service line connections**

28 55 80 107 140 160 200 250 355 500 1000

Ports A, B: SAE rear end (metric threads)	<b>01</b>	0	●	●	●	●	●	●	●	●	●	●	●	●	<b>010</b>
		7	●	●	●	●	●	●	●	●	●	●	●	○	<b>017</b>
Ports A, B: SAE on (opposite) sides (metric threads)	<b>02</b>	0	●	●	●	●	●	●	●	●	●	●	●	●	<b>020</b>
		7	●	●	●	●	●	●	●	●	●	●	○	<b>027</b>	
Port plate for mounting a motion control valve	<b>08</b>	0	–	–	–	–	–	–	–	–	●	–	–	<b>080</b>	
		8	–	–	–	–	–	–	–	–	●	–	–	<b>088</b>	
Ports A, B: SAE on (opposite) sides + rear end	<b>15</b>	0	–	–	–	–	–	–	–	●	○	●	○	<b>150</b>	
Port plate with pressure relief valve, for mounting a motion control valve <sup>2)</sup>	<b>37</b>	0	–	–	–	●	–	–	–	–	–	–	–	<b>370</b>	
		<b>38</b>	0	–	●	●	●	●	●	–	–	–	–	<b>380</b>	

**Valves**

without valve	<b>0</b>
with flushing and boost pressure valve	<b>7</b>
with built-on motion control valve (only for size 250)	<b>8</b>

**Speed sensor**

28 55 80 107 140 160 200 250 355 500 1000

without speed sensor (no code)	●	●	●	●	●	●	●	●	●	●	●	●	
suitable for fitting speed sensor	●	●	●	●	●	●	●	●	●	●	●	○	<b>D</b>

**Swivel angle indicator**

without swivel angle indicator (no code)	●	●	●	●	●	●	●	●	●	●	–	
with optical swivel angle indicator	–	–	–	–	–	–	–	●	●	●	●	<b>V</b>
with electronical swivel angle indicator	–	–	–	–	–	–	–	●	●	●	●	<b>E</b>

**Start of control**

at $V_{g\ min}$ (standard for HA)	●	●	●	●	●	●	●	●	●	●	●	●	<b>A</b>
at $V_{g\ max}$ (standard for HD, HZ, EP, EZ, DA)	●	●	●	●	●	●	●	●	●	●	●	●	<b>B</b>

<sup>1)</sup> indicate in the order displacement setting in clear text:  $V_{g\ min} = \dots \text{ cm}^3$ ,  $V_{g\ max} = \dots \text{ cm}^3$

<sup>2)</sup> only possible in connection with controls HD, HA1, HA2, EP

● = available ○ = in preparation – = not available

**■** = Preferred program (preferred types see page 39)

## Technical Data

### Fluid

We request that before starting a project detailed information about the choice of pressure fluids and application conditions are taken from our catalogue sheets RE 90220 (mineral oil), RE 90221 (environmentally acceptable hydraulic fluids) and RE 90223 (fire resistance fluids, HF).

When using HF- or environmentally acceptable hydraulic fluids possible limitations for the technical data have to be taken into consideration. If necessary please consult our technical department (please indicate type of the hydraulic fluid used for your application on the order sheet).

### Operating viscosity range

In order to obtain optimum efficiency and service life, we recommend that the operating viscosity (at operating temperature) be selected from within the range:

$$v_{\text{opt}} = \text{operating viscosity } 16 \dots 36 \text{ mm}^2/\text{s}$$

referred to the loop temperature (closed circuit) or tank temperature (open circuit).

### Viscosity limits

The limiting values for viscosity are as follows:

Sizes 28...200

$v_{\text{min}} = 5 \text{ mm}^2/\text{s}$ ,  
short term at a max. permissible temperature  $t_{\text{max}} = 115^\circ\text{C}$

$v_{\text{max}} = 1600 \text{ mm}^2/\text{s}$ ,  
short term on cold start ( $t_{\text{min}} = -40^\circ\text{C}$ )

Sizes 250...1000

$v_{\text{min}} = 10 \text{ mm}^2/\text{s}$ ,  
short term at a max. permissible leakage oil temperature  $t_{\text{max}} = 90^\circ\text{C}$

$v_{\text{max}} = 1000 \text{ mm}^2/\text{s}$ ,  
short term on cold start ( $t_{\text{min}} = -25^\circ\text{C}$ )

### Selection diagram

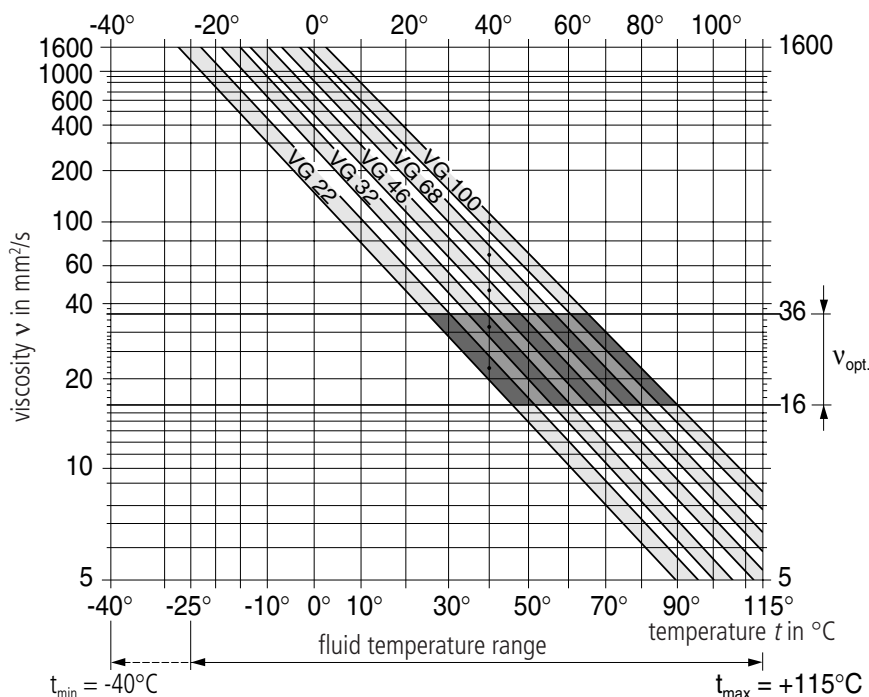

Please note that the max. fluid temperature of  $115^\circ\text{C}$  is also not exceeded in certain areas (for instance bearing area).

At temperatures of  $-25^\circ\text{C}$  up to  $-40^\circ\text{C}$  special measures may be required for certain installation positions. Please contact us for further information.

### Notes on the selection of the hydraulic fluid

In order to select the correct fluid, it is necessary to know the operating temperature in the loop (closed circuit) or the tank temperature (open circuit) in relation to the ambient temperature.

The hydraulic fluid should be selected so that within the operating temperature range, the operating viscosity lies within the optimum range ( $v_{\text{opt}}$ ) (see shaded section of the selection diagram). We recommend that the highest possible viscosity range should be chosen in each case.

Example: At an ambient temperature of  $X^\circ\text{C}$  the operating temperature is  $60^\circ\text{C}$ . Within the operating viscosity range ( $v_{\text{opt}}$ ; shaded area), this corresponds to viscosity ranges VG 46 or VG 68. VG 68 should be selected.

**Important:** The leakage oil (case drain oil) temperature is influenced by pressure and motor speed and is always higher than the circuit temperature. However, at no point in the circuit may the temperature exceed  $115^\circ\text{C}$  for sizes 28...200 or  $90^\circ\text{C}$  for sizes 250...1000.

If it is not possible to comply with the above condition because of extreme operating parameters or high ambient temperatures we recommend housing flushing via port U or use of a flushing valve (see page 36). Please consult us.

## Technical Data

### Filtration

The finer the filtration the better the achieved purity grade of the pressure fluid and the longer the life of the axial piston unit. To ensure the functioning of the axial piston unit a minimum purity grade of:

9 to NAS 1638

18/15 to ISO/DIS 4406 is necessary.

At very high temperatures of the hydraulic fluid (90°C to max. 115°C, not perm. for sizes 250...1000) at least cleanliness class

8 to NAS 1638

17/14 to ISO/DIS 4406 is necessary.

If above mentioned grades cannot be maintained please consult supplier.

### Operating pressure range

Maximum pressure at port A or B (pressure data to DIN 24312)

Sizes 28...200

Nominal pressure $p_N$	400 bar
------------------------	---------

Peak pressure $p_{max}$	450 bar*
-------------------------	----------

\*) Attention: shaft end **Z** with drives of radial force loads at the drive shaft (pinion V-belt drives) necessitate reduction of the nominal pressure to  $p_N = 315$  bar (please contact us).

Sizes 250...1000

Nominal pressure $p_N$	350 bar
------------------------	---------

Peak pressure $p_{max}$	400 bar
-------------------------	---------

With pulsating loads above 315 bar we recommend using the model with splined shaft A (sizes 28...200) or with splined shaft Z (sizes 250...1000).

The sum of the pressures at ports A and B may not exceed 700 bar.

### Direction of flow

clockwise rotation	anti-clockwise rotation
--------------------	-------------------------

<b>A to B</b>	<b>B to A</b>
---------------	---------------

### Speed range

There is no limitation on minimum speed  $n_{min}$ . If uniformity of rotation is required, however, speed  $n_{min}$  should not be allowed to fall below 50 rpm. See table on page 6 for max. permissible speeds.

### Installation position

Optional. The motor housing must be filled with fluid prior the commissioning, and must remain full whenever it is operating.

For extensive information on installation position, please consult our data sheet RE 90 270 before completing your design work.

### Long-Life-bearings (sizes 250...1000)

(for high life expectancy and use of HF-fluids)

The outer dimensions of the axial piston motors are identical to standard design (without long life bearings). The change from standard design to long life bearing system is possible. We recommend to apply bearing flushing at port U.

### Case Drain Pressure

Shaft seal ring **FKM** (fluor-caoutchouc)

The lower the speed and the case drain pressure the higher the life expectation of the shaft seal ring. The values shown in the diagram are permissible loads of the seal ring and shall not be exceeded.

At stationary pressure loads in the range of the max. admissible leakage pressure a reduction of the life experience of the seal ring will result.

For a short period ( $t < 5$  min.) pressure loads up to 5 bar independent from rotational speeds are permissible respectively for sizes 28...200.

Sizes 28...200

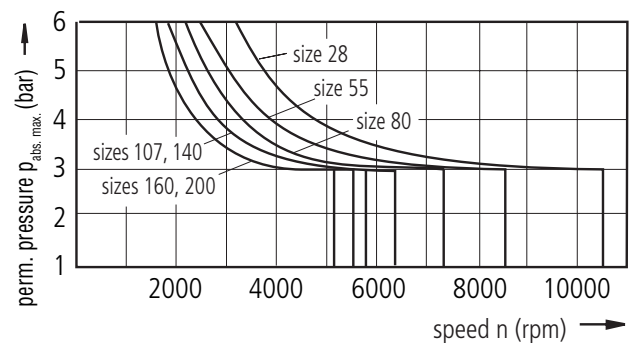

Sizes 250...1000

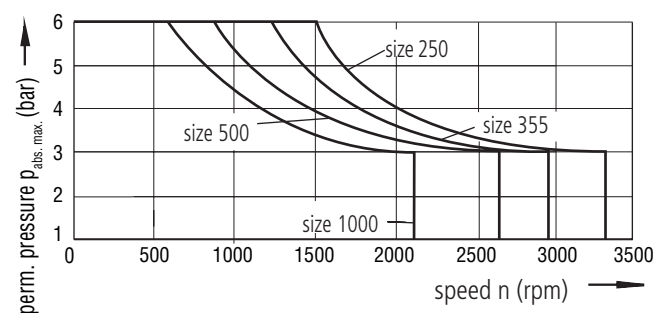

Special operation conditions may require limitations of these values.  
Note:

- max. permissible motor speeds are given in the table on page 6.
  - max. permissible housing pressure  $p_{abs. max}$  \_\_\_\_\_ 6 bar
- The pressure in the housing must be the same as or greater than the external pressure on the shaft seal.

### Influence housing pressure to start of control

The housing pressure influences the start of control of the variable motor for the following controls: An increase of the housing pressure leads to an increase of the start of control for the HA control (only sizes 250...1000), HA.T and HD. For the DA control a lowering of the start of control is effected.

The setting on the test bench in the factory prior to delivery is  $p_{abs} = 1$  bar (sizes 250...1000) respectively  $p_{abs} = 2$  bar housing pressure (sizes 28...200).

## Technical Data

**Table of values** (theoretical values, without considering  $\eta_{mh}$  and  $\eta_{lv}$ ; values rounded)

Size			28	55	80	107	140	160	200	250	355	500	1000
Displacement <sup>1)</sup>	$V_{g\ max}$	cm <sup>3</sup>	28,1	54,8	80	107	140	160	200	250	355	500	1000
	$V_{g\ 0}$	cm <sup>3</sup>	0	0	0	0	0	0	0	0	0	0	0
Max. speed (at max. permitted flow)	$n_{max}$ at $V_{g\ max}$	rpm	5550	4450	3900	3550	3250	3100	2900	2500	2240	2000	1600
	$n_{max}$ at $V_g < V_{g,1}$	rpm	8750	7000	6150	5600	5150	4900	4600	3300	2950	2650	2100
	$V_{g,1}$	cm <sup>3</sup>	18	35	51	68	88	101	126	190	270	385	762
	$n_{max}$ at $V_{g\ 0}$	rpm	10450	8350	7350	6300	5750	5500	5100	3300	2950	2650	2100
Max. perm. flow	$q_{V\ max}$	L/min	156	244	312	380	455	469	580	625	795	1000	1600
Torque constants	$T_k$ at $V_{g\ max}$	Nm/bar	0,446	0,87	1,27	1,70	2,23	2,54	3,18	3,98	5,65	7,96	15,92
Max. torque	$T_{max}$ at $V_{g\ max}$ <sup>2)</sup>	Nm	179	349	509	681	891	1019	1273	1391	1978	2785	5571
Case volume		L	0,5	0,75	1,2	1,5	1,8	2,4	2,7	3,0	5,0	7,0	16,0
Moment of inertia about drive axis	$J$	kgm <sup>2</sup>	0,0014	0,0042	0,0080	0,0127	0,0207	0,0253	0,0353	0,061	0,102	0,178	0,550
Weight (approx.)	$m$	kg	16	26	34	47	60	64	80	90	170	210	430

<sup>1)</sup> The minimum and maximum displacement are infinitely adjustable, see ordering code page 3

(note for sizes 250...1000:  $V_{g\ min} = 0,2 \cdot V_{g\ max}$ ,  $V_{g\ max} = V_{g\ max}$ , when there is no indication in the order!)

<sup>2)</sup> sizes 28...200:  $\Delta p = 400$  bar; sizes 250...1000:  $\Delta p = 350$  bar

### Minimum inlet pressure at port A (B)

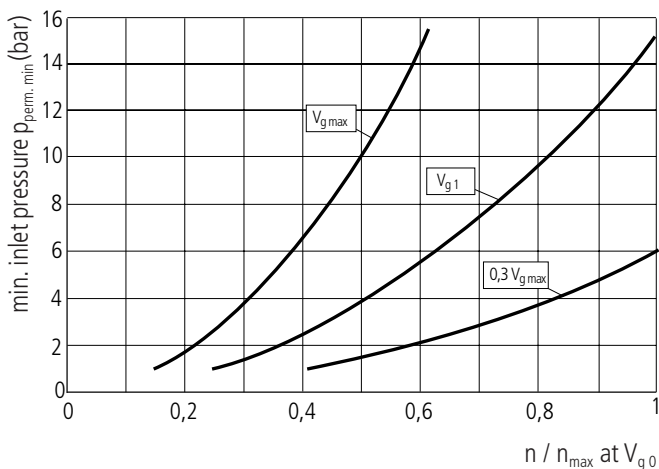

In order to avoid damage of the variable motor a minimum inlet pressure at the inlet zone must be assured. The minimum inlet pressure is related to the rotational speed and swivel angle (displacement) of the variable motor.

### Permissible displacement, speed related

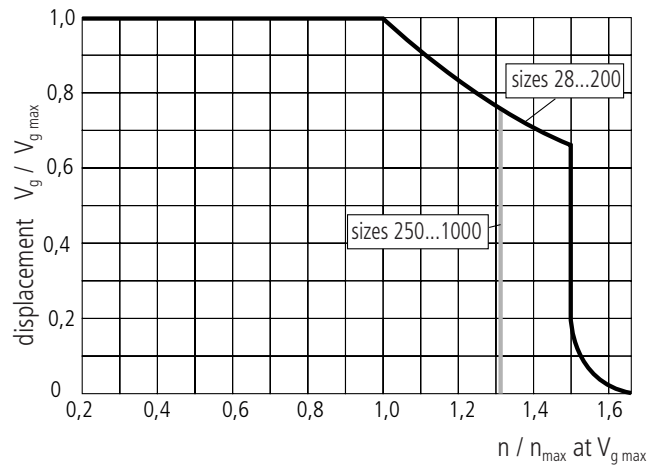

## Technical Data

### Output drive

Permissible axial and radial loading on drive shaft.

The values given are maximum values and not permissible for continuous operation.

Size		28	55	80	107	140	160	200	250	355	500	1000	
<i>a</i>	mm	12,5	15	17,5	20	22,5	22,5	25	41	52,5	52,5	67,5	
$F_{q\ max}$	N	5696	10440	13114	15278	17808	20320	22896	1200 <sup>1)</sup>	1500 <sup>1)</sup>	1900 <sup>1)</sup>	2600 <sup>1)</sup>	
$\pm F_{ax\ max}$	N	$+ F_{ax\ max}$	315	500	710	900	1030	1120	1250	4000	5000	6250	10000
		$- F_{ax\ max}$	315	500	710	900	1030	1120	1250	1200	1500	1900	2600
$\pm F_{ax\ perm.}/bar$	N/bar		4,6	7,5	9,6	11,3	13,3	15,1	17,0	<sup>2)</sup>	<sup>2)</sup>	<sup>2)</sup> <sup>2)</sup>	

<sup>1)</sup> Axial piston unit in stationary or in bypass operation, please contact us when appearing higher forces!

<sup>2)</sup> Please contact us!

### Code explanation

- a* = distance of  $F_q$  from shaft shoulder
- $F_{q\ max}$  = max. perm. radial force at distance *a* (at intermittent operation)
- $\pm F_{ax\ max}$  = max. perm. axial force when stationary or when axial piston unit is running at zero pressure
- $\pm F_{ax\ perm.}/bar$  = perm. axial force/bar operating pressure

The direction of the max. axial force must be noted by sizes 28...200

$- F_{ax\ max}$  = increased bearing life

$+ F_{ax\ max}$  = reduced bearing life (avoid if possible)

### Calculation of size

Flow  $q_v = \frac{V_g \cdot n}{1000 \cdot \eta_v}$  in L/min

Output speed  $n = \frac{q_v \cdot 1000 \cdot \eta_v}{V_g}$  in rpm

Output torque  $T = \frac{V_g \cdot \Delta p \cdot \eta_{mh}}{20 \cdot p}$  in Nm

$$= \frac{1,59 \cdot V_g \cdot \Delta p \cdot \eta_{mh}}{100}$$

or  $T = T_K \cdot \Delta p \cdot \eta_{mh}$  in Nm

Output power  $P = \frac{2 p \cdot T \cdot n}{60\ 000} = \frac{T \cdot n}{9549}$  in kW

$$= \frac{q_v \cdot \Delta p}{600} \cdot \eta_t$$

- $V_g$  = geometric displacement per rev. in cm<sup>3</sup>
- $T$  = torque in Nm
- $\Delta p$  = pressure differential in bar
- $n$  = speed in rpm
- $T_K$  = torque constants in Nm/bar
- $\eta_v$  = volumetric efficiency
- $\eta_{mh}$  = mech.-hyd. efficiency
- $\eta_t$  = overall efficiency

### Optimal force direction of $F_q$ (valid for sizes 28...200)

By means of appropriate force directions of  $F_q$  the bearing load caused by inside rotary group forces can be reduced. An optimal life expectation of the bearing can be reached.

#### Gear drive

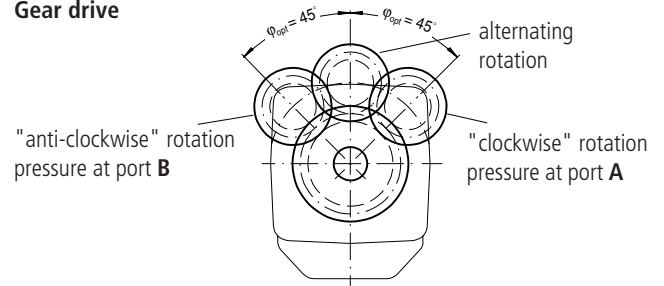

#### V-belt drive

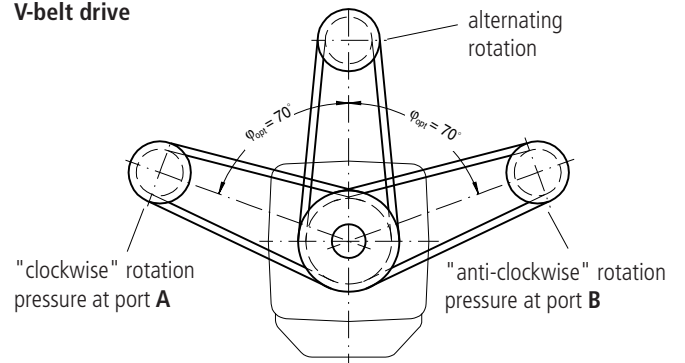

## DA Hydraulic Control, Speed Related

The A6VM variable motor with speed related hydraulic control is particularly suitable for use in hydrostatic transmissions in conjunction with variable pump A4VG with DA control.

The swivel angle of the hydraulic motor is controlled by means of the pilot pressure determined by the input speed of the A4VG variable pump and by the operating pressure.

An increase in the pump input speed and thus in the pilot pressure causes the motor, in relation to the existing operating pressure, to swivel towards a lower displacement volume (lower torque, higher speed).

If operating pressure should rise above the value set with the pressure control, the motor is then swivelled towards a higher displacement volume (higher torque, lower speed).

When designing a drive using DA control, note also the technical data of variable pump A4VG with DA control.

A computer program is available at Brueninghaus Hydromatik to help you with the design of your drive. Full details from our Mobile Sales Division on request.

### DA, DA1, DA4 Hydraulic control, speed related with hydraulic valve for travel direction

Through the control pressure  $X_1$  or  $X_2$  this valve is switched on/off dependent on the direction of rotation (travel direction).

direction of rotation	operation pressure in	control pressure in
clockwise	<b>A</b>	<b><math>X_1</math></b>
anti-clockwise	<b>B</b>	<b><math>X_2</math></b>

### DA2, DA3, DA5, DA6 Hydraulic control, speed related with el. $V_{g\max}$ -switching process

The electrical valve is operated by the pressure spring or switch solenoid (a) dependent on the rotational direction (travel direction).

Through connection of the electric current at the switch solenoid (b) override of the control is possible and the motor is switched to max. swivel angle (high torque, low speed) (el.  $V_{g\max}$ -switching process).

DA2, DA5 switching solenoid a, b 12 V DC; 1,6 A (min.)

DA3, DA6 switching solenoid a, b 24 V DC; 0,8 A (min.)

### Hydraulic control, speed related DA1, DA4

Sizes 28...200

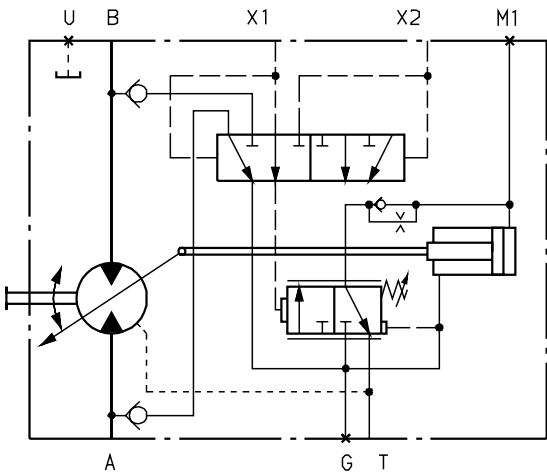

direction of rotation	operating pressure in	switching solenoid a
clockwise	A	energised
anti-clockwise	B	de-energised

### Hydraulic control, speed related DA

Sizes 250...1000

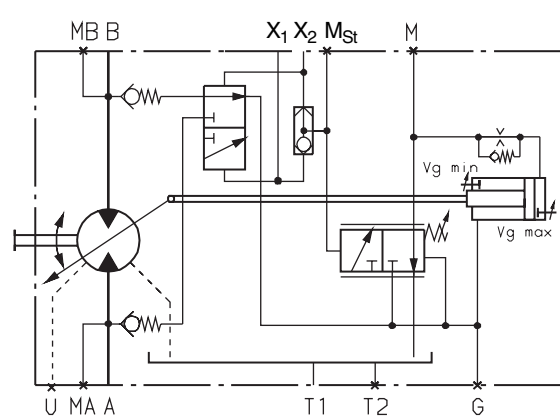

### Hydraulic control, speed related DA2, DA3, DA5, DA6

Sizes 28...200

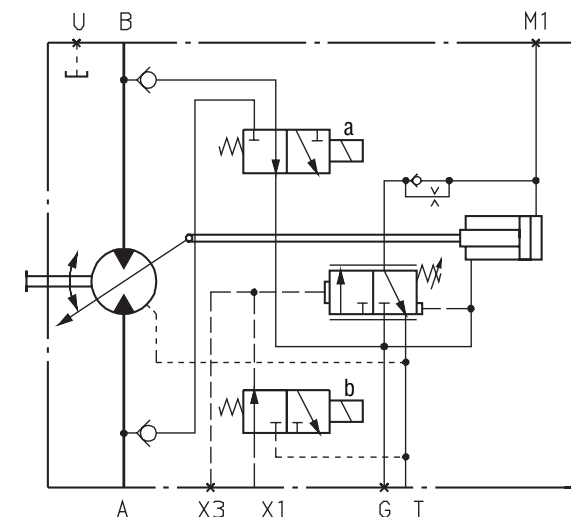



### Unit Dimensions DA

Before finalising your design, please request a certified drawing.

#### Unit dimensions DA1, DA4

Sizes 28...200

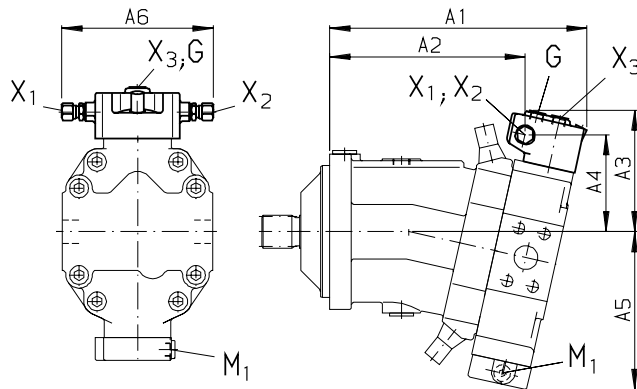

Size	A1	A2	A3	A4	A5	A6	ports X <sub>1</sub> , X <sub>2</sub>
28	216	152	120	93	136	160	locking GE-8LM
55	242	179	122	94	151	160	locking GE-8LM
80	271	207	127	100	167	160	locking GE-8LM
107	291	216	134	107	175	174	locking GE-8LM
140	322	247	141	115	195	174	locking GE-8LM
160	329	254	141	115	197	174	locking GE-8LM
200	346	271	146	119	209	174	locking GE-8LM

#### Unit dimensions DA2, DA3, DA5, DA6

Sizes 28...200

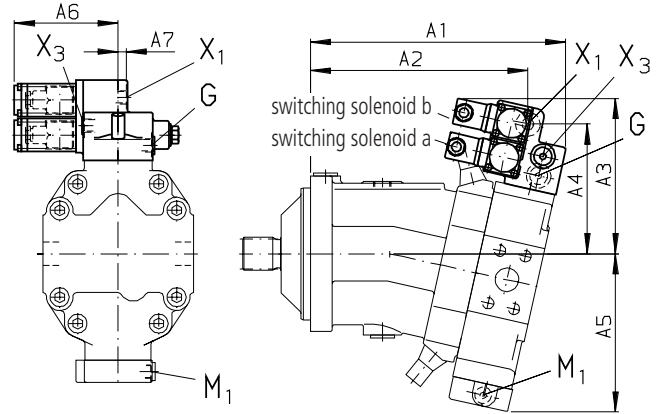

Size	A1	A2	A3	A4	A5	A6	A7	port X <sub>1</sub>
28	218	175	158	130	136	110	8,5	M14x1,5
55	245	202	159	132	151	110	8,5	M14x1,5
80	271	230	162	138	167	110	8,5	M14x1,5
107	292	239	173	146	175	112	8,5	M14x1,5
140	323	270	181	154	195	112	8,5	M14x1,5
160	330	277	181	153	197	112	8,5	M14x1,5
200	347	294	185	158	209	112	8,5	M14x1,5

X<sub>1</sub>: pilot pressure port

#### Unit dimensions DA

Size 250

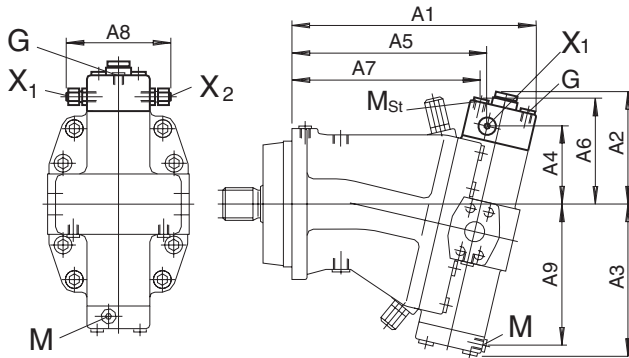

Size	A1	A2	A3	A4	A5	A6	A7	A8	A9
250	385	188 (max)	248	126	307	161	296	159	227

ports X<sub>1</sub>, X<sub>2</sub>: locking B0-GEV 8L/M14x1,5-WD

#### Unit dimensions DA

Sizes 355, 500

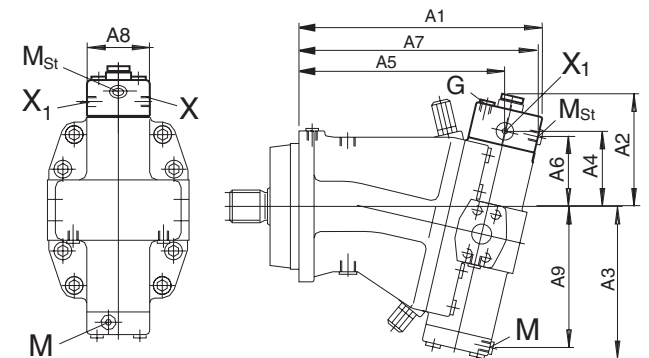

Size	A1	A2	A3	A4	A5	A6	A7	A8	A9
355	432	203 (max)	279	140	327	123	422	108	257
500	490	215 (max)	306	151	423	137	481	123	284

ports X<sub>1</sub>, X<sub>2</sub>: M14x1,5

## HA Automatic Control, High Pressure Related

With the automatic, high pressure related control, setting of the displacement is effected automatically as a function of the operating pressure.

This control device measures the operating pressure at A or B internally (no pilot line required) and swivels from  $V_{g, \min}$  with increasing working pressure to  $V_{g, \max}$  once the pressure setting of the control is reached.

Standard version HA1, HA2:

Start of control at  $V_{g, \min}$  (min. torque, max. perm. speed)

End of control at  $V_{g, \max}$  (max. torque, min. speed)

### HA1: Virtually no pressure increase

An working pressure increase of  $\Delta p \leq 10$  bar results in an increase of the displacement from 0  $\text{cm}^3$  to  $V_{g, \max}$  (sizes 28...200) respectively from  $0,2 V_{g, \max}$  to  $V_{g, \max}$  (sizes 250...1000).

Start of control, setting range

sizes 28...200 \_\_\_\_\_ 80 – 350 bar

sizes 250...1000 \_\_\_\_\_ 80 – 340 bar

When ordering please state required start of control in clear text, e.g.: start of control at 300 bar

HA1

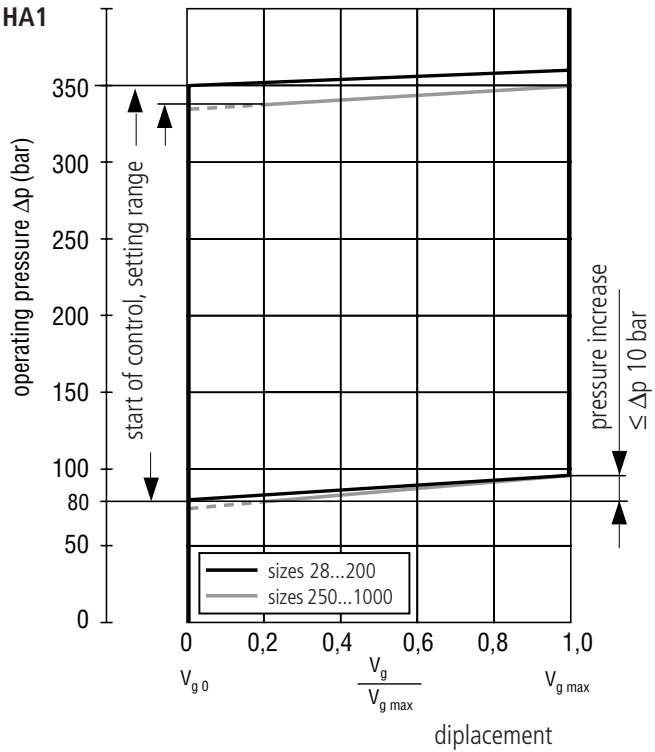

### Automatic control, high pressure related HA1

Sizes 28...200

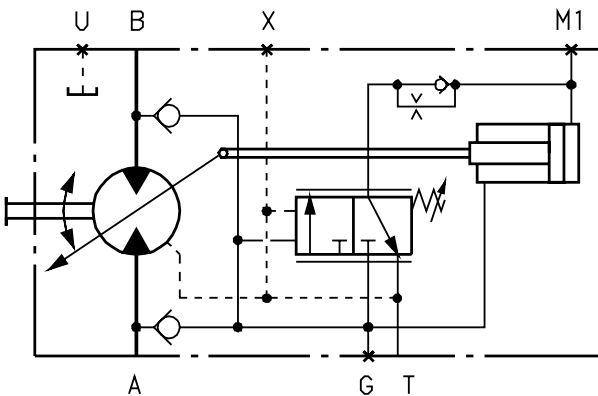

### Automatic control, high pressure related HA1

Sizes 250...1000

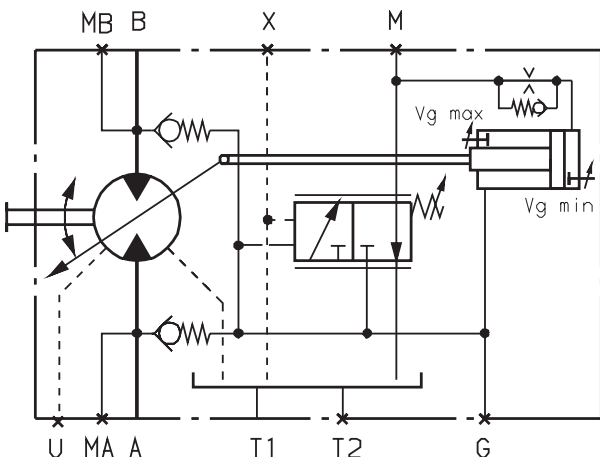

### Note:

- Because of safety reasons hoist winch drives are not allowed with control devices with start of control at  $V_{g, \min}$  (standard design with HA)!

## HA Automatic Control, High Pressure Related

### HA2: Pressure increase $\Delta p = 100$ bar

An working pressure increase from  $\Delta p = 100$  bar results in an increase of the displacement from  $0 \text{ cm}^3$  to  $V_{g \text{ max}}$  (sizes 28...200) respectively from  $0,2 V_{g \text{ max}}$  to  $V_{g \text{ max}}$  (sizes 250...1000).

Start of control, setting range

sizes 28...200 \_\_\_\_\_ 80 – 350 bar

sizes 250...10000 \_\_\_\_\_ 80 – 250 bar

When ordering please state required start of control in clear text, e.g.: start of control at 200 bar

### Automatic control, high pressure related HA2

Sizes 28...200

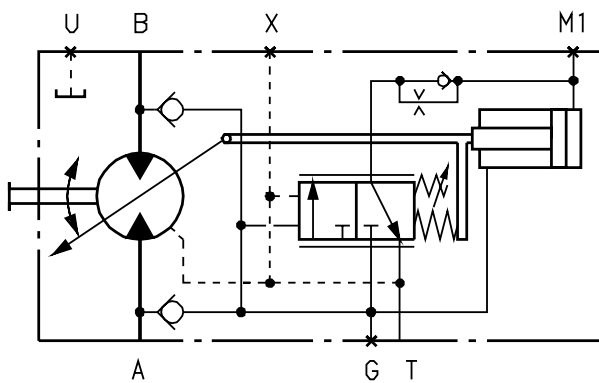

### Automatic control, high pressure related HA2

Sizes 250...1000

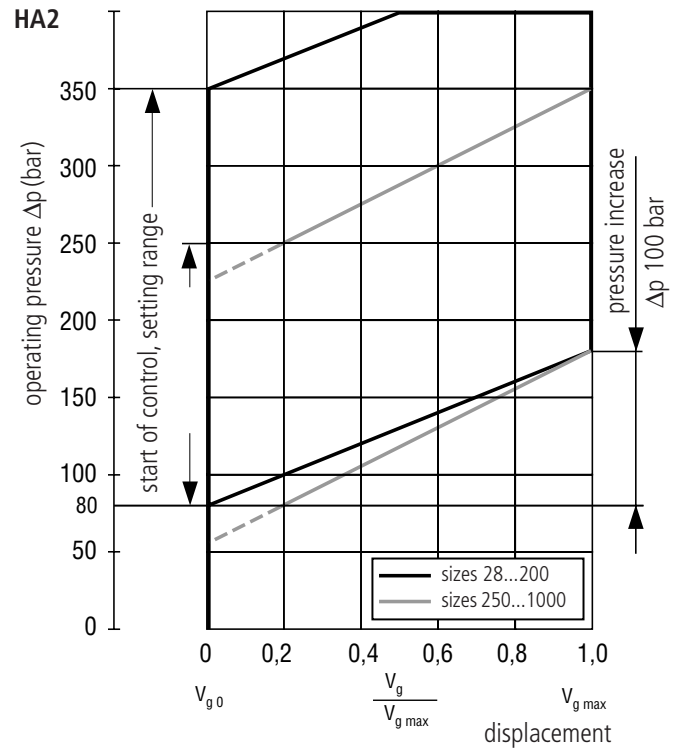
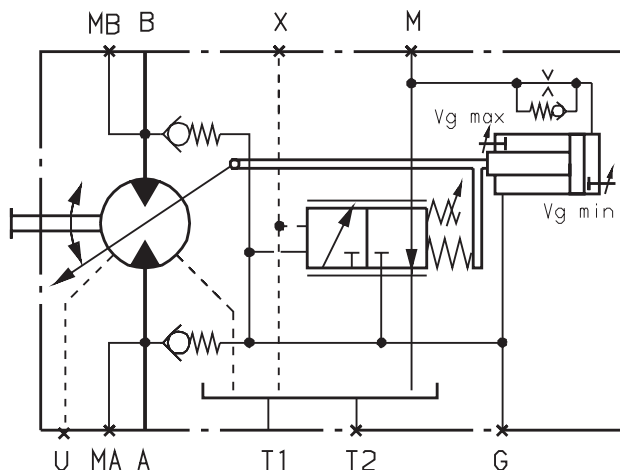

# HA Automatic Control, High Pressure Related (Override)

## U1, U2 Electrical override of pressure setting

On version HA1 the high pressure related control can be overridden by means of an electrical signal to a switching solenoid.

The override causes the motor to swivel to its maximum angle.

Switching solenoid de-energised  $\hat{=}$  no override

Switching solenoid energised  $\hat{=}$  motor set to  $V_{g\ max}$

**U1** switching solenoid 12 V DC, 1,6 A (min.)

**U2** switching solenoid 24 V DC, 0,8 A (min.)

Start of control adjustable between 80 and 300 bar (state required setting in clear text when ordering)

### HA1U1, HA1U2

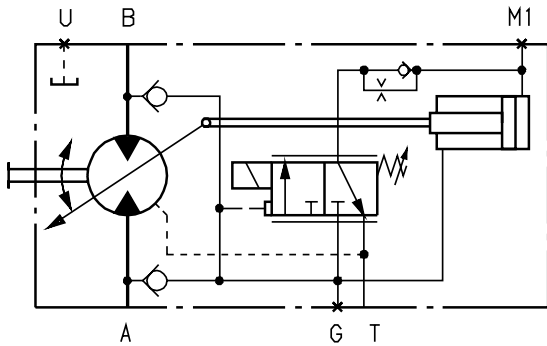

### HA2U1, HA2U2

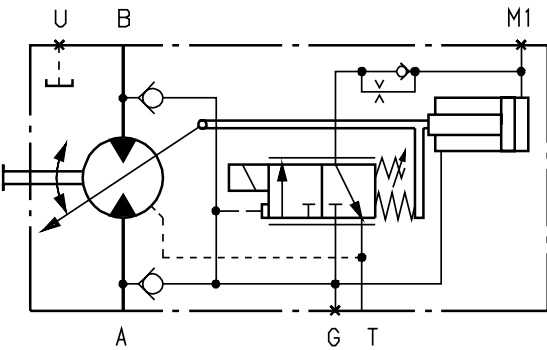

## T Hydraulic override of pressure setting

For the HA control the start of control can be influenced by applying a pilot pressure at port X.

1 bar control pressure lowers the start of control by 17 bar (sizes 28...200) or 8 bar (sizes 250...1000).

Example (sizes 28...200):

Start of control setting	300 bar	300 bar
Pilot pressure at X	0 bar	10 bar
Start of control	300 bar	130 bar

If the override is only required to set the max displacement (motor swivel to  $V_{g\ max}$ ), a pilot pressure of up to 100 bar max. is permissible. (Circuit diagram and unit dimensions see control HA1, HA2, port X open, at sizes 250...1000 no connection from X to T)

## R1, R2 Electrical override of pressure setting, with electrical valve for travel direction

On the HA control version the high pressure related control can be overridden by a electrical signal to a switching solenoid b. The override swivels the variable to a max. swivel angle.

switching solenoid b de-energised  $\hat{=}$  no override

switching solenoid b energised  $\hat{=}$  motor set to  $V_{g\ max}$

The travel directional valve assures that the preselected pressure side of the variable motor always controls the swivel angle even at a change of the high pressure side (for instance travel drive down hill). The swivel of the variable motor to a bigger displacement can be avoided.

In relation of a change of direction (travel direction) the travel directional valve is actuated through the pressure spring or the switch solenoid a.

direction of rotation	operating pressure in	switching solenoid a
clockwise	<b>A</b>	<b>de-energised</b>
anti-clockwise	<b>B</b>	<b>energised</b>

**R1** switching solenoid a, b 12 V DC 1,6 A (min.)

**R2** switching solenoid a, b 24 V DC 0,8 A (min.)

### HA1R1, HA1R2

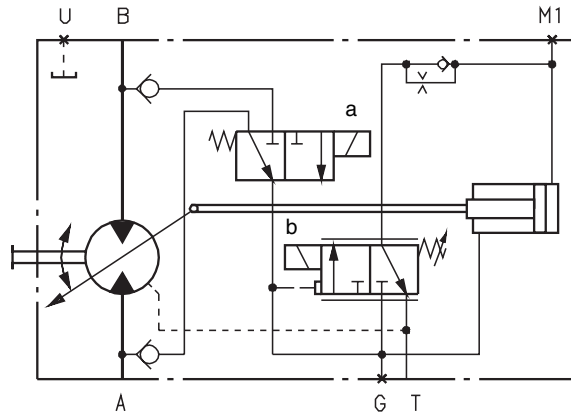

### HA2R1, HA2R2

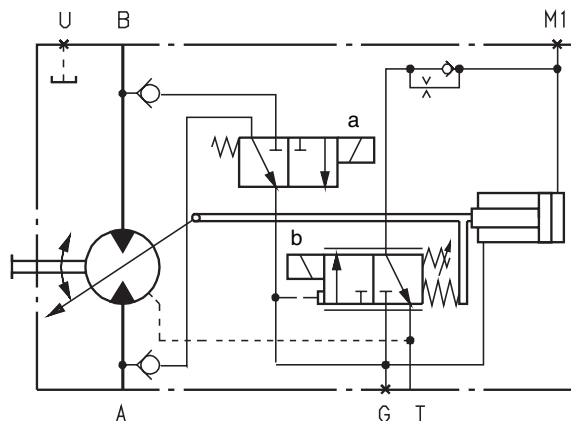

### Unit Dimensions HA

Before finalising your design, please request a certified drawing.

#### Unit dimensions HA1, HA2, HA1T, HA2T Sizes 28...200

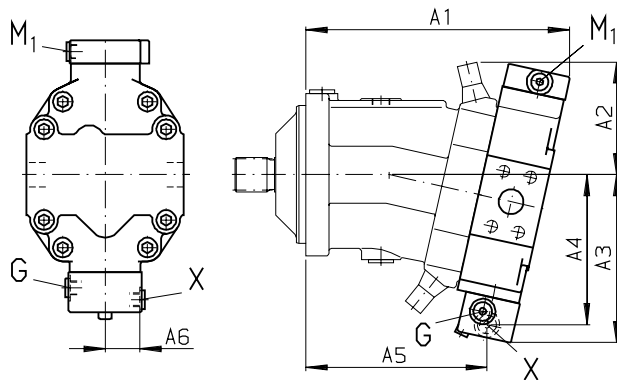

Size	A1	A2	A3	A4	A5	A6
28	209	97	151	133	134	34,5
55	237	104	159	142	159	33,4
80	268	114	171	152	183	34,5
107	290	122	183	164	199	40,5
140	316	132	198	178	225	40,5
160	323	137	200	181	232	40,5
200	339	143	209	190	245	40,5

port X: M 14x1,5 (plugged, open for design HA.T)

#### Unit dimensions HA1, HA2, HA1T, HA2T Sizes 250...1000

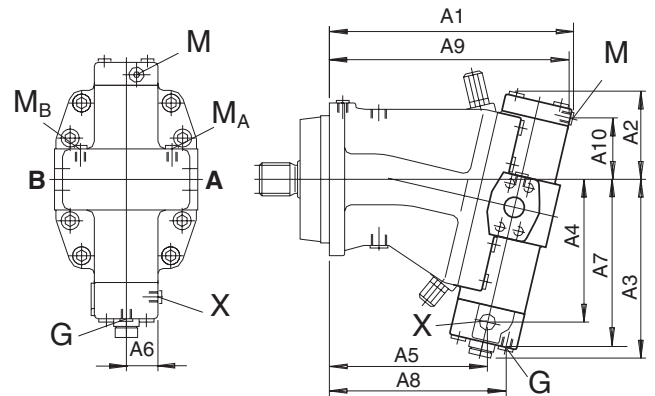

Size	A1	A2	A3	A4	A5	A6	A7	A8	A9	A10
250	384	161	275	210	248	48,5	248	278	377	116
355	432	181	300	234	279	54	275	315	425	132
500	489	196	325	258	322	61,5	300	359	483	144
1000										

port X: M 14x1,5 (plugged, open for design HA.T)

#### Unit dimensions HA.U1, HA.U2 Sizes 28...200

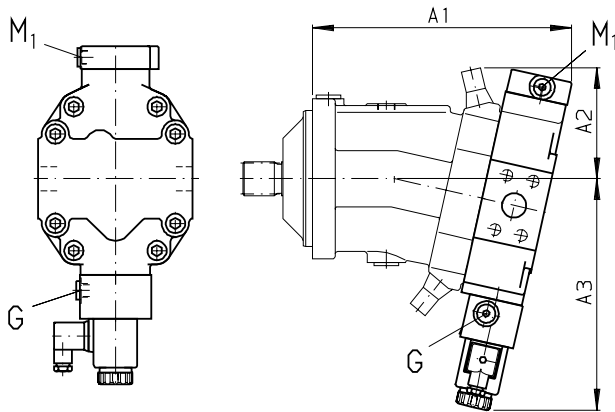

Size	A1	A2	A3
28	209	97	216
55	237	104	224
80	268	114	238
107	282	122	249
140	316	132	263
160	323	137	266
200	339	143	275

#### Unit dimensions HA.R1, HA.R2 Sizes 28...200

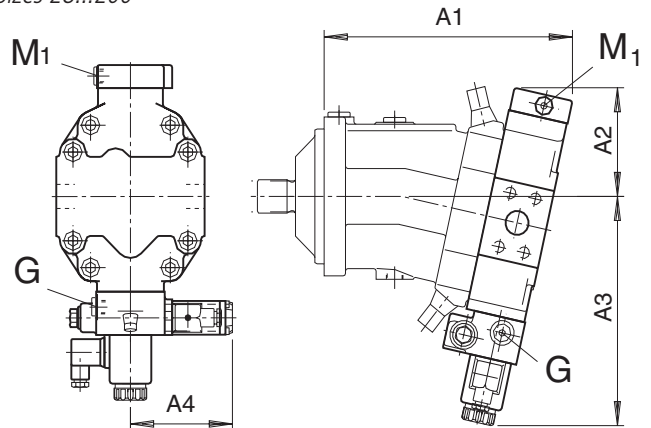

Size	A1	A2	A3	A4
28	209	97	216	110
55	237	104	224	110
80	268	114	238	110
107	282	122	249	112
140	316	132	263	112
160	323	137	266	112
200	339	143	275	112

## HD Hydraulic Control, Pilot Pressure Related

The pilot pressure related hydraulic control allows infinite variation of the motor displacement in relation to a pilot pressure signal. The control function is proportional to the pilot pressure applied at port X.

### HD1: Pilot pressure increase $\Delta p_s = 10$ bar

A pilot pressure increase of 10 bar at port X results in a decrease of the displacement from  $V_{g \max}$  to 0 cm<sup>3</sup> (sizes 28...200) respectively from  $V_{g \max}$  to 0,2  $V_{g \max}$  (sizes 250...1000).

Start of control, setting range \_\_\_\_\_ 2 – 20 bar

Standard setting: start of control at 3 bar (end of control at 13 bar)

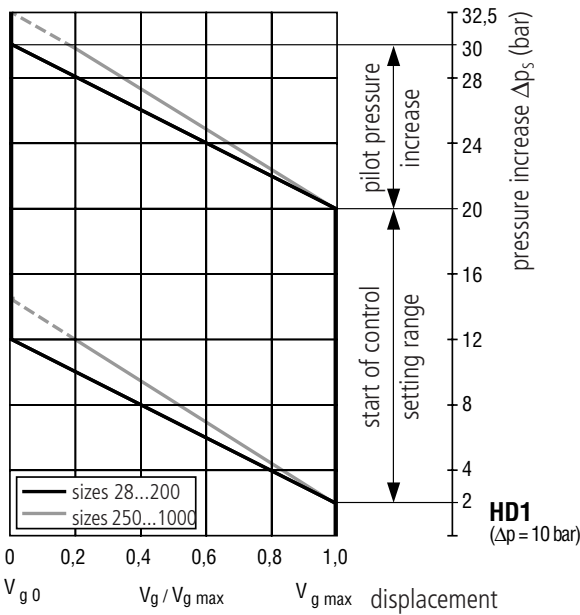

### HD2: Pilot pressure increase $\Delta p_s = 25$ bar

A pilot pressure increase of 25 bar at port X results in a decrease of the displacement from  $V_{g \max}$  auf 0 cm<sup>3</sup> (sizes 28...200) respectively from  $V_{g \max}$  to 0,2  $V_{g \max}$  (sizes 250...1000).

Start of control, setting range \_\_\_\_\_ 5 – 50 bar

Standard setting: start of control at 10 bar (end of control at 35 bar)

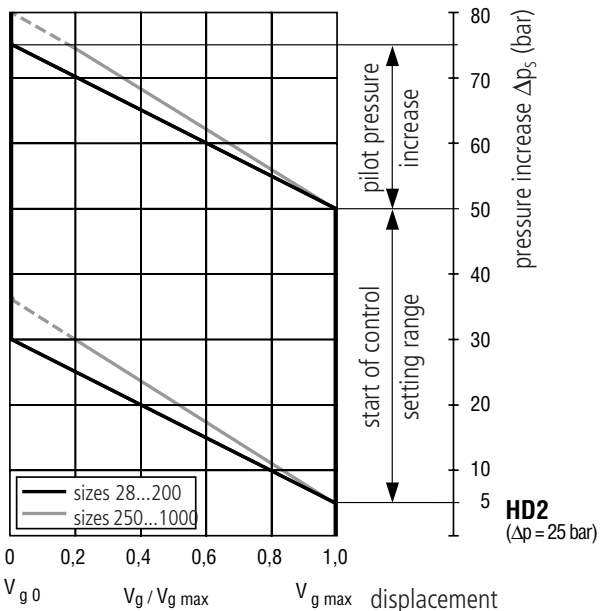

Standard version:

- start of control at  $V_{g \max}$  (max. torque, min. speed)
- end of control at  $V_{g \min}$  (min. torque, max. perm. speed)

### HD3: Pilot pressure increase $\Delta p_s = 35$ bar

A pilot pressure increase of 35 bar at port X results in a decrease of the displacement from  $V_{g \max}$  to 0,2  $V_{g \max}$  (sizes 250...1000).

Start of control, setting range \_\_\_\_\_ 7 – 50 bar

Standard setting: start of control at 10 bar (end of control at 45 bar)

Note:

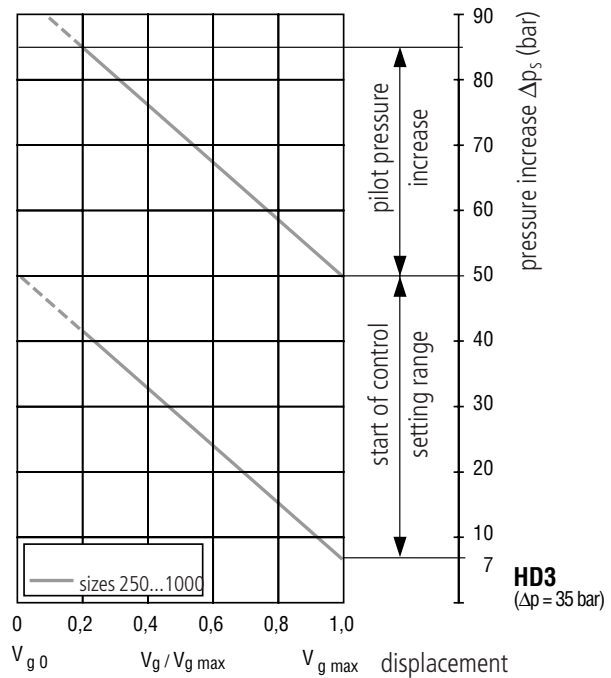

- The start of control and the HD curve is influenced by the housing pressure. An increase of the housing pressure causes an increase of the start of control and thus a parallel displacement of the curve characteristic (see page 5).

- The required control oil is taken from the high pressure side; for this, a minimum operating pressure of 15 bar is necessary. If it is necessary to operate the control at an operating pressure of <15 bar, a boost pressure of min. 15 bar must be applied at port G via an external check valve (max. perm. pilot pressure 100 bar).

- Due to internal leakage a leakage flow of approx. 0,3 L/min occurs at port X. In order to avoid the influence of the curve characteristic the leakage flow must be led out through the control module into the tank.

- When ordering please state required start of control in clear text, e.g.: start of control at 10 bar

Unit dimensions control HD, see pages 23...33

# HD Hydraulic Control, Pilot Pressure Related

## Hydraulic control, pilot pressure related HD1, HD2, HD3

Sizes 28...200

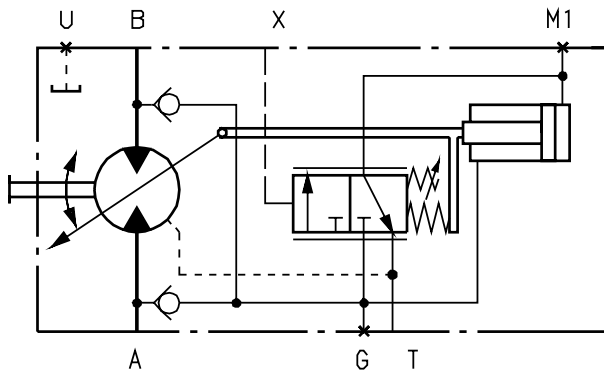

Sizes 250...1000

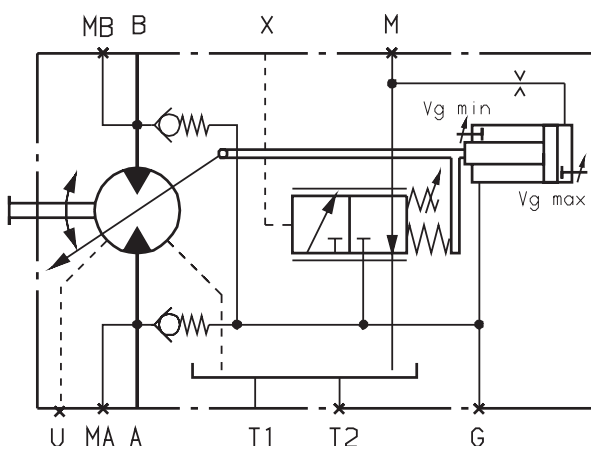

## Variation: Constant pressure control (HD.D)

The constant pressure control is superimposed on the HD function. Should system pressure rise as a result of the load torque or reduction of the motor swivel angle, when the setting of the constant pressure control is reached the motor is swivelled out to a higher angle.

As a result of the increased displacement and consequent pressure reduction, the control deviation is eliminated. By increasing the displacement the motor produces a higher torque at a constant pressure.

Setting range of constant pressure control valve:

sizes 28...200 \_\_\_\_\_ 80 - 400 bar

sizes 250...1000 \_\_\_\_\_ 80 - 350 bar

Sizes 28...200 (HD.D)

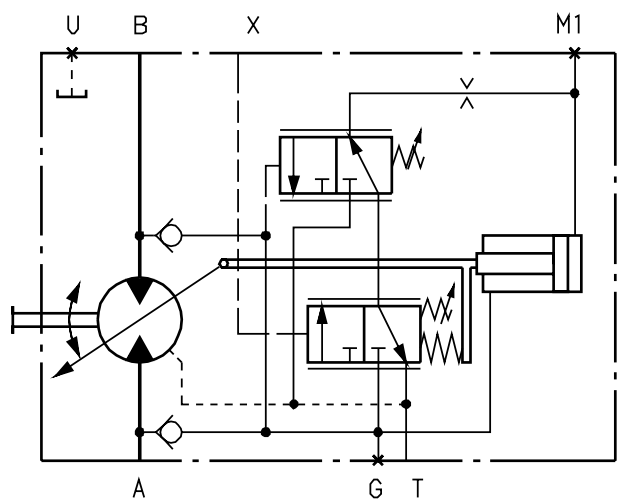

Sizes 250...1000 (HD.D)

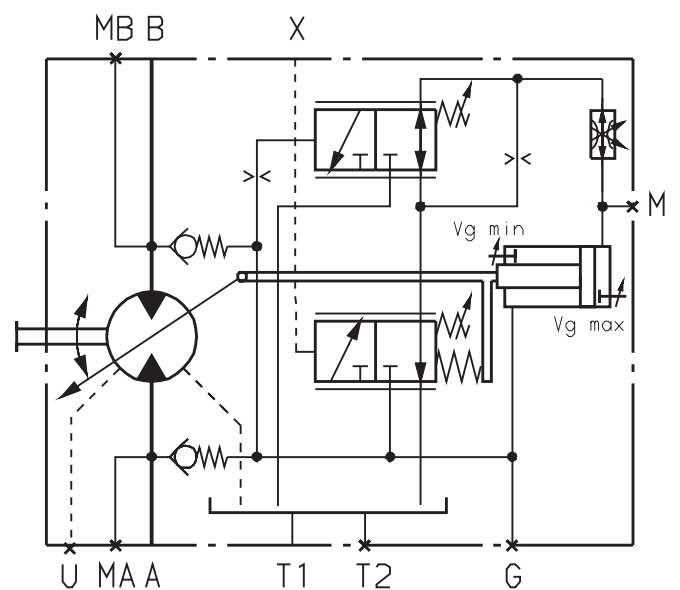

## HD Hydraulic Control, Pilot Pressure Related

### Variation: Remote constant pressure control (HD.G)

The remote pressure control controls the motor when reaching the set pressure command signal continuously until it reaches the max. displacement  $V_{g \max}$ . A pressure relief valve (not supplied), which is separate to the motor, is responsible for the control of the internal pressure cut-off valve. As long as the pressure command signal has not been obtained, the valve is, in addition to the spring force, pressurised from both sides, and is held closed. The pressure command signal is between 80 bar and 350 bar. On reaching the pressure command signal at the separate pressure relief valve, this opens, whereby the pressure on the spring side is allowed to flow to tank. The internal pilot valve operates and the motor swivels to maximum displacement  $V_{g \max}$ . The pressure difference at the pilot valve is set as standard to 25 bar. We recommend the following as a separate pressure relief valve:

DBD 6 (hydraulic) to RE 25402

The max. line length should not exceed 2 m.

Sizes 250... 1000 (HD.G)

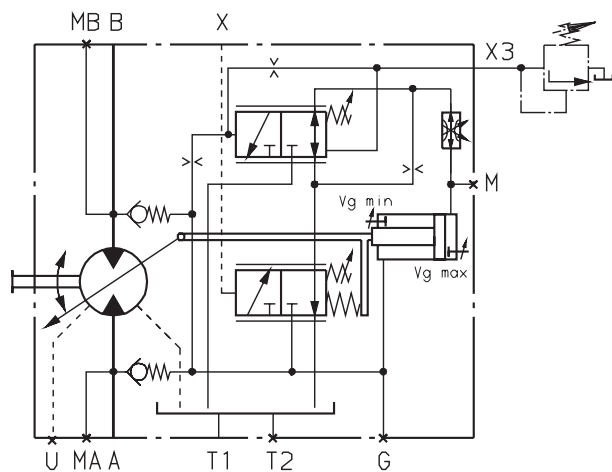

### Variation: pressure control with 2nd pressure setting (HD.E)

Through input of an external control pressure at port G2 the setting of the pressure regulator can be overridden and a 2nd pressure setting can be realised. The pressure signal at port G2 must be between 20 and 50 bar (when ordering please state the 2nd pressure setting in clear text).

Sizes 28..200 (HD.E)

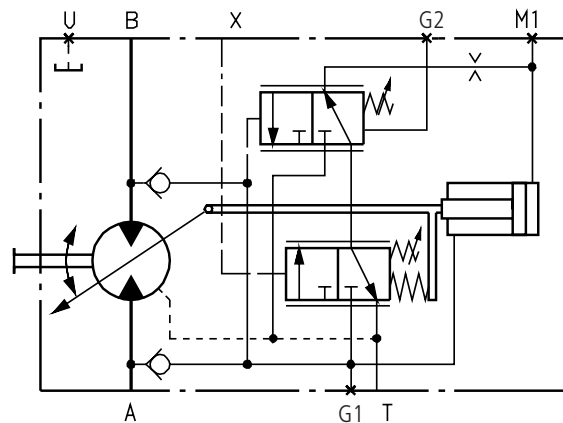



### Unit Dimensions HD

Before finalising your design, please request a certified drawing.

#### Unit dimensions HD.D

Sizes 28...200

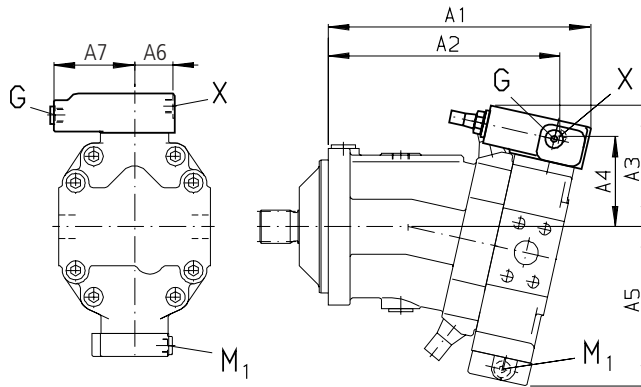

Size	A1	A2	A3	A4	A5	A6	A7
28	214	189	119	87	136	35,5	88,5
55	241	216	120	89	151	35,5	88,5
80	269	244	126	95	167	35,5	88,5
107	291	258	133	101	175	40,5	88,5
140	323	290	141	108	195	40,5	88,5
160	329	297	141	108	197	40,5	88,5
200	346	313	145	112	209	40,5	88,5

#### Unit dimensions HD.E

Sizes 28...200

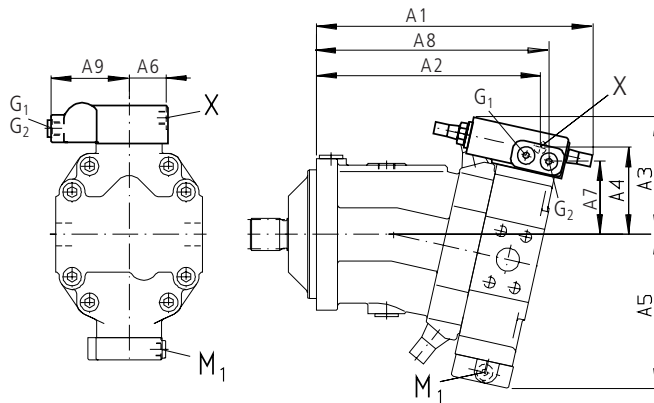

Size	A1	A2	A3	A4	A5	A6	A7	A8	A9
28									
55	272	216	126	89	151	35,5	76	232	88,5
80	301	244	129	95	167	35,5	79	259	88,5
107	311	258	136	101	175	40,5	86	270	88,5
140									
160	349	297	144	108	197	40,5	93	309	88,5
200	369	313	147	112	209	40,5	98	324	88,5

G1: port for synchronous control of a number of units and for remote control pressure M 14x1,5 (plugged)

G2: port for 2nd pressure setting M 14x1,5 (plugged)

#### Unit dimensions HD.D, HD.G

Sizes 250...1000

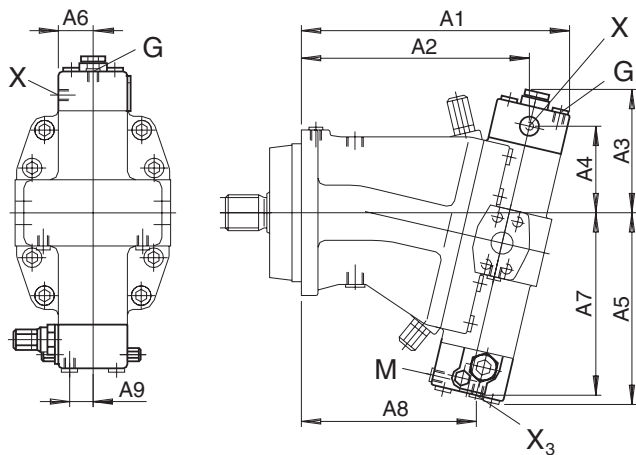

Size	A1	A2	A3	A4	A5	A6	A7	A8	A9
250	385	327	188	123	272	48,5	256	276	35
355	432	366	203	137	288	54	271	287	33
500	490	417	215	148	306	61,5	287	314	23
1000	618	537	274	189	388	70	373	420	51

pilot pressure port X<sub>3</sub>: M 14x1,5 (open at HD.G, plugged at HD.D)

## HZ Hydraulic Two-Position Control

Before finalising your design, please request a certified drawing.

The hydraulic two-position control allows the displacement to be set to  $V_{g\ min}$  or  $V_{g\ max}$  by application or non-application of pilot pressure to port X.

without control pressure  $\cong$  motor set to  $V_{g\ max}$   
 with control pressure (> 10 bar)  $\cong$  motor set to  $V_{g\ min}$

The required control oil is taken from the high pressure side; for this, a minimum operating pressure of 15 bar is necessary. If it is necessary to operate the control at an operating pressure of <15 bar, a boost pressure of min. 15 bar must be applied at port G via an external check valve.

### Hydraulic two-position control HZ1

Sizes 28, 140, 160, 200

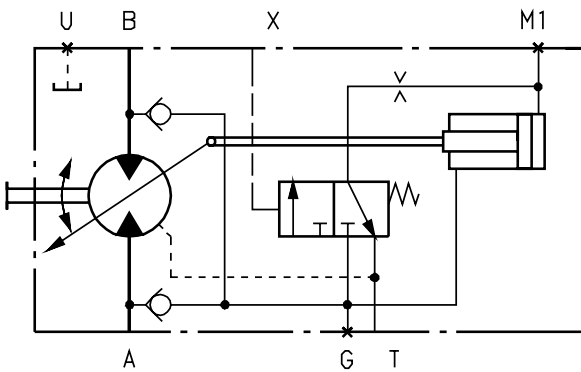

### Hydraulic two-position control HZ3

Sizes 55, 80, 107

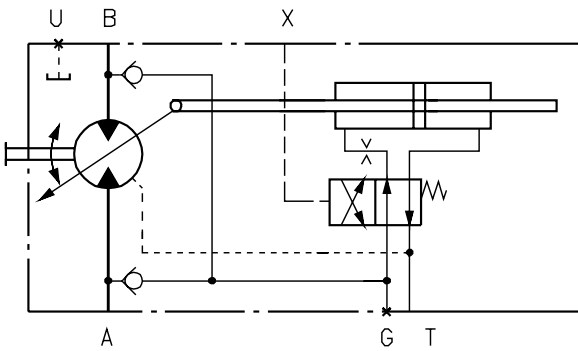

### Hydraulic two-position control HZ

Sizes 250...1000

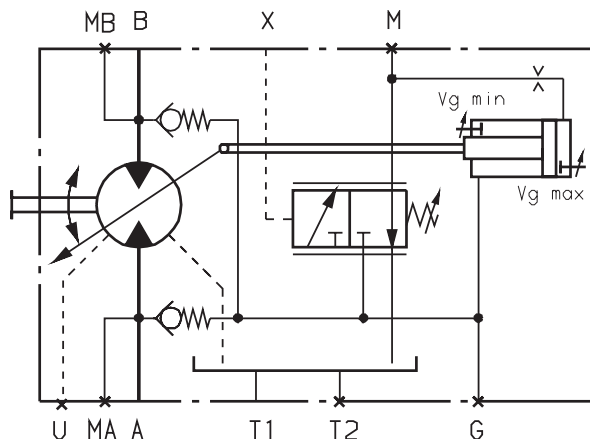

### Unit dimensions HZ3 \*)

Sizes 55, 80, 107

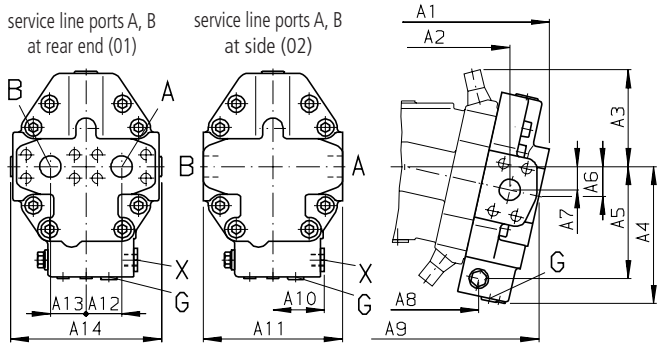

Size	A1	A2	A3	A4	A5	A6	A7	A8	A9
55	227	183	100	146	117	31	24	151	215
80	255	208	114	161	132	35	27	172	242
107	270	220	122	173	143	38	30	182	256

Size	A10	A11	A12	A13	A14	ports A, B	port X
55	61	152	37,5	37,5	160	SAE 3/4"	M14x1,5
80	61	164	42	42	172	SAE 1	M14x1,5
107	61	180	42	42	188	SAE 1	M14x1,5

\*) unit dimensions of control HZ (sizes 250...1000) and HZ1 (sizes 28, 140, 160, 200) see pages 22-32

Standard version:

- start of control at  $V_{g\ max}$  (max. torque, min. speed)
- end of control at  $V_{g\ min}$  (min. torque, max. perm. speed)

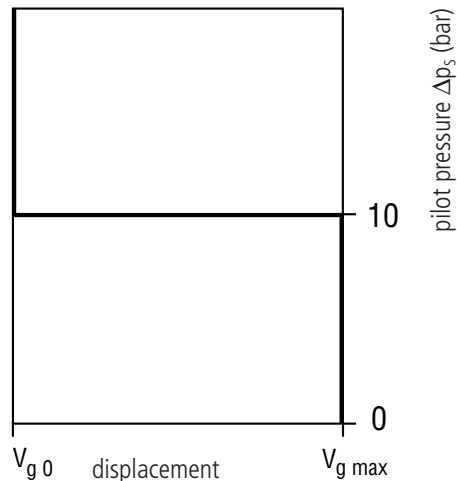

## EZ Electrical Two-Position Control with Switching Solenoid

The electrical two-position control with switching solenoid allows the displacement to be set to  $V_{g,max}$  or  $V_{g,min}$  by energising or de-energising the solenoid.

Solenoid de-energised  $\cong$  motor set to  $V_{g,max}$   
 Solenoid energised  $\cong$  motor set to  $V_{g,min}$

EZ1, EZ3 switching solenoid 12 V DC, 26W (EZ1) 30W (EZ3)

EZ2, EZ4 switching solenoid 24 V DC, 26W (EZ2) 30W (EZ4)

The required control oil is taken from the high pressure side; for this, a minimum operating pressure of 15 bar is necessary. If it is necessary to operate the control at an operating pressure of <15 bar, a boost pressure of min. 15 bar must be applied at port G via an external check valve.

### Electrical two-position control EZ1, EZ2

Sizes 28, 140, 160, 200

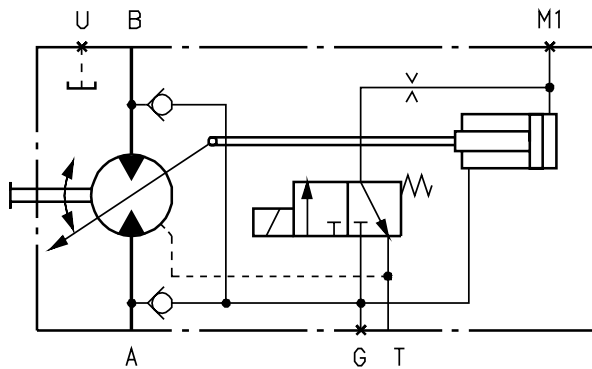

### Electrical two-position control EZ3, EZ4

Sizes 55, 80, 107

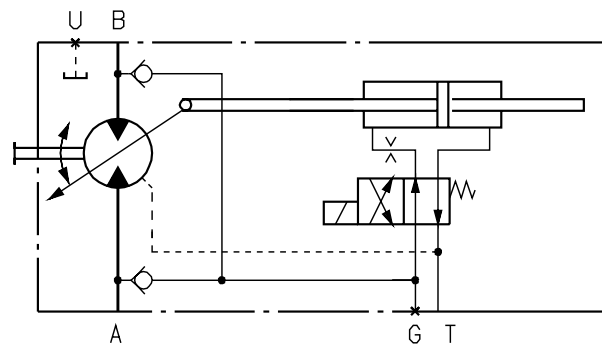

### Electrical two-position control EZ1, EZ2

Sizes 250...1000

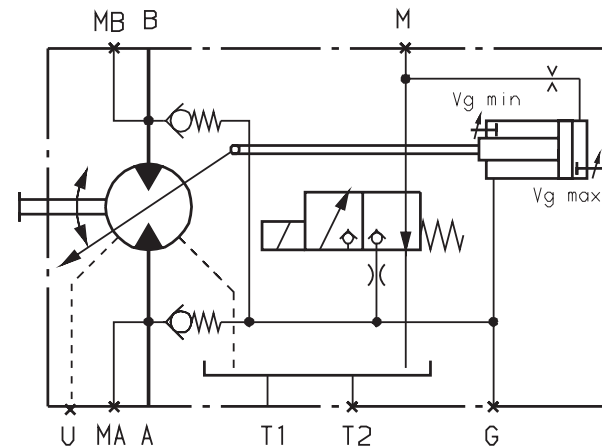

### Unit dimensions EZ1, EZ2

Sizes 28, 140, 160, 200

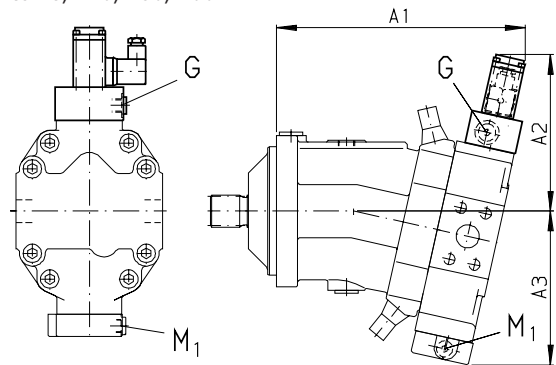

Size A1 A2 A3

28 216 163 136

140 321 184 195

160 328 184 197

200 344 188 209

### Unit dimensions EZ3, EZ4

Sizes 55, 80, 107

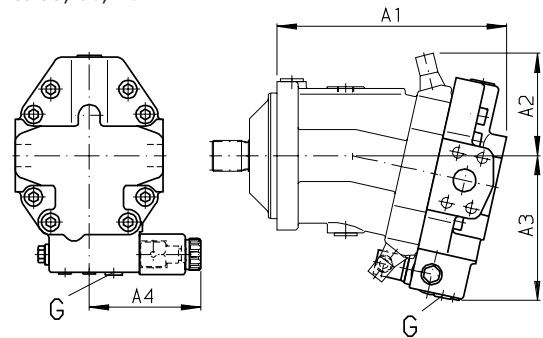

Size A1 A2 A3 A4

55 227 100 146 124

80 255 114 161 124

107 270 122 173 124

(additional dimensions of the port plate see page 18, HZ3-control)

### Unit dimensions EZ1, EZ2

Sizes 250...1000

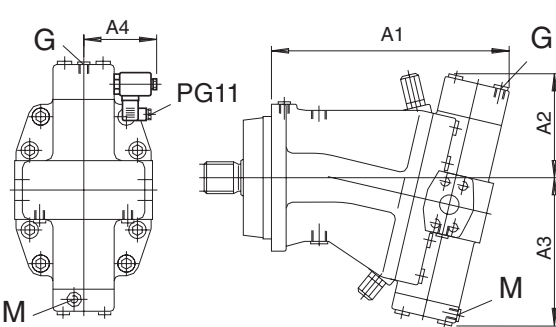

Size A1 A2 A3 A4

250 385 171 248 125

355 432 182 279 128,5

500 490 197 306 135,5

1000

## EP Electrical Control, with Proportional Solenoid

The electrical control with proportional solenoid or proportional valve (sizes 250...1000) allows infinite variation of the motor displacement in relation to an electrical signal.

The control function is proportional to the electrical control current applied.

For the sizes 250...1000 an external pressure of  $p_{min} = 30$  bar is necessary ( $p_{max} = 100$  bar) at port P for the control oil supply.

Sizes 28...200		control current	start of control	end of control
	control voltage (DC)		( $V_{g\ max}$ )	( $V_{g\ min} = 0$ )
EP1	12 V	400 mA	400 mA	1200 mA
EP2	24 V	200 mA	200 mA	600 mA

Sizes 250...1000		control current	start of control	end of control
	control voltage (DC)		( $V_{g\ max}$ )	( $V_{g\ min} = 0,2 V_{g\ max}$ )
EP1	12 V	900 mA	900 mA	1400 mA
EP2	24 V	450 mA	450 mA	700 mA

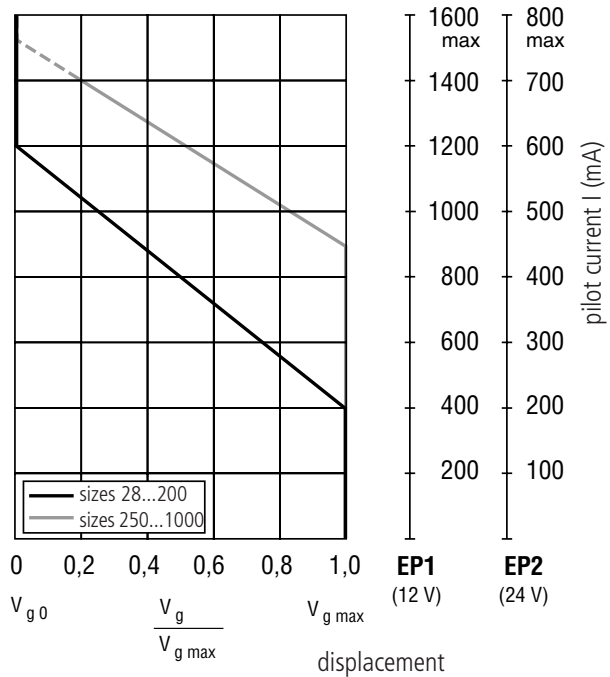

Standard version:

- start of control at  $V_{g\ max}$  (max. torque, min. speed)
- end of control at  $V_{g\ min}$  (min. torque, max. perm. speed)

The required control oil is taken from the high pressure side; for this, a minimum operating pressure of 15 bar is necessary. If it is necessary to operate the control at an operating pressure of <15 bar, a boost pressure of min. 15 bar must be applied at port G via an external check valve (max. perm. pilot pressure: 100 bar).

Adjustment of the control speed or limiting of the displacement (limiting of swivel) range by electrical means is possible using the following control devices:

- Proportional amplifier PV \_\_\_\_\_ see RE 95023
- Chopper amplifier CV \_\_\_\_\_ see RE 95029
- Electrical amplifier 2014/15 \_\_\_\_\_ see RE 95027
- Electrical amplifier VT 2000, series 40 \_\_\_\_\_ see RE 29908

### Electrical control with proportional solenoid EP1, EP2

Sizes 28...200

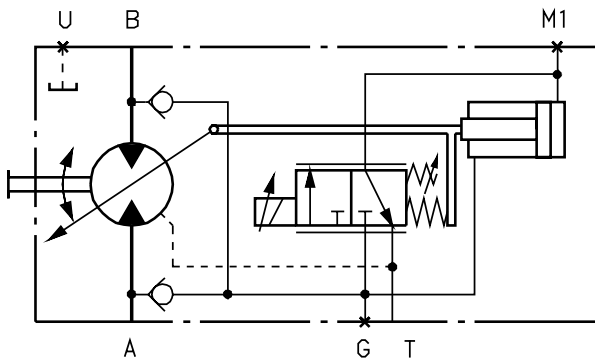

### Electrical control with proportional solenoid EP1, EP2

Sizes 250...1000

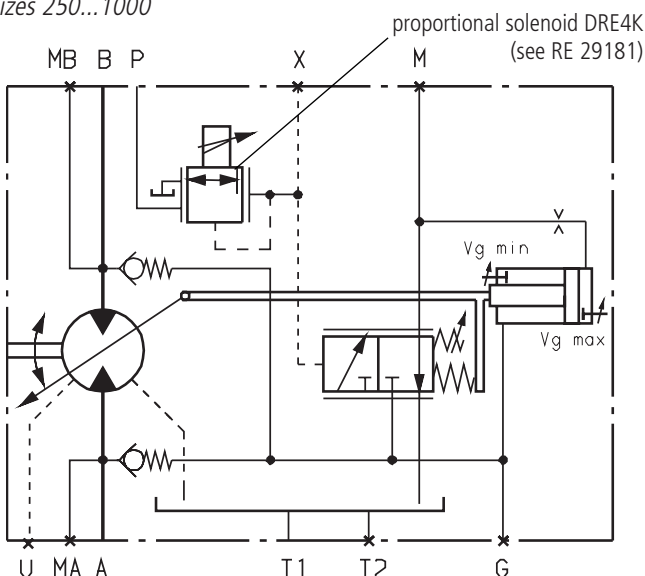

## EP Electrical Control, with Proportional Solenoid

### Variation: Direct constant pressure control (EP.D)

The constant pressure control is superimposed on the EP function. Should system pressure rise as a result of the load torque or reduction of the motor swivel angle, when the setting of the constant pressure control is reached the motor is swivelled out to a higher angle.

As a result of the increased displacement and consequent pressure reduction, the control deviation is eliminated. By increasing the displacement the motor produces a higher torque at a constant pressure.

Setting range of constant pressure control valve:

Sizes 28...200 \_\_\_\_\_ 80 - 400 bar

Sizes 250...1000 \_\_\_\_\_ 80 - 350 bar

Sizes 28...200 (EP.D)

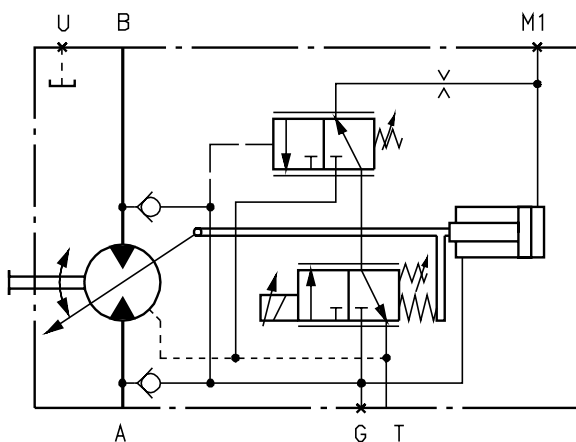

Sizes 250...1000 (EP.D)

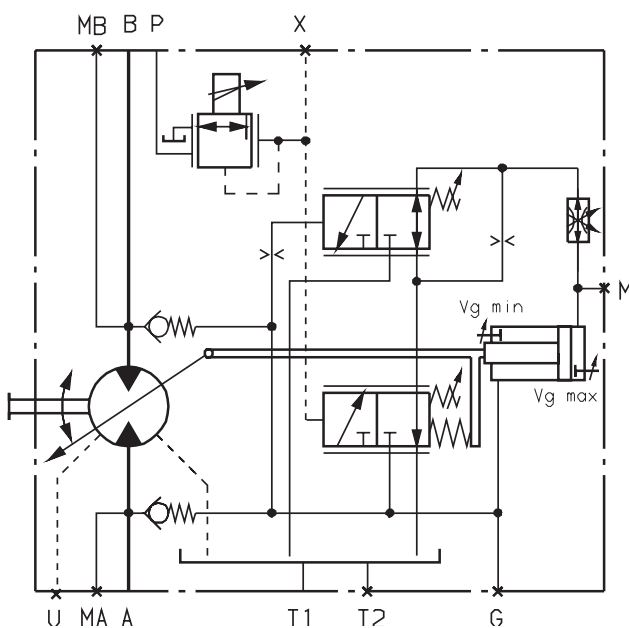

### Variation: pressure control with 2nd pressure setting (EP.E)

Through input of an external control pressure at port G2 the setting of the pressure regulator can be overridden and a 2nd pressure setting can be realised. The pressure signal at port G2 must be between 20 and 50 bar (when ordering please state the 2nd pressure setting in clear text).

Sizes 28...200 (EP.E)

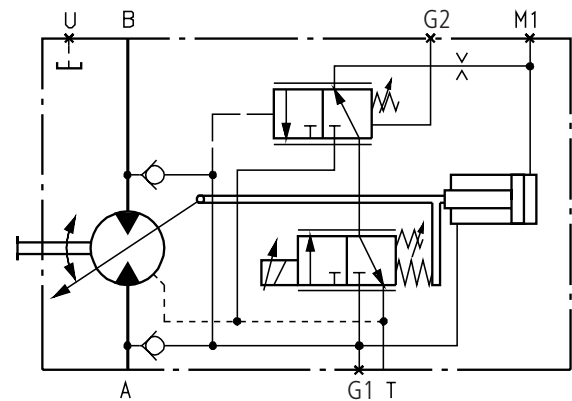

### Variation: Remote constant pressure control (EP.G)

The remote pressure control controls the motor when reaching the set pressure command signal continuously until it reaches the max. displacement  $V_{g,max}$ . A pressure relief valve (not supplied), which is separate to the motor, is responsible for the control of the internal pressure cut-off valve.

As long as the pressure command signal has not been obtained, the valve is, in addition to the spring force, pressurised from both sides, and is held closed. The pressure command signal is between 80 bar and 350 bar. On reaching the pressure command signal at the separate pressure relief valve, this opens, whereby the pressure on the spring side is allowed to flow to tank. The internal pilot valve operates and the motor swivels to maximum displacement  $V_{g,max}$ . The pressure difference at the pilot valve is set as standard to 25 bar. We recommend the following as a separate pressure relief valve:

DBD 6 (hydraulic) to RE 25402

The max. line length should not exceed 2 m.

Sizes 250...1000 (EP.G)

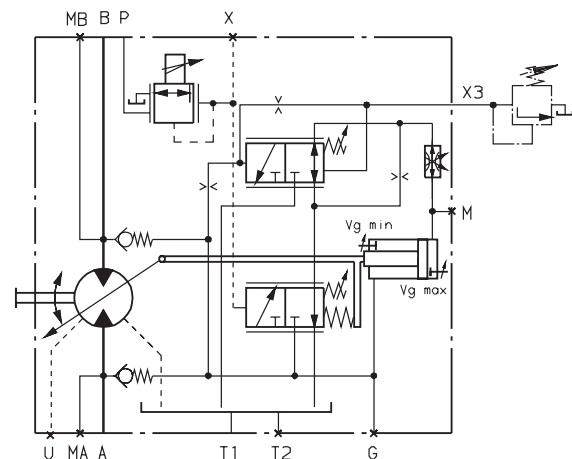

## Unit Dimensions EP

Before finalising your design, please request a certified drawing.

### Unit dimensions EP1, EP2

Sizes 28...200

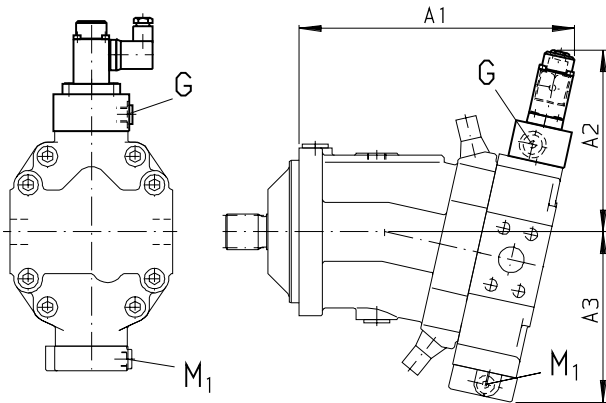

### Unit dimensions EP.D

Sizes 28...200

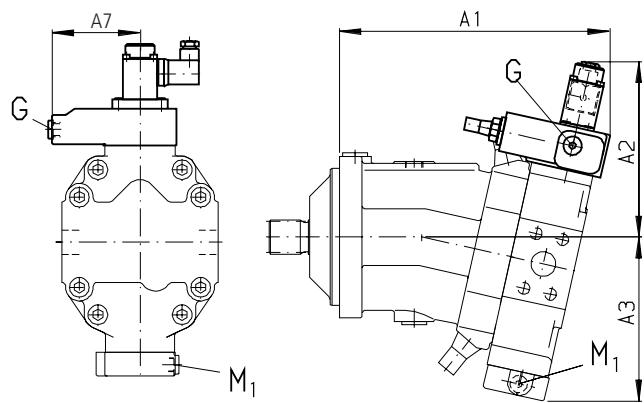

### Unit dimensions EP.E

Sizes 28...200

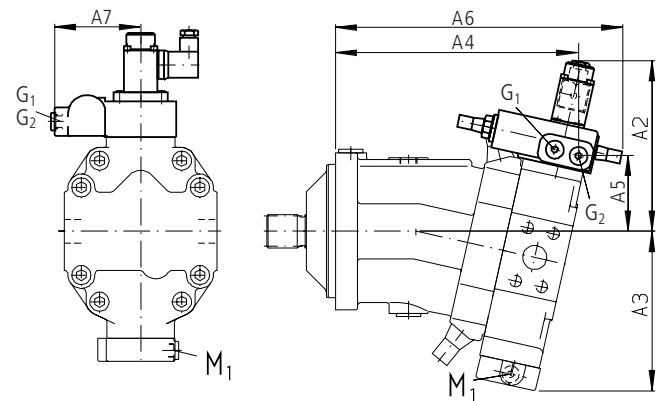

Size	A1	A2	A3	A4	A5	A6	A7
28	214	166	136				88,5
55	241	167	151	231	73	271	88,5
80	269	173	167	259	79	299	88,5
107	290	179	175				88,5
140	322	187	195				88,5
160	329	187	197	309	93	351	88,5
200	345	191	209	325	97	368	88,5

G1: port for synchronous control of a number of units and for remote control pressure M 14x1,5 (plugged)  
 G2: port for 2nd pressure setting M 14x1,5 (plugged)

### Unit dimensions EP1, EP2

Sizes 250...1000

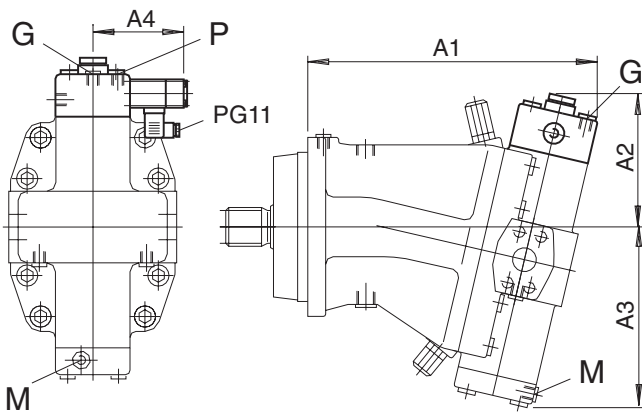

### Unit dimensions EP.D, EP.G

Sizes 250...1000

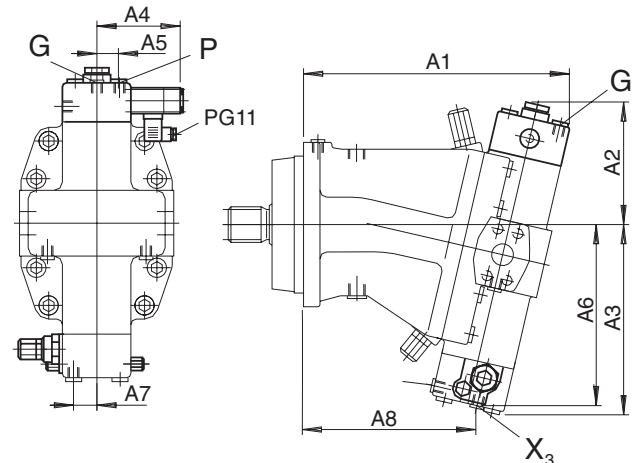

Size	A1	A2	A3	A4
250	385	188	272	124
355	432	203	288	125
500	490	215	306	132
1000				

pilot pressure port P: M 14x1,5

Size	A1	A2	A3	A4	A5	A6	A7	A8
250	385	188	272	124	36	256	35	267
355	432	203	288	125	36	271	33	287
500	490	215	306	132	43	287	32	314
1000								

pilot pressure port P: M 14x1,5

pilot pressure port X<sub>3</sub>: M 14x1,5 (open at EP.G, plugged at EP.D)







### Unit Dimensions Size 80

Before finalising your design, please request a certified drawing.

#### Hydraulic control, pilot pressure related HD1, HD2

Service line ports A/B on (opposite) sides (02)

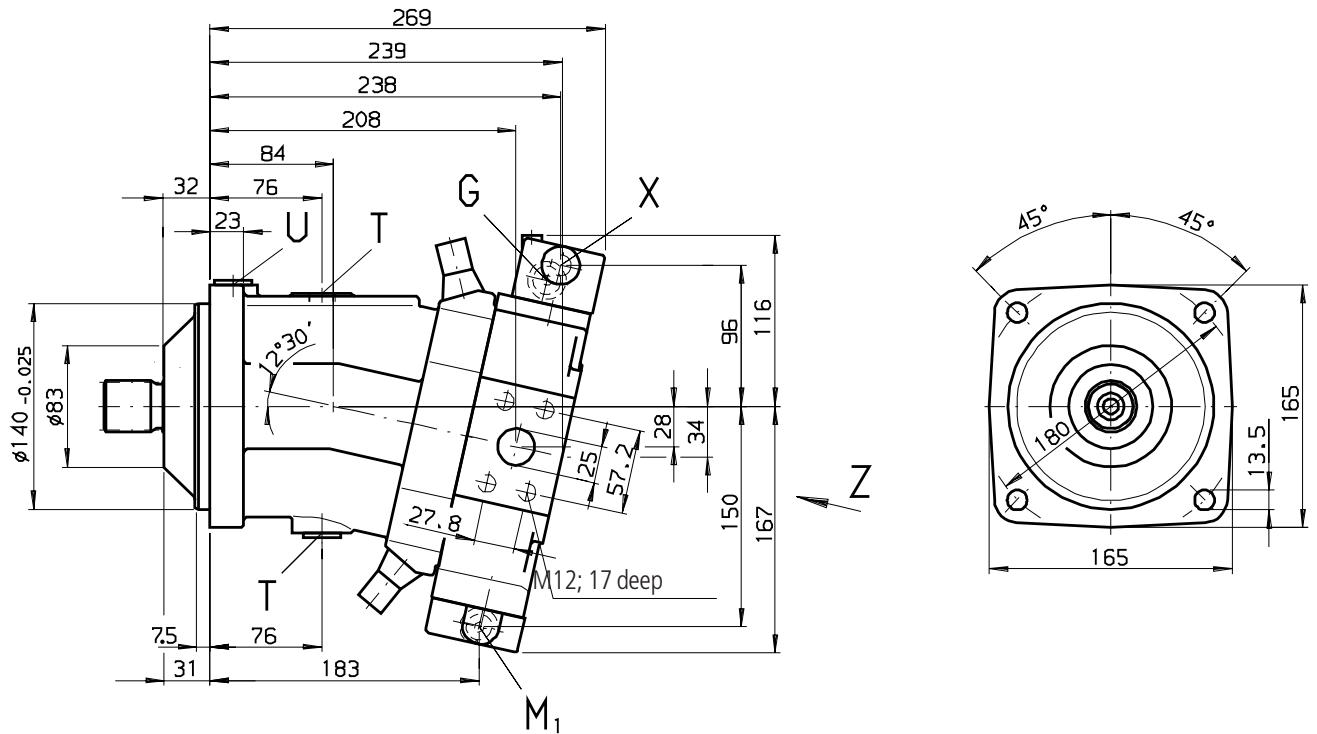

View Z

Service line ports A/B on (opposite) sides (02)

Service line ports A/B at rear end (01)

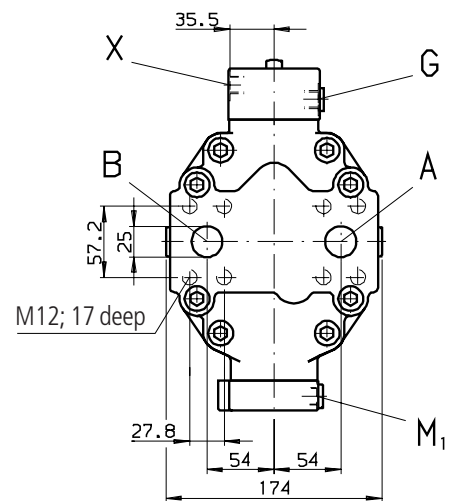
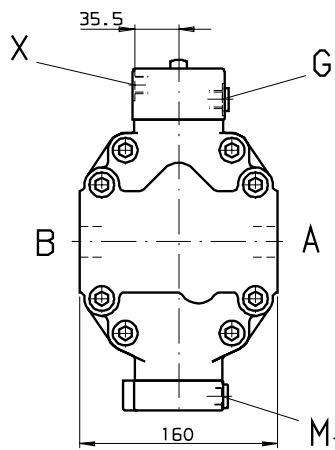

#### Shaft ends

##### A

Splined shaft  
W 40x2x30x18x9g  
DIN 5480

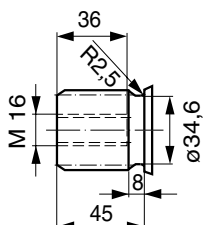

##### Z

Splined shaft  
W 35x2x30x16x9g  
DIN 5480

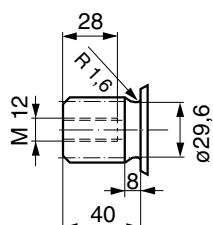

#### Connections

A; B	Service line ports 420 bar (6000 psi) high pressure series	SAE 1"
G	Port for synchronous control of a number of units and for remote control pressure (plugged)	M 14x1,5
X	Pilot pressure port	M 14x1,5
T	Case drain port	M 18x1,5
U	Flushing port (plugged)	M 18x1,5
M <sub>1</sub>	Test port for control pressure (plugged)	M 14x1,5

### Unit Dimensions Size 107

Before finalising your design, please request a certified drawing.

#### Hydraulic control, pilot pressure related HD1, HD2

Service line ports A/B on (opposite) sides (02)

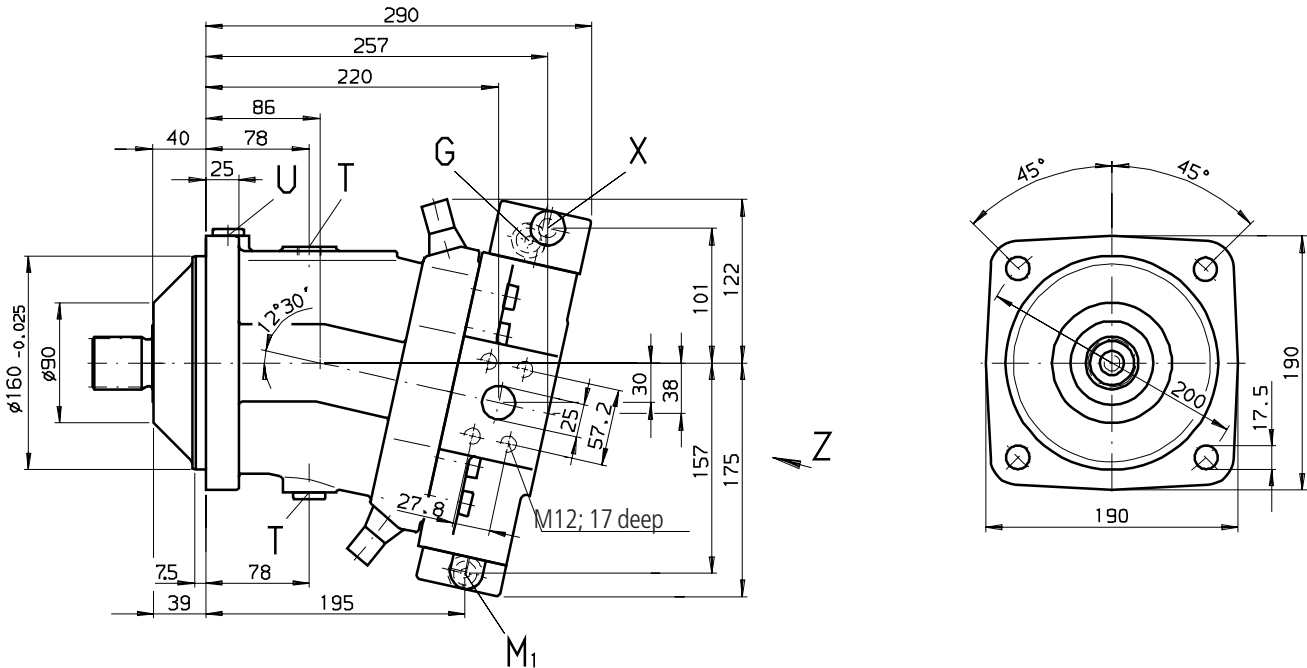

View Z

Service line ports A/B on (opposite) sides (02)

Service line ports A/B at rear end (01)

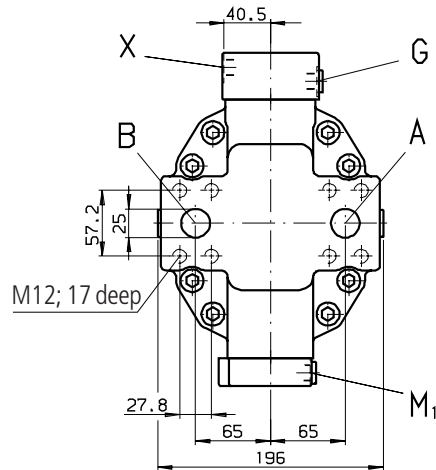
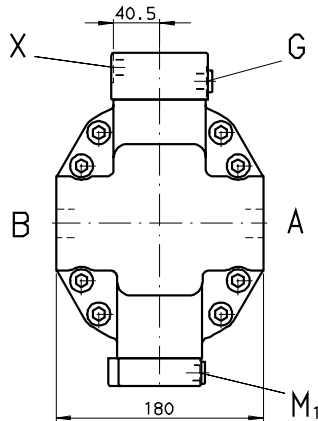

#### Shaft ends

**A**

Splined shaft  
W 45x2x30x21x9g  
DIN 5480

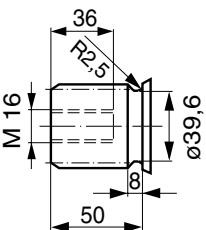

**Z**

Splined shaft,  
W 40x2x30x18x9g  
DIN 5480

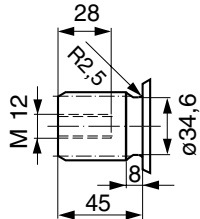

#### Connections

A; B	Service line ports 420 bar (6000 psi) high pressure series	SAE 1"
G	Port for synchronous control of a number of units and for remote control pressure (plugged)	M 14x1,5
X	Pilot pressure port	M 14x1,5
T	Case drain port	M 18x1,5
U	Flushing port (plugged)	M 18x1,5
M <sub>1</sub>	Test port for control pressure (plugged)	M 14x1,5

## Unit Dimensions Size 140

Before finalising your design, please request a certified drawing.

### Hydraulic control, pilot pressure related HD1, HD2 Hydraulic two-position control HZ1

Service line ports A/B on (opposite) sides **(02)**

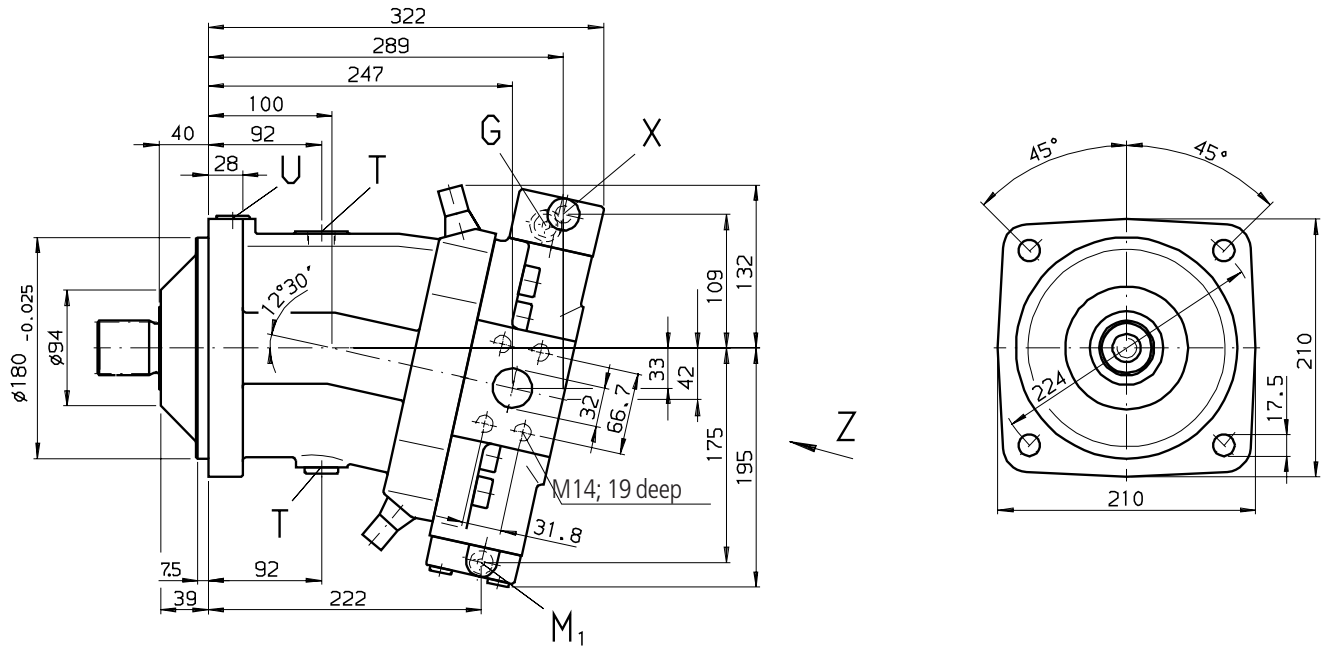

View Z

Service line ports A/B on (opposite) sides **(02)**

Service line ports A/B at rear end **(01)**

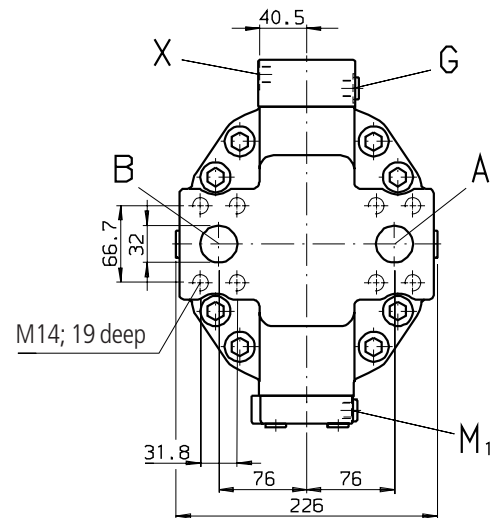
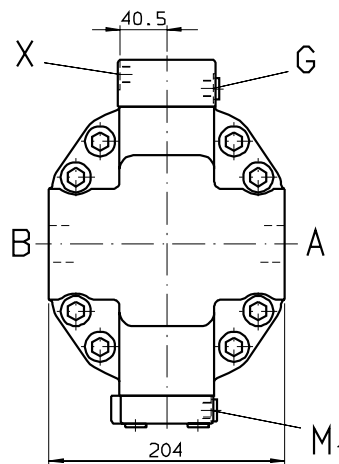

### Shaft ends

#### Z

Splined shaft,  
W 45x2x30x21x9g  
DIN 5480

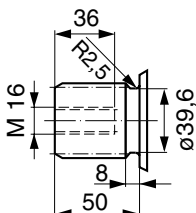

### Connections

A; B	Service line ports 420 bar (6000 psi) high pressure series	SAE 1 1/4"
G	Port for synchronous control of a number of units and for remote control pressure (plugged)	M 14x1,5
X	Pilot pressure port	M 14x1,5
T	Case drain port	M 26x1,5
U	Flushing port (plugged)	M 22x1,5
M <sub>1</sub>	Test port for control pressure (plugged)	M 14x1,5

### Unit Dimensions Size 160

Before finalising your design, please request a certified drawing.

#### Hydraulic control, pilot pressure related HD1, HD2 Hydraulic two-position control HZ1

Service line ports A/B on (opposite) sides (02)

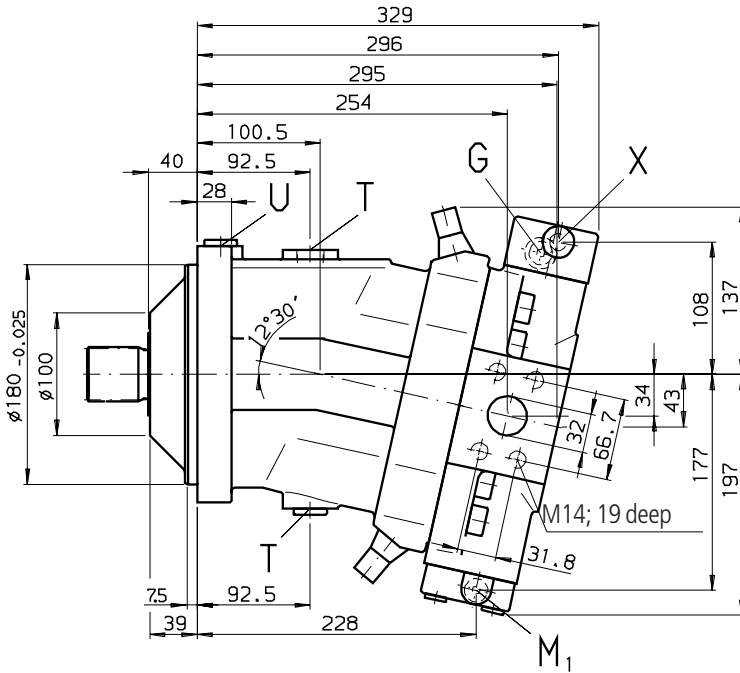

View Z

Service line ports A/B on (opposite) sides (02)

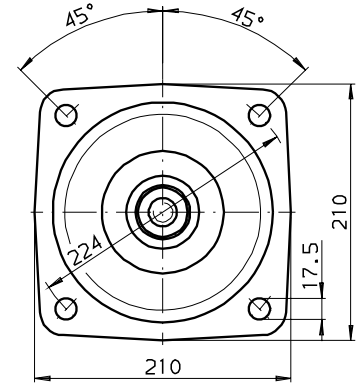

Service line ports A/B at rear end (01)

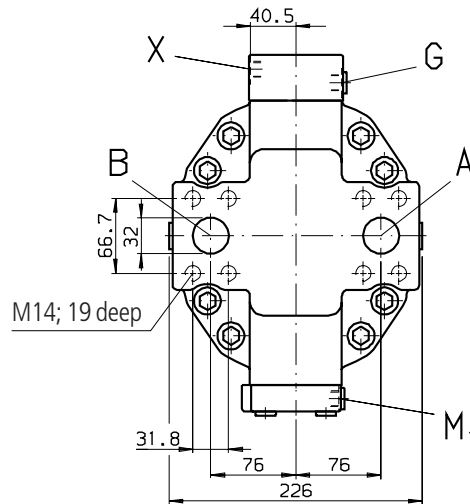
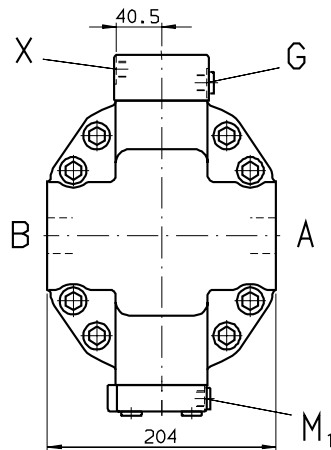

#### Shaft ends

**A**  
Splined shaft  
W 50x2x30x24x9g  
DIN 5480

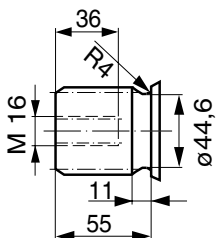

**Z**  
Splined shaft,  
W 45x2x30x21x9g  
DIN 5480

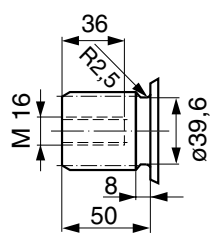

#### Connections

A; B	Service line ports 420 bar (6000 psi) high pressure series	SAE 1 <sup>1</sup> / <sub>4</sub> "
G	Port for synchronous control of a number of units and for remote control pressure (plugged)	M 14x1,5
X	Pilot pressure port	M 14x1,5
T	Case drain port	M 26x1,5
U	Flushing port (plugged)	M 22x1,5
M <sub>1</sub>	Test port for control pressure (plugged)	M 14x1,5

## Unit Dimensions Size 200

Before finalising your design, please request a certified drawing.

### Hydraulic control, pilot pressure related HD1, HD2 Hydraulic two-position control HZ1

Service line ports A/B on (opposite) sides (02)

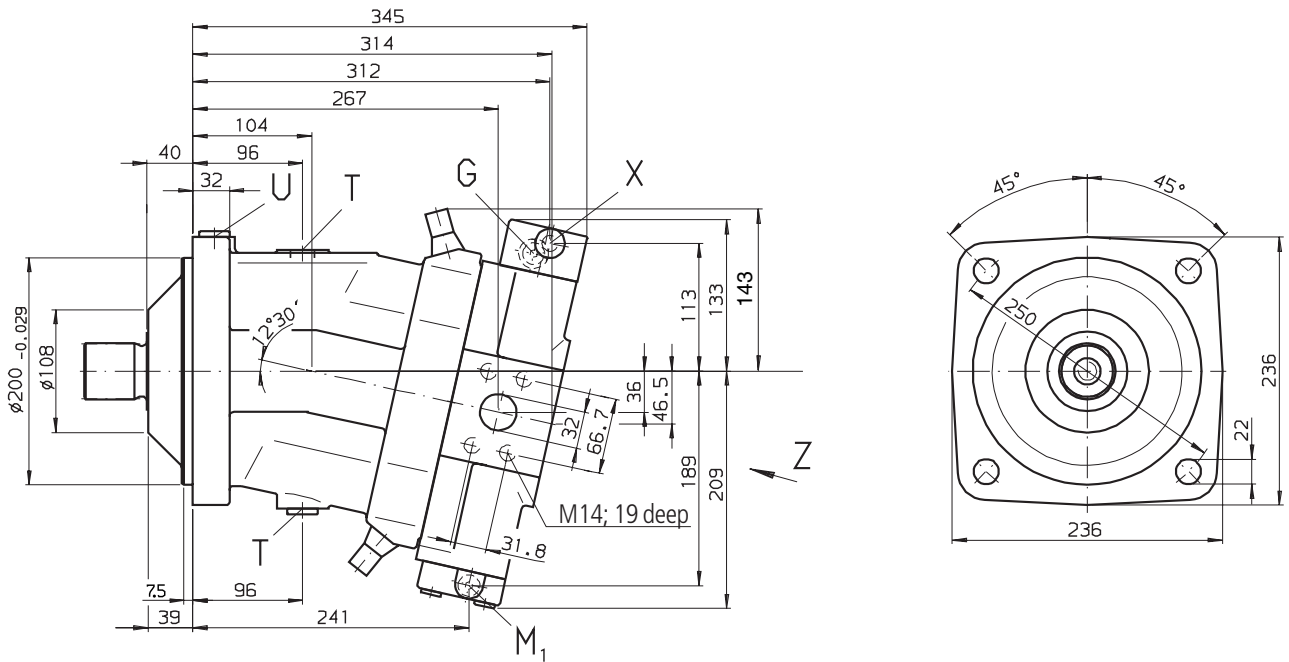

View Z

Service line ports A/B on (opposite) sides (02)

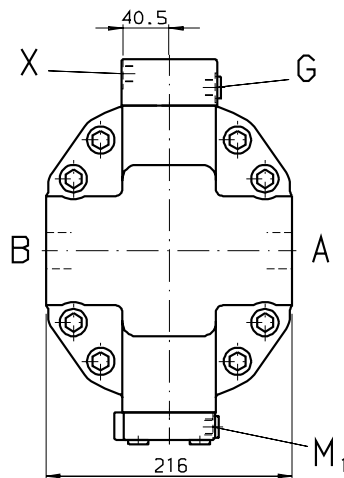

Service line ports A/B at rear end (01)

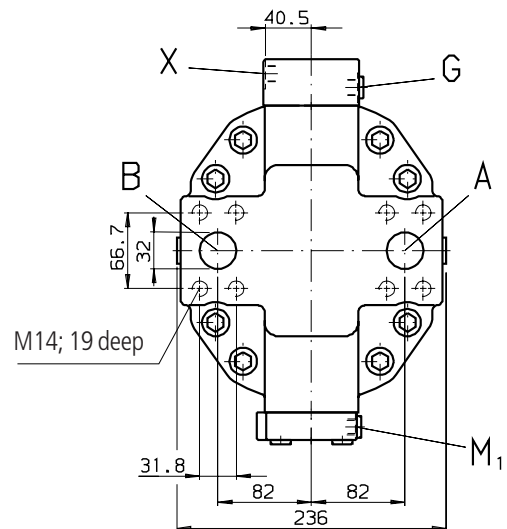

### Shaft ends

#### A

Splined shaft  
W 50x2x30x24x9g  
DIN 5480

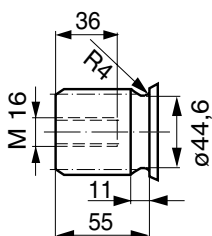

### Connections

A; B	Service line ports 420 bar (6000 psi) high pressure series	SAE 1 1/4"
G	Port for synchronous control of a number of units and for remote control pressure (plugged)	M 14x1,5
X	Pilot pressure port	M 14x1,5
T	Case drain port	M 26x1,5
U	Flushing port (plugged)	M 22x1,5
M <sub>1</sub>	Test port for control pressure (plugged)	M 14x1,5

### Unit Dimensions Size 250

Before finalising your design, please request a certified drawing.

Hydraulic control, pilot pressure related HD1, HD2, HD3  
Hydraulic two-position control HZ

Service line ports A/B on (opposite) sides (02); on (opposite) sides + at rear end (15)

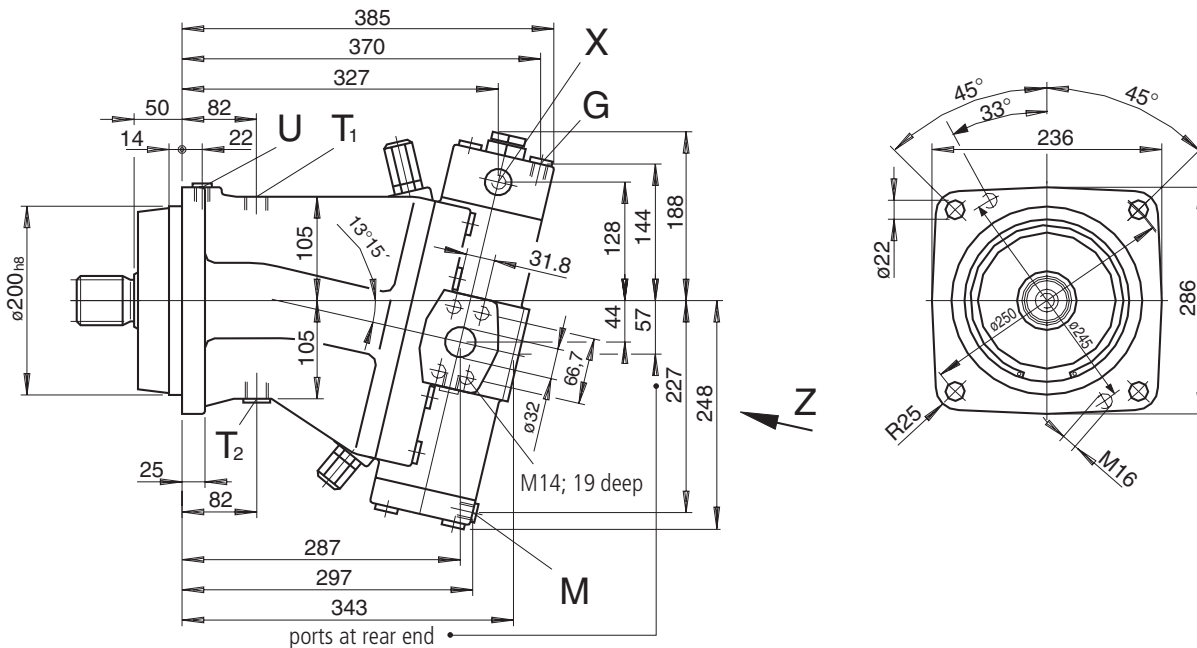

View Z

Service line ports A/B on (opposite) sides (02)

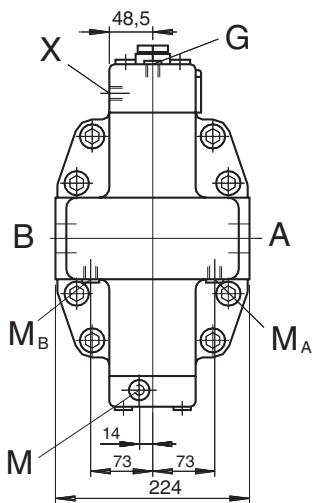

Service line ports A/B at rear end (01)

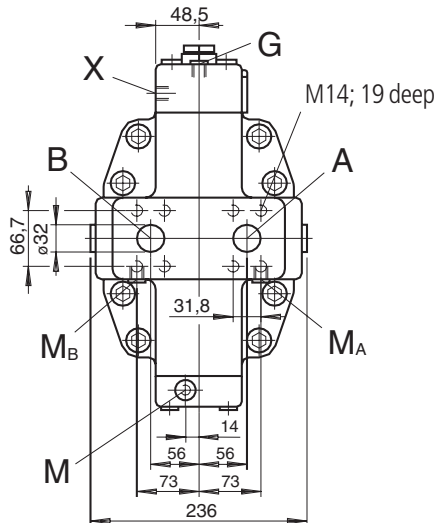

Service line ports A/B/A<sub>1</sub>/B<sub>1</sub> on (opposite) sides + at rear end (15)

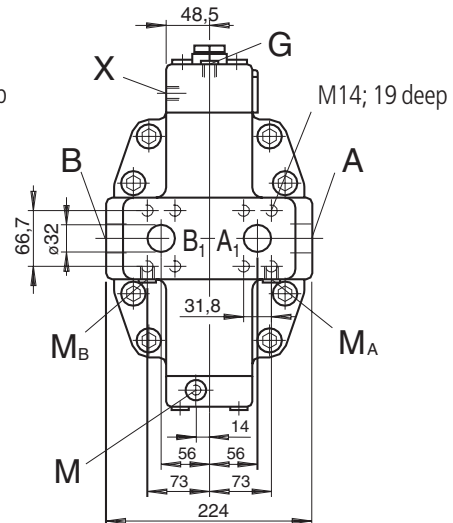

#### Shaft ends

**Z**  
Splined shaft  
W 50x2x30x24x9g  
DIN 5480

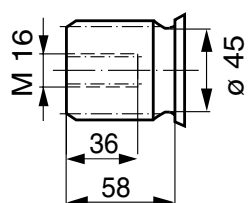

**P**  
Parallel shaft  
with key AS 14x9x80  
DIN 6885

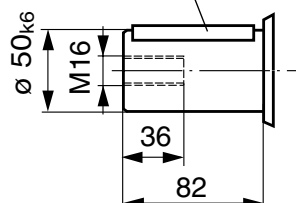

#### Connections

A; B	Service line ports high pressure series	SAE 1 1/4"
A <sub>1</sub> ; B <sub>1</sub>	Additional service line ports at port plate 15	SAE 1 1/4"
G	Port for synchronous control of a number of units and for remote control pressure (plugged)	M 14x1,5
X	Pilot pressure port	M 14x1,5
T <sub>1</sub> , T <sub>2</sub>	Case drain ports	M 22x1,5
U	Flushing port	M 14x1,5
M <sub>A</sub> , M <sub>B</sub>	Test ports	M 14x1,5
M	Test port for control pressure (plugged)	M 14x1,5



Unit Dimensions Size 500

Before finalising your design, please request a certified drawing.

Hydraulic control, pilot pressure related HD1, HD2, HD3  
 Hydraulic two-position control HZ

Service line ports A/B on (opposite) sides (02); on (opposite) sides + at rear end (15)

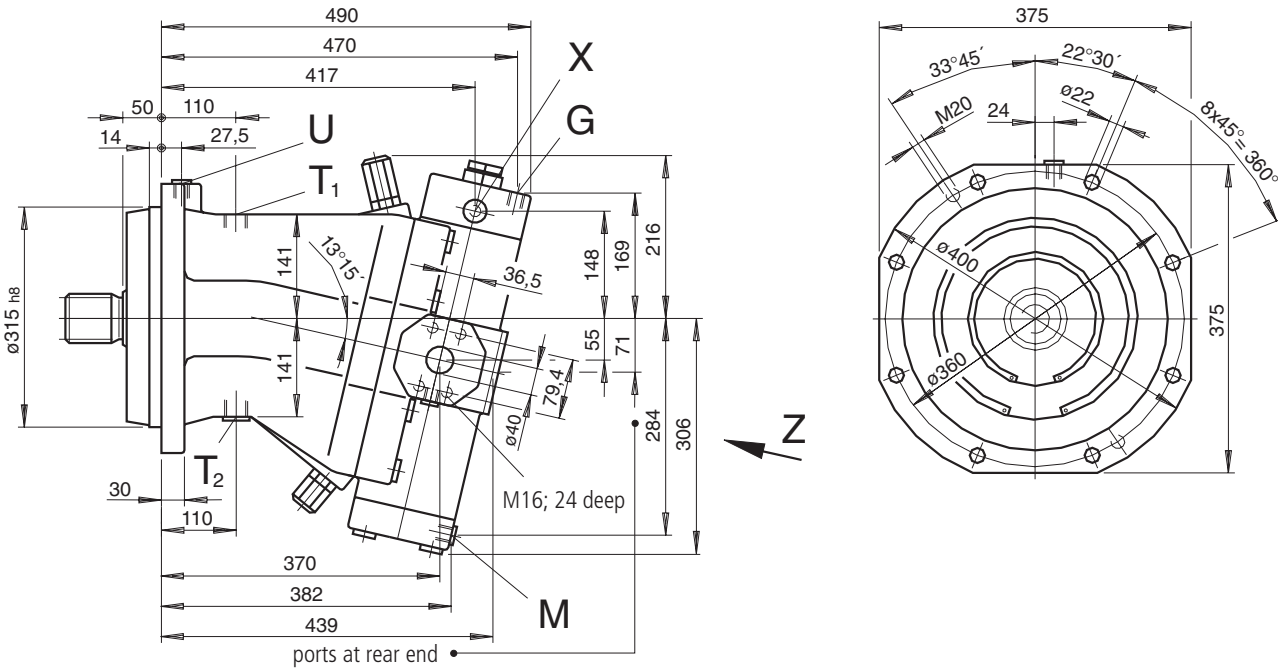

View Z

Service line ports A/B on (opposite) sides (02)

Service line ports A/B at rear end (01)

Service line ports A/B/A<sub>1</sub>/B<sub>1</sub> on (opposite) sides + at rear end (15)

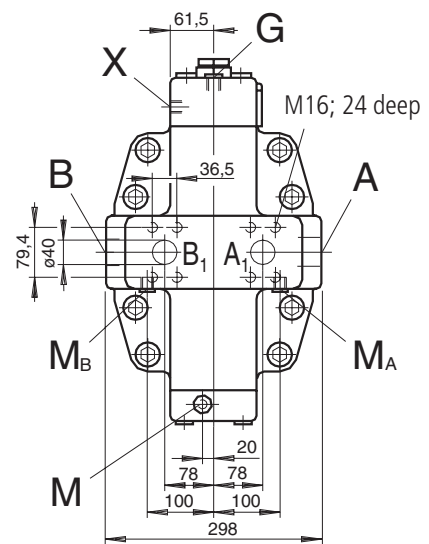
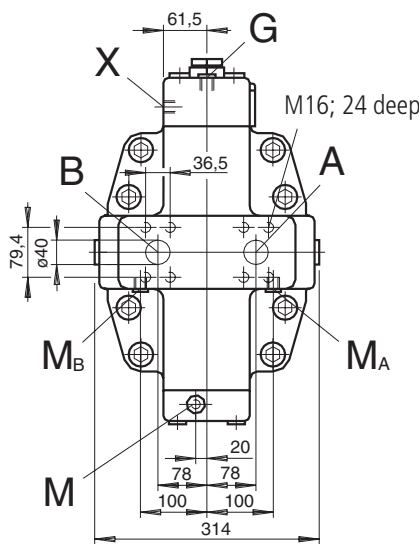
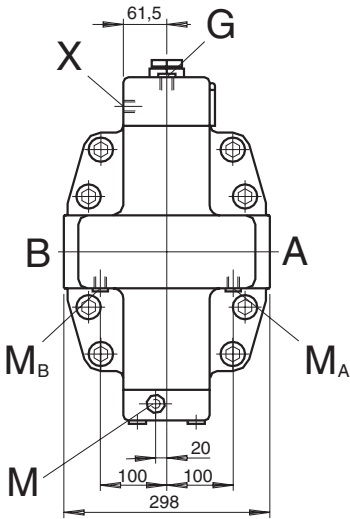

Shaft ends

**Z**  
 Splined shaft  
 W 70x3x30x22x9g  
 DIN 5480

**P**  
 Parallel shaft  
 with key AS 20x12x100  
 Din 6885

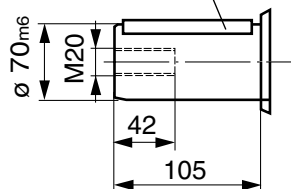
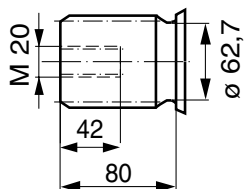

Connections

A, B	Service line ports high pressure series	SAE 1 1/2"
A <sub>1</sub> ; B <sub>1</sub>	Additional service line ports at port plate 15	SAE 1 1/2"
G	Port for synchronous control of a number of units and for remote control pressure (plugged)	M 18x1
X	Pilot pressure port	M 14x1,5
T <sub>1</sub> , T <sub>2</sub>	Case drain ports	M 33x2
U	Flushing port	M 18x1,5
M <sub>A</sub> , M <sub>B</sub>	Test ports	M 14x1,5
M	Test port for control pressure (plugged)	M 14x1,5



### Unit Dimensions Size 1000

Before finalising your design, please request a certified drawing.

#### Hydraulic control, pilot pressure related HD1, HD2 Hydraulic two-position control HZ

Service line ports A/B on (opposite) sides (02)

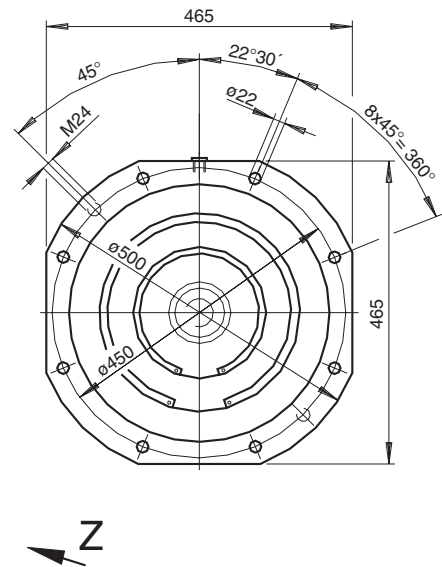
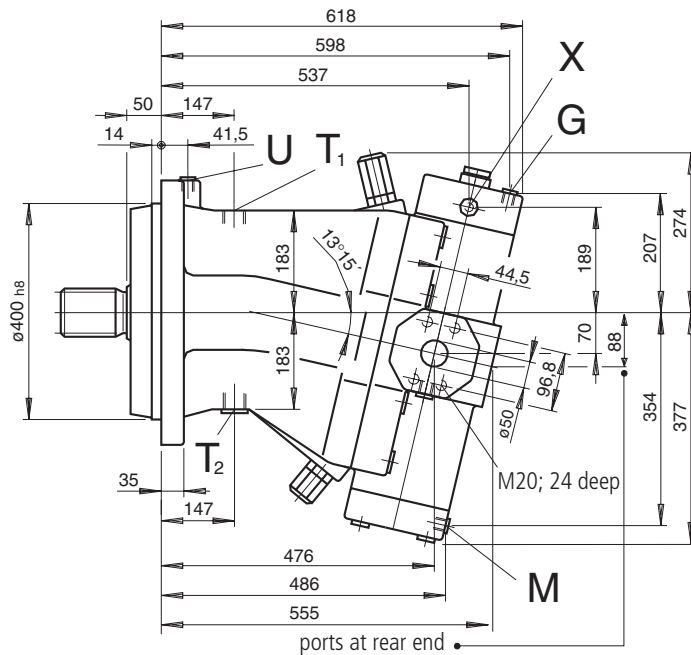

View Z

Service line ports A/B on (opposite) sides (02)

Service line ports A/B at rear end (01)

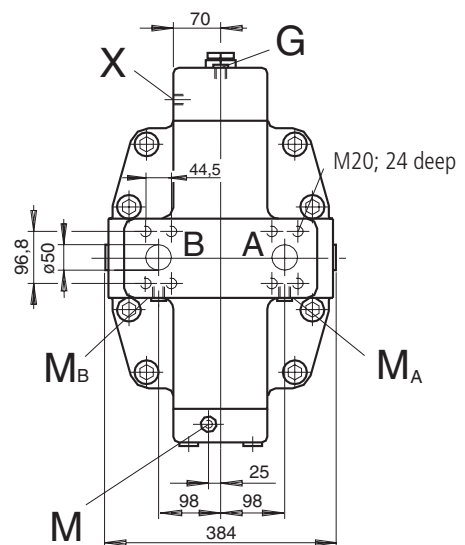
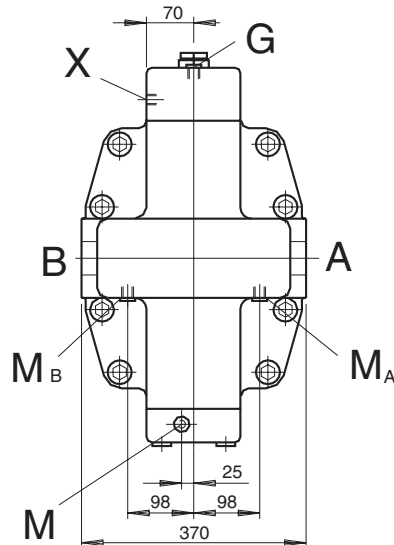

#### Shaft ends

##### Z

Splined shaft  
W 90x3x30x28x9g  
DIN 5480

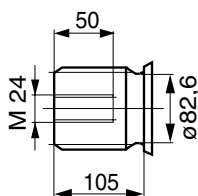

##### P

Parallel shaft  
with key AS 25x14x125  
DIN 6885

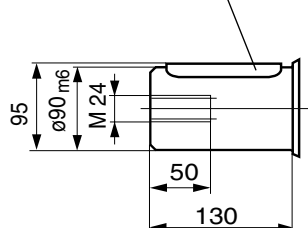

#### Connections

A,B	Service line ports high pressure series	SAE 2 "
G	Port for synchronous control of a number of units and for remote control pressure (plugged)	M 18x1,5
X	Pilot pressure port	M 14x1,5
T <sub>1</sub> , T <sub>2</sub>	Case drain ports	M 42x2
U	Flushing port	M 18x1,5
M <sub>A</sub> , M <sub>B</sub>	Test ports	M 14x1,5
M	Test port for control pressure (plugged)	M 14x1,5





## Flushing and Boost Pressure Valve

Before finalising your design, please request a certified drawing.

The flushing and boost pressure valve is set at a fixed opening pressure of 16 bar and serves to maintain the minimum boost pressure (set primary valve accordingly).

A fixed flow of fluid is taken via an orifice from the low pressure side of the circuit and fed into the motor housing. This flow is then passed back to tank with the case drain fluid. Fluid thus removed from the closed circuit must be made up by means of the boost pump.

The valve is mounted onto the variable motor or integrated in the control device.

Different orifice sizes may be used to select varying flows of flushing fluid.

Sizes 28...200

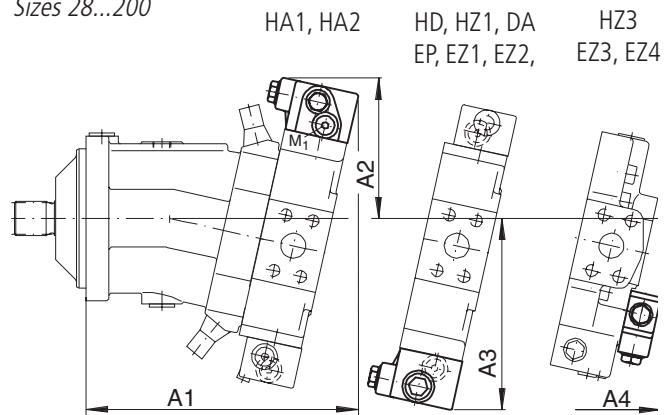

Size	A1	A2	A3	A4
28	214	125	161	—
55	243	133	176	236
80	273	142	193	254
107	288	144	200	269
140	321	154	218	—
160	328	154	220	—
200	345	160	231	—

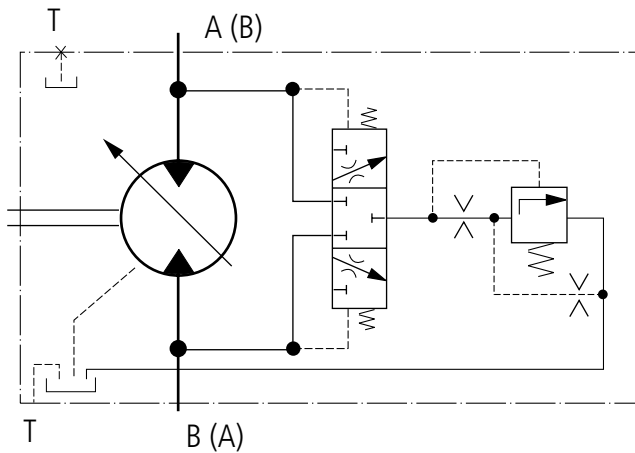

Sizes 250...1000

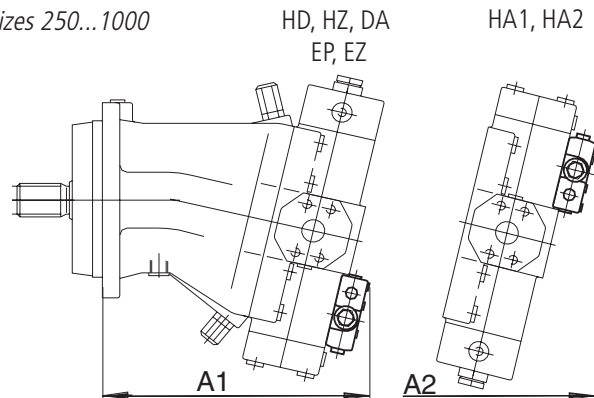

Size	A1	A2
250	357	402
355	397	446
500	440	504
1000	552	—

**Flows** (at low pressure  $\Delta p_{ND} = 25 \text{ bar}$ )\*

Size	Flow	Orifice No.
28, 55	3,5 L/min	651766/503.12.01.01
80	5 L/min	419695/503.12.01.01
107	8 L/min	419696/503.12.01.01
160, 200	10 L/min	419697/503.12.01.01
250	10 L/min	—
355	16 L/min	—
500	20 L/min	—
1000	25 L/min	—

\* standard flushing volumes

(For sizes 28...200 flushing volumes of 3,5 - 10 L/min can be supplied. If a flushing volume different from the standard flushing volume is required, please indicate the requested orifice in clear text when ordering.)

## Speed Sensor

Version A6VM...D ("suitable for fitting speed sensor") includes gearing on the rotary group.

A speed-proportional signal is produced by means of the rotating, splined rotary group which can be picked up by a suitable sensor and fed back for evaluation..

The sensor is screwed into the upper leakage port T (sizes 28...200) respectively in the additional port for the rotational speed sensor (sizes 250...1000). For the sizes 140...200 the port T is equipped with an adapter piece (M18x1,5) for the installation of the sensors.

Size	28	55	80	107	140	160	200
No. of teeth	40	54	58	67	72	75	80
length of thread (mm)	19,9	19,9	19,9	19,9	31,9	31,9	31,9

Size	250	355	500	1000
No. of teeth	78	90	99	
length of thread (mm)	sensor with variable length of thread			

The speed sensor is not included in standard supply.

Suitable sensors (order separately!):

- inductive impulse detector ID (see RE 95130)
- hall effect speed sensor HD (see RE 95134)

Sizes 28...200

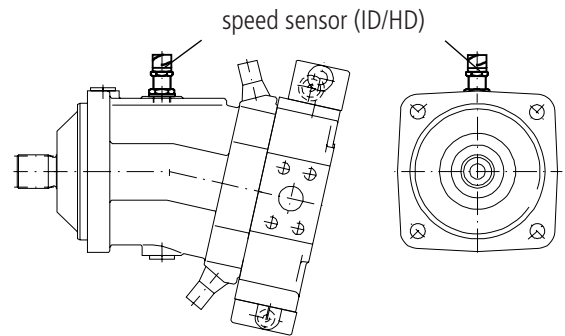

Sizes 250...1000

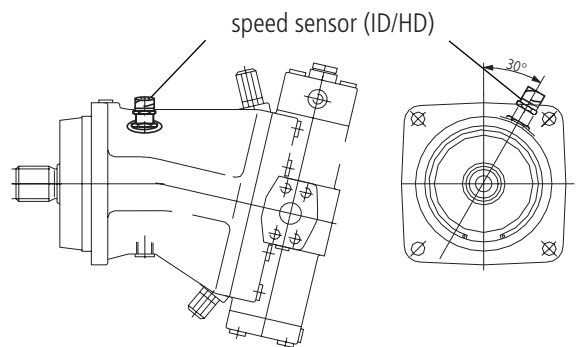

## Swivel Angle Indicator

Before finalising your design, please request a certified drawing.

### Optical swivel angle indicator (V)

The swivel position is indicated by a pin on the side of the housing. (Disassemble of the head nut necessary.) The length of the outstanding pin depends upon the position of the control lens.

If it is flush with the housing the motor is at zero. At max. swivel  $V_{g\ max}$  the length of the pin is 8 mm (Display is still possible if the protective cap is removed).

Sizes 250... 1000 (Example: A6VM...HD, starting position  $V_{g\ max}$ )

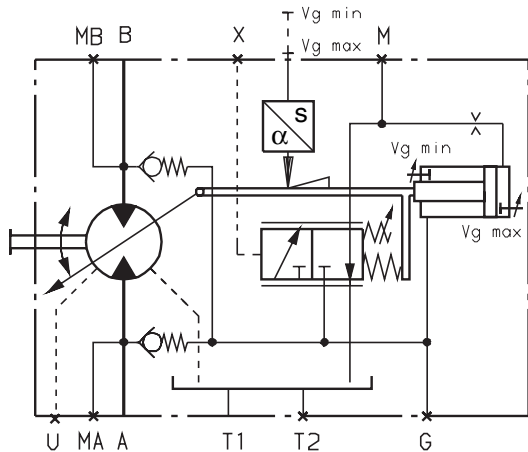

### Electronical swivel angle indicator (E)

The motor position is fed back here by means of an inductive positional transducer. It converts the displacement of the variable unit into an electrical signal.

The swivel position may be further processed by means of this signal, eg. it may be fed to an amplifier card.

Inductive positional transducer type IW9-03-01

Sizes 250... 1000 (Example: A6VM...HA, starting position  $V_{g\ min}$ )

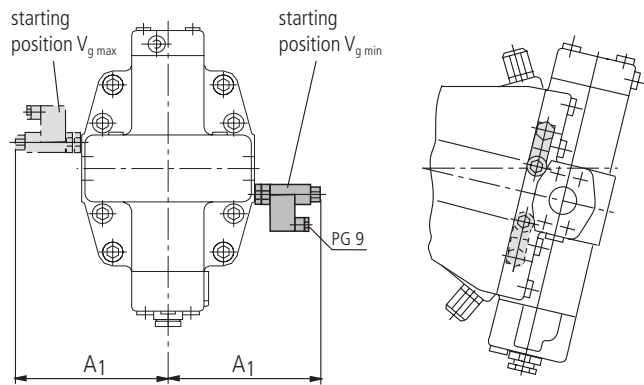
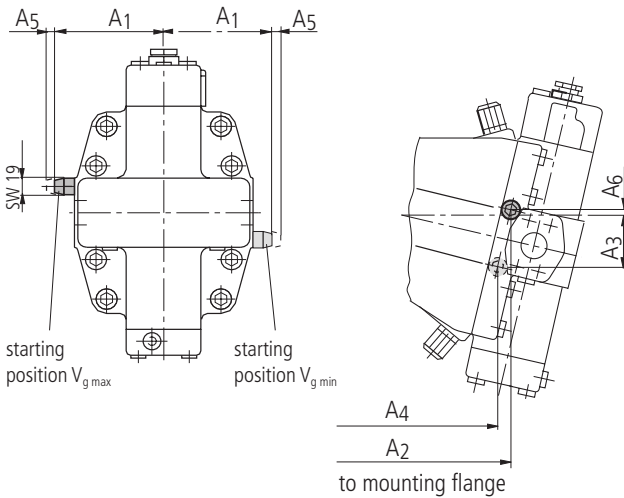
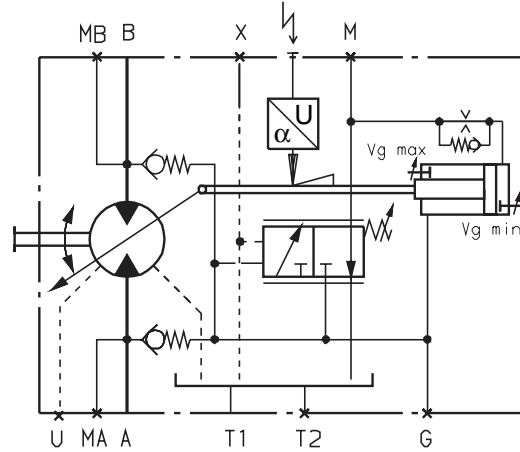

Size	A1	A2	A3	A4	A5 <sup>*)</sup>	A6
250	136,5	256	73	238	11	5
355	159,5	288	84	266	11	8
500	172,5	331	89	309	11	3
1000	208,5	430	114	402	11	3

Size	A1
250	182
355	205
500	218
1000	254

<sup>\*)</sup>space required to remove protective cap

## Preferred Types

Type	Ident-No.	Type	Ident-No.
A6VM28DA1/63W-VZB020B	9604014	A6VM140DA1/63W-VZB020B	9603559
A6VM28DA2/63W-VZB020B	9604015	A6VM140DA3/63W-VZB020B	9610778
A6VM28EP1/63W-VZB020B	9604063	A6VM140EP2/63W-VZB020B	9605666
A6VM28EZ1/63W-VZB020B	9604250	A6VM140EZ2/63W-VZB020B	9610772
A6VM28HA1/63W-VZB020A	9604219	A6VM140HA1/63W-VZB020A	9610774
A6VM28HA1R2/63W-VZB020A	2036653	A6VM140HA1R2/63W-VZB020A	9610776
A6VM28HA1U2/63W-VZB020A	9604665	A6VM140HA1U2/63W-VZB020A	9605670
A6VM28HD1/63W-VZB020B	9603912	A6VM140HD1/63W-VZB020B	9605664
A6VM28HZ1/63W-VZB020B	9604249	A6VM140HZ1/63W-VZB020B	9605648
A6VM55DA1/63W-VZB020B	9604017	A6VM160DA1/63W-VZB020B	9604026
A6VM55DA2/63W-VZB020B	9604018	A6VM160DA3/63W-VZB020B	9604794
A6VM55EP1/63W-VZB020B	9604065	A6VM160EP2/63W-VZB020B	9604072
A6VM55EZ3/63W-VZB020B	9604523	A6VM160EZ2/63W-VZB020B	9604254
A6VM55HA1/63W-VZB020A	9604223	A6VM160HA1/63W-VZB020A	9604235
A6VM55HA1R2/63W-VZB020A	2036655	A6VM160HA1R2/63W-VZB020A	2036656
A6VM55HA1U2/63W-VZB020A	9605637	A6VM160HA1U2/63W-VZB020A	9604666
A6VM55HD1/63W-VZB020B	9603911	A6VM160HD1/63W-VZB020B	9603805
A6VM55HZ3/63W-VZB020B	9604517	A6VM160HZ1/63W-VZB020B	9604252
A6VM80DA1/63W-VZB020B	9604020	A6VM200DA1/63W-VAB020B	9604029
A6VM80DA2/63W-VZB020B	9604021	A6VM200DA3/63W-VAB020B	9610785
A6VM80EP1/63W-VZB020B	9604067	A6VM200EP2/63W-VAB020B	9604074
A6VM80EZ3/63W-VZB020B	9604522	A6VM200EZ2/63W-VAB020B	9604257
A6VM80HA1/63W-VZB020A	9604227	A6VM200HA1/63W-VAB020A	9604239
A6VM80HA1R2/63W-VZB020A	9610911	A6VM200HA1R2/63W-VAB020A	9610792
A6VM80HA1U2/63W-VZB020A	9605641	A6VM200HA1U2/63W-VAB020A	9604667
A6VM80HD1/63W-VZB020B	9603720	A6VM200HD1/63W-VAB020B	9603913
A6VM80HZ3/63W-VZB020B	9604516	A6VM200HZ1/63W-VAB020B	9604255
A6VM107DA1/63W-VZB020B	9604023	A6VM250EP2D/63W2-VZB020B	978 736
A6VM107DA2/63W-VZB020B	9604024	A6VM250HD2D/63W1-VZB020B	983 132
A6VM107EP1/63W-VZB020B	9604069	A6VM250HZ/63W2-VZB027B	999 277
A6VM107EZ3/63W-VZB020B	9604521		
A6VM107EZ4/63W-VZB020B	9611133		
A6VM107HA1/63W-VZB020A	9604231		
A6VM107HA1R2/63W-VZB020A	2011699		
A6VM107HA1U2/63W-VZB020A	9605644		
A6VM107HD1/63W-VZB020B	9603804		
A6VM107HZ3/63W-VZB020B	9604515		

Sizes 28...200: production plant Elchingen

Sizes 250...1000: production plant Horb

Please state type and ident-no. when ordering

Bosch Rexroth AG  
Mobile Hydraulics  
Product Segment Axial Piston Units  
Elchingen Plant  
Glockeraustrasse 2  
89275 Elchingen, Germany  
Telephone +49 (0) 73 08 82-0  
Facsimile +49 (0) 73 08 72 74  
info.brm-ak@boschrexroth.de  
www.boschrexroth.com/brm

Horb Plant  
An den Kelterwiesen 14  
72160 Horb, Germany  
Telephone +49 (0) 74 51 92-0  
Facsimile +49 (0) 74 51 82 21

© 2003 by Bosch Rexroth AG, Mobile Hydraulics, 89275 Elchingen  
All rights reserved. No part of this document may be reproduced or stored, processed, duplicated or circulated using electronic systems, in any form or by any means, without the prior written authorization of Bosch Rexroth AG. In the event of contravention of the above provisions, the contravening party is obliged to pay compensation.  
The data specified above only serve to describe the product. No statements concerning a certain condition or suitability for a certain application can be derived from our information. The given information does not release the user from the obligation of own judgement and verification. It must be remembered that our products are subject to a natural process of wear and aging.