

VPV Vane Pump

Service and Repair Guide



 www.khadamathydraulic.com
Tell: **021-55882749**
Tell: **021-33488178**
Fax: **021-33488105**

Table of Contents

Introduction	2
Benefits	2
Specifications	3
Ordering Guide	6
Performance Characteristics	9
Performance Characteristics - VPV 16 to 3000 PSI (210 Bar)	10
Performance Characteristics - VPV 25 to 3000 PSI (210 Bar)	12
Performance Characteristics - VPV 32 to 3000 PSI (210 Bar)	14
Performance Characteristics - VPV 45 to 3000 PSI (210 Bar)	16
Performance Characteristics - VPV 63 to 3000 PSI (210 Bar)	18
Performance Characteristics - VPV 80 to 3000 PSI (210 Bar)	20
Performance Characteristics - VPV 100 to 3000 PSI (210 Bar)	22
Performance Characteristics - VPV 130 to 3000 PSI (210 Bar)	24
Performance Characteristics - VPV 164 to 3000 PSI (210 Bar)	26
VPV 16, Single pump, S.A.E. 'A' flange, RH rotation, Installation Drawing	28
VPV 16, Single pump, Metric flange, RH rotation, Installation Drawing	29
VPV 25/32, Single pump, S.A.E. 'B' flange, RH rotation, Installation Drawing	30
VPV 25/32, Single pump, Metric flange, RH rotation, Installation Drawing	31
VPV 25/32, Single pump, S.A.E. 'B' flange, RH rotation, Installation Drawing	32
VPV 25/32, Single pump, S.A.E. 'B' flange, w/ solenoid 2-pressure compensator, Inst. Drw.	33
VPV 25/32, Single pump, S.A.E. 'B' flange, w/ NG6 pilot valve, Installation Drawing	34
VPV 45/63/80, Single pump, S.A.E. 'C' flange, RH rotation, Installation Drawing	35
VPV 45/63/80, Single pump, Metric flange, RH rotation, Installation Drawing	37
VPV 100/130/164, Single pump, S.A.E. 'D' flange, RH rotation, Installation Drawing	39
VPV 100/130/164, Single pump, Metric flange, RH rotation, Installation Drawing	41
VPV 16, Combination pump, S.A.E. 'A' flange, RH rotation, Installation Drawing	43
VPV 25/32, Combination pump, S.A.E. 'B' flange, RH rotation, Installation Drawing	44
VPV 32/16, Combination pump, S.A.E. 'B' flange, RH rotation, Installation Drawing	45
VPV 32/25, Combination pump, S.A.E. 'F' Gear pump, RH rotation, Installation Drawing	46
VPV 45/63/80 to VPV 16, S.A.E. & Metric Combination, Installation Drawing	47
VPV 45/63/80 to VPV 25/32, S.A.E. & Metric Combination, Installation Drawing	50
VPV 45/63/80 to an 'F' Gear pump, S.A.E. & Metric Combination, Installation Drawing	53
VPV 45/63/80 to an 'G' Gear pump, S.A.E. & Metric Combination, Installation Drawing	56
VPV 45/63/80 to VPV 45/63/80, S.A.E. & Metric Combination, Installation Drawing	58
VPV 100/130/164 to VPV 100/130/164 S.A.E. & Metric Combination, Installation Drawing	62
VPV 100/130/164 to VPV 16 S.A.E. & Metric Combination, Installation Drawing	64
VPV 100/130/164 to VPV 25/32 S.A.E. & Metric Combination, Installation Drawing	67
VPV 100/130/164 to VPV 45/63/80 S.A.E. & Metric Combination, Installation Drawing	70
VPV 100/130/164 to 'F' Gear pump, S.A.E. & Metric Combination, Installation Drawing	73
VPV Controls	77
Comparison of Sound Levels	79
Trouble Shooting	80
Adapter Kits for VPV Combinations Using P1 Pumps	81
Through Drive Horsepower Limitations	82
VPV Stroke Limiter Adjustment	83
2000 PSI Repair Parts	84
3000 PSI Repair Parts	90
Vane Tip Orientation	95
VPV Tool Kit	96
Reaction Characteristics and Shock Clipper Function	97

Introduction

This catalog introduces a new line of enhanced performance variable displacement pressure compensated vane pumps from Bosch.

The pumps are designed to meet the requirements of the machine tool, general machinery, and other markets where low noise, high performance and competitive pricing are needed.

The design of the VPV series of vane pumps utilizes 30 years of field and manufacturing experience from the current Bosch vane pump line. State-of-the-art technologies and materials were utilized while retaining the superior features of the existing designs. Additional goals were to create a pump with the international market in mind and to incorporate the extremely high quality standards the Bosch name has come to exemplify.

Keeping in mind market expectations, Bosch developed a pump with the following improvements and features:

1. High reliability with fewer parts.
2. Significant advances in noise reduction.
3. High volumetric and overall efficiency.
4. Excellent durability.
5. Modern appearance.
6. Improved ring and vane wear technology.
7. Very good response and recovery times.
8. Generally reduced envelope size.
9. Redesigned controls with shock clipper.
10. Conforms to the latest SAE, ISO, NFPA, and ANSI standards.
11. Combination capability - full horsepower may be transferred to pump 2. Combinations of construction of multiple pumps may be required to be de-rated.

Benefits

- **LOW COST** - Competitively priced with other manufacturers of vane pumps and economy axial piston pumps.
- **EXCEPTIONALLY QUIET** - Helps machinery builders meet government and purchased sound level requirements.
- **CONTINUOUS DUTY RATING** - @ 3,000 PSI - High performance and long life design for 10,000 plus hours.
- **HIGHLY EFFICIENT FAST RESPONSE & RECOVERY** - Exceptional reaction time for critical system demands.
- **PRESSURE COMPENSATED** - Controls pump delivery to circuit demand thereby conserving energy.
- **HIGH STRENGTH** - Computer optimized casting design.
- **HYDRODYNAMIC JOURNAL BEARINGS** - Provides long life and quiet operation.
- **NO PREFILL REQUIREMENTS** - Pump case prefill not required for initial start-ups.
- **REPAIRABLE** - Repair kits and parts available from local distribution centers or the factory.
- **CONTROL OPTIONS** - Single stage; two-stage, remote control; solenoid multi-pressure; load sensing; solenoid; torque limiting and electronic proportional.
- **SHOCK CLIPPER** - Reduces shock pressure by up to 50% increasing system component life and system stability. Must be plumbed on VPV 16, 25, & 32. The shock clipper is integrated into VPV 45, 63, 80, 100, 130, & 164 and drains to the case drain. See page 97.

Specifications

General		VPV 16	VPV 25	VPV 32
Displacement (Nominal)		1 in ³ /rev (16 cm ³ /rev)	1.5 in ³ /rev (25 cm ³ /rev)	2 in ³ /rev (32 cm ³ /rev)
Displacement (Actual)		1.06 in ³ /rev (16.8 cm ³ /rev)	1.66 in ³ /rev (27.4 cm ³ /rev)	2.04 in ³ /rev (32 cm ³ /rev)
Flow at 1750 RPM ¹		7.57 GPM (28.6 L/min)	11.36 GPM (43.0 L/min)	15.15 GPM (57.3 L/min)
Maximum continuous pressure		3000 psi (210 bar)		
Pressure compensating range	Single stage	200-3000 psi (14-210 bar) Minimum pressure of 190 PSI		
	Two stage	300-3000 psi (20-210 bar) Minimum pressure of 290 PSI		
Maximum transient spike pressure		3800 psi (260 bar)	4000 psi (280 bar)	
Maximum case pressure		10 psi (0.7 bar)		
Speed range		1150-1800 RPM		
Direction of rotation (viewed from shaft end)		Right hand (clockwise)		
Case drain flow while compensating @ 1800 RPM	1000 psi (70 bar)	0.6 GPM (2.3 L/min)	0.6 GPM (2.3 L/min)	
	2000 psi (140 bar)	0.9 GPM (3.4 L/min)	1.1 GPM (4.2 L/min)	
	3000 psi (210 bar)	1.26 GPM (4.8 L/min)	1.4 GPM (5.3 L/min)	
Maximum inlet vacuum at sea level		6 in. HG (152 mm HG)		
Mounting ² - SAE 2-bolt flange (ISO 3019/1)		S.A.E. 'A' 2-bolt flange	S.A.E. 'B' 2-bolt flange	
Mounting Position		Unrestricted		
Port sizes	Inlet	#16 S.A.E.	#24 S.A.E	
	Outlet	#12 S.A.E.	#16 S.A.E.	
	Case drain	#8 S.A.E.		
	Clipper control drain (optional)	#6 S.A.E.		
	Remote control (optional)	#4 S.A.E.		
Drive		Pump to be connected to prime mover by means of a flexible coupling that is aligned to a maximum of .006" (.152mm) total indicator reading. No overhung or side loads permitted. Alignments greater than .006" indicator reading could cause increased noise and vibration as well as premature shaft seal wear resulting in leakage.		
Fluid recommendations		A premium quality hydraulic oil with anti-wear additives is recommended, but not required. Refer to publication S-106 "Petroleum Hydraulic Fluids" for a list of fluids which meet or exceed the necessary lubrication requirements. Consult factory for use with water base fire resistant fluids.		
Fluid viscosity at operating temperature	Minimum	100 SUS (21 cSt)		
	Maximum	1000 SUS (216 cSt)		
	Optimum	150-250 SUS (32-54 cSt)		
	Maximum start-up	4000 SUS (864 cSt)		
Fluid temperature		Normal inlet fluid temperature should not exceed 140°F (60° C). Always select a fluid for optimum viscosity at operating temperature. Consult factory for applications assistance when inlet fluid temperatures over 140° F (60° C) are expected.		
Seals		Fluorocarbon Standard		
Filtration		Fluid cleanliness per ISO/DIS 4406 should be 18/15 or better for pressures of 2000 psi or less. For continuous operating pressures of 2000 to 3000 psi, fluid cleanliness should be 17/13 or better.		
Response time (circuit dependent)	Full flow to minimum flow	20-35 ms	20-35 ms	
Recovery time (circuit dependent)	Minimum flow to full flow	50-135 ms – single stage compensator	70-185 ms – single stage compensator	
Weight	Single stage	34 lbs. (16.5 kg)	61 lbs. (28 kg)	
	Two stage	38 lbs. (17.3 kg)	65 lbs. (28.5 kg)	

¹ Flows are actual. Volumetric efficiencies shown in technical data taken into account.

² Metric 4-bolt flange available (ISO 3019/2) available. Please consult factory.

Specifications

General		VPV 45	VPV 63	VPV 80
Displacement (Nominal)		2.75 in ³ /rev (45 cm ³ /rev)	3.84 in ³ /rev (63 cm ³ /rev)	4.88 in ³ /rev (80 cm ³ /rev)
Displacement (Actual)		2.88 in ³ /rev (47.3 cm ³ /rev)	3.93 in ³ /rev (64.4 cm ³ /rev)	5.02 in ³ /rev (82.3 cm ³ /rev)
Flow at 1750 RPM ¹		20.83 GPM (72.84 L/min)	29.10 GPM (110.1 L/min)	36.97 GPM (139.9 L/min)
Maximum continuous pressure		3000 psi (210 bar)		
Pressure compensating range Two stage		350-3000 psi (24-210 bar) Minimum pressure of 300 PSI		
Maximum transient spike pressure		4000 psi (280 bar)		
Maximum case pressure		10 psi (0.7 bar)		
Speed range		1150-1800 RPM		
Direction of rotation (viewed from shaft end)		Right hand (clockwise)		
Case drain flow	1000 psi (70 bar)	1.5 GPM (5.7 L/min)	1.4 GPM (5.3 L/min)	1.4 GPM (5.3 L/min)
	while compensating 2000 psi (140 bar)	1.9 GPM (7.2 L/min)	1.8 GPM (6.8 L/min)	1.8 GPM (6.8 L/min)
	@ 1800 RPM 3000 psi (210 bar)	2.5 GPM (9.5 L/min)	2.4 GPM (9.1 L/min)	2.3 GPM (8.7 L/min)
Maximum inlet vacuum at sea level		6 in. HG (152 mm HG)		
Mounting ² - SAE 2-bolt flange (ISO 3019/1)		S.A.E. 'C' 2-Bolt flange		
Mounting Position		Unrestricted		
Port sizes	Inlet	2" S.A.E.		
	Outlet	1 1/4" S.A.E. flange		
	Case drain	S.A.E. = #8 S.A.E.		
	Remote control (optional)	S.A.E. = #4 S.A.E.		
Drive		Pump to be connected to prime mover by means of a flexible coupling that is aligned to a maximum of .006" (.152mm) total indicator reading. No overhung or side loads permitted. Alignments greater than .006" indicator reading could cause increased noise and vibration as well as premature shaft seal wear resulting in leakage.		
Fluid recommendations		A premium quality hydraulic oil with anti-wear additives is recommended, but not required. Refer to publication S-106 "Petroleum Hydraulic Fluids" for a list of fluids which meet or exceed the necessary lubrication requirements. Consult factory for use with water base fire resistant fluids.		
Fluid viscosity at operating temperature	Minimum	150 SUS (32 cSt)		
	Maximum	1000 SUS (216 cSt)		
	Optimum	200-300 SUS (43-65 cSt)		
	Maximum start-up	4000 SUS (864 cSt)		
Fluid temperature		Normal inlet fluid temperature should not exceed 140°F (60° C). Always select a fluid for optimum viscosity at operating temperature. Consult factory for applications assistance when inlet fluid temperatures over 140° F (60° C) are expected.		
Seals		Fluorocarbon Standard		
Filtration		Fluid cleanliness per ISO/DIS 4406 should be 18/15 or better for pressures of 2000 psi or less. For continuous operating pressures of 2000 to 3000 psi, fluid cleanliness should be 17/13 or better.		
Response time (circuit dependent)	Full flow to minimum flow	20-40 ms		
Recovery time (circuit dependent)	Minimum flow to full flow	100-250 ms – two stage compensator		
Weight	Single stage	120 lbs. (55 kg)		
	Two stage	128 lbs. (58 kg)		

¹ Flows are actual. Volumetric efficiencies shown in technical data taken into account.

² Metric 4-bolt flange available (ISO 3019/2) available. Please consult factory.

Specifications

General		VPV 100	VPV 130	VPV 164
Displacement (Nominal)		6.1 in ³ /rev (100 cm ³ /rev)	7.9 in ³ /rev (130 cm ³ /rev)	10.0 in ³ /rev (164 cm ³ /rev)
Displacement (Actual)		6.0 in ³ /rev (99 cm ³ /rev)	8.0 in ³ /rev (131 cm ³ /rev)	10.0 in ³ /rev (164 cm ³ /rev)
Flow at 1750 RPM ¹		45.4 GPM (171.8 L/min)	59.85 GPM (226.5 L/min)	75.76 GPM (286.7 L/min)
Maximum continuous pressure		3000 psi (210 bar)		3000 psi (210 bar)
Pressure compensating Two stage		350-3000 psi (24-210 bar)		350-3000 psi (24-210 bar)
Maximum transient spike pressure		4000 psi (280 bar)		4000 psi (280 bar)
Maximum case pressure		10 psi (0.7 bar)		
Speed range		1150-1800 RPM		
Direction of rotation (viewed from shaft end)		Right hand (clockwise)		
Case drain flow	1000 psi (70 bar)	1.5 GPM (5.7 L/min)	1.6 GPM (6.0 L/min)	1.7 GPM (6.4 L/min)
	while compensating 2000 psi (140 bar)	2.0 GPM (7.6 L/min)	2.2 GPM (8.3 L/min)	2.3 GPM (8.7 L/min)
	@1800 RPM 3000 psi (210 bar)	2.5 GPM (9.5 L/min)	3.0 GPM (11.3 L/min)	3.1 GPM (11.7 L/min)
Maximum inlet vacuum at sea level		6 in. HG (152 mm HG)		
Mounting ² - SAE 2-bolt flange (ISO 3019/1)		S.A.E. 'D', 2-bolt flange		
Mounting Position		Unrestricted		
Port sizes	Inlet	2 1/2" S.A.E.		
	Outlet	1 1/2" S.A.E.		
	Case drain	S.A.E. = #8 S.A.E.		
	Remote control (optional)	#4 S.A.E.		
Drive		Pump to be connected to prime mover by means of a flexible coupling that is aligned to a maximum of .006" (.152mm) total indicator reading. No overhung or side loads permitted. Alignments greater than .006" indicator reading could cause increased noise and vibration as well as premature shaft seal wear resulting in leakage.		
Fluid recommendations		A premium quality hydraulic oil with anti-wear additives is required*. Refer to publication S-106 "Petroleum Hydraulic Fluids" for a list of fluids which meet or exceed the necessary lubrication requirements. Consult factory for use with water base fire resistant fluids. *Such as Mobil DTE-26, or similar, for pressures over 2000 psi.		
Fluid viscosity at operating temperature	Minimum	150 SUS (32 cSt)		
	Maximum	1000 SUS (216 cSt)		
	Optimum	200-300 SUS (42-65 cSt)		
	Maximum start-up	4000 SUS (864 cSt)		
Fluid temperature		Normal inlet fluid temperature should not exceed 140°F (60° C). Always select a fluid for optimum viscosity at operating temperature. Consult factory for applications assistance when inlet fluid temperatures over 140° F (60° C) are expected.		
Seals		Fluorocarbon Standard		
Filtration		Fluid cleanliness per ISO/DIS 4406 should be 18/15 or better for pressures of 2000 psi or less. For continuous operating pressures of 2000 to 3000 psi, fluid cleanliness should be 17/13 or better.		
Response time (circuit dependent)	Full flow to minimum flow	20-50 ms		
Recovery time (circuit dependent)	Minimum flow to full flow	250-500 ms – two stage compensator		
Weight	Single stage	240 lbs. (109 kg)		
	Two stage	248 lbs. (112.7 kg)		

¹ Flows are actual. Volumetric efficiencies shown in technical data taken into account.

² Metric 4-bolt flange available (ISO 3019/2) available. Please consult factory.

Ordering Guide

Code Structure

The alpha-numeric ordering code system enables any particular type of pump to be specified. Preferred type are also identified by a 10-digit part number for computerized ordering.

Item No.	1	2	3	4	5	6	7	8	9	10	11	12	13	14	15
Pump 1	0513	R	18	C	3	V	P	V	32	S	M	21	F	Z	B02
Pump 2***						V	P	V	32	S	M	21	F	Z	B02
Pump 3 (Gear Pump)						HY/Z	F	S11/	14	R	254				

Item No	Code	
1		Code Digit
	0513	Vane Pump, stand alone version single pump or combination
2		Direction of Rotation
	R	Clockwise, viewed from shaft end
3		Speed
	12	maximum speed; e.g. 1150 rpm = 12
	15	1450 rpm = 15
	18	1750 rpm = 18
4		Drive Shaft
	A	Key to DIN 6885
	C	Key to SAE Standard
	D	Spline to SAE 744C
5		Bearing Arrangement / Mounting Flange
	3	Standard bearing arrangement, mounting flange to SAE standards
	7	Standard bearing arrangement, mounting flange to DIN ISO 3019/2
6		Principle of Operation
	V	Vane Type
7		Mode of Operation
	P	Pump
8		Type of Construction
	V	Variable displacement pump (open circuit)
	K	Fixed Displacement Pump (available in 1998)
9		Displacement
	16	16 cc/rev = .98 cu in/rev
	25	25 cc/rev = 1.53 cu in/rev
	32	32 cc/rev = 1.95 cu in/rev
	45	45 cc/rev = 2.75 cu in/rev
	63	63 cc/rev = 3.84 cu in/rev
	80	80 cc/rev = 4.88 cu in/rev
	100	100 cc/rev = 6.10 cu in/rev
	130	130 cc/rev = 7.93 cu in/rev
	164	164 cc/rev = 10.00 cu in/rev

*** When trailing pump is another VPV pump, it can be coded by selecting items 6 through 15 for the alpha-numeric description. Consult factory for other models and descriptions of trailing pumps.

Price and Part Numbers

See VPV Pump Identification Guide, Publication # 9 535 233 782 for SAE, and 9 535 233 785 for metric pumps.

Product Literature Disclaimer

Specifications and/or dimensions are subject to change without prior notice. Please consult factory.

Ordering Guide, cont.

Item No	Code	
10		Housing
	S	210 bar = 3000 psi.
11		Operating Fluid
	C	Water glycol
	M	Mineral Oil
	D	Phosphate ester
12		Operating Pressure
	14	Maximum operating pressure; e.g. 14 = 140 bar = 2000 psi
	21	21 = 210 bar = 3000 psi
13		Control / Regulator
	F	Pressure regulator - single stage 16/25/32cc only
	G	Pressure regulator - single stage - lockable 16/25/32cc only
	H	Pressure regulator - two stage - with remote option
	J	Combined pressure/flow compensator (load sense)
	S	Torque limiter (available in 45 to 164cc pumps only)
	T	Proportional P/Q (available 1998)
		Solenoid Operated Two Press. Norm. (Normally open)/Normally Low Pressure/Energize to High
	XA	115V N.O. w/DIN 43650 & quick connect (compression fitting) w/sentinel light
	XB	220V N.O. w/DIN 43650 & quick connect (compression fitting) w/sentinel light
	XC	12V N.O. w/DIN 43650 & quick connect (compression fitting) w/sentinel light
	XD	24V N.O. w/DIN 43650 & quick connect (compression fitting) w/sentinel light
	XE	115V N.O. w/flying leads
	XF	220V N.O. w/flying leads
	XG	12V N.O. w/flying leads
	XH	24V N.O. w/flying leads
	XJ	115V N.O. w/DIN 43650 & NG6
	XK	220V N.O. w/DIN 43650 & NG6
	XL	12V N.O. w/DIN 43650 & NG6
	XM	24V N.O. w/DIN 43650 & NG6
	XN	115V N.O. w/flying leads & NG6
	XO	220V N.O. w/flying leads & NG6
	XP	12V N.O. w/flying leads & NG6
	XR	24V N.O. w/flying leads & NG6
		Solenoid Operated Two Press. Norm. (Normally closed)/Normally High Pressure/Energize to Low
	YA	115V N.C. w/DIN 43650 & quick connect (compression fitting) w/sentinel light
	YB	220V N.C. w/DIN 43650 & quick connect (compression fitting) w/sentinel light
	YC	12V N.C. w/DIN 43650 & quick connect (compression fitting) w/sentinel light
	YD	24V N.C. w/DIN 43650 & quick connect (compression fitting) w/sentinel light
	YE	115V N.C. w/flying leads
	YF	220V N.C. w/flying leads
	YG	12V N.C. w/flying leads
	YH	24V N.C. w/flying leads
	YJ	115V N.C. w/DIN 43650 & NG6
	YK	220V N.C. w/DIN 43650 & NG6
	YL	12V N.C. w/DIN 43650 & NG6
	YM	24V N.C. w/DIN 43650 & NG6
	YN	115V N.C. w/flying leads & NG6
	YO	220V N.C. w/flying leads & NG6
	YP	12V N.C. w/flying leads & NG6
	YR	24V N.C. w/flying leads & NG6

Ordering Guide, cont.

Item No	Code	
13		Solenoid Operated Vent Two Press. Norm. (Normally vented)/Energize to Pressure
(cont.)	ZA	115V N.V. w/DIN 43650 & quick connect (compression fitting) w/sentinel light
	ZB	220V N.V. w/DIN 43650 & quick connect (compression fitting) w/sentinel light
	ZC	12V N.V. w/DIN 43650 & quick connect (compression fitting) w/sentinel light
	ZD	24V N.V. w/DIN 43650 & quick connect (compression fitting) w/sentinel light
	ZE	115V N.V. w/flying leads
	ZF	220V N.V. w/flying leads
	ZG	12V N.V. w/flying leads
	ZH	24V N.V. w/flying leads
		Solenoid Operated Vented Norm. High (Normally closed)/Normally at Pressure/Energize to Vent
	WA	115V N.C. w/DIN 43650 & quick connect (compression fitting) w/sentinel light
	WB	220V N.C. w/DIN 43650 & quick connect (compression fitting) w/sentinel light
	WC	12V N.C. w/DIN 43650 & quick connect (compression fitting) w/sentinel light
	WD	24V N.C. w/DIN 43650 & quick connect (compression fitting) w/sentinel light
	WE	115V N.C. w/flying leads
	WF	220V N.C. w/flying leads
	WG	12V N.C. w/flying leads
	WH	24V N.C. w/flying leads
14		Accessories
	S	Special (Consult Factory)
	Y	Maximum delivery limiter
	Z	No other accessories
15	B01	Design Series
	P1	Pump 1 of a quick combination unit (adapter kit & coupling required to create a combination-see page 81)

Gear Pump Guide

Item No	Code	
6		Principle of Operation
	HY/Z	Hydraulic Gear Pump
7		Size Range
	F	4 cc to 22.5cc
8		Type of Construction
	S11	Standard version
	S21	Duo (low noise version)
9		Displacement
	4	4 cc/rev = .244 cu in/rev
	5.5	5.5 cc/rev = .335 cu in/rev
	8	8 cc/rev = .488 cu in/rev
	11	11 cc/rev = .671 cu in/rev
	14	14 cc/rev = .854 cu in/rev
	16	16 cc/rev = .976 cu in/rev
	19	19 cc/rev = 1.159 cu in/rev
	22.5	22.5 cc/rev = 1.372 cu in/rev
10		Direction of Rotation
	R	Right hand (clockwise)
11		Details
	254	SAE "A" flange, 2 bolt, SAE keyed shaft
	253	SAE "A" flange, 2 bolt, ANSI spline shaft, 9 T, 16/32 pitch

On the following pages are line graphs of the Performance Characteristics for each of the pumps in our series. Characteristics are shown at 1200 PSI, 1500 PSI and 3000 PSI. Since different geographical areas require different data, please refer to the appropriate graph.

Performance Characteristics - VPV 16 to 3000 PSI (210 Bar)

Data plotted: with oil at 120°F (49°C) Viscosity at 120° = 140 SUS (29.6 cSt)

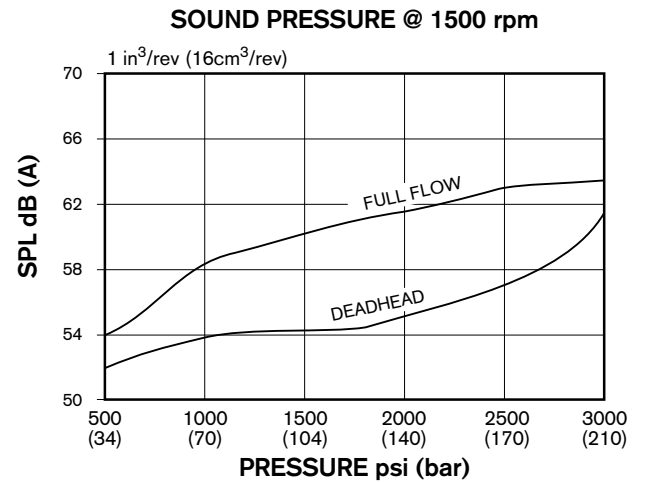
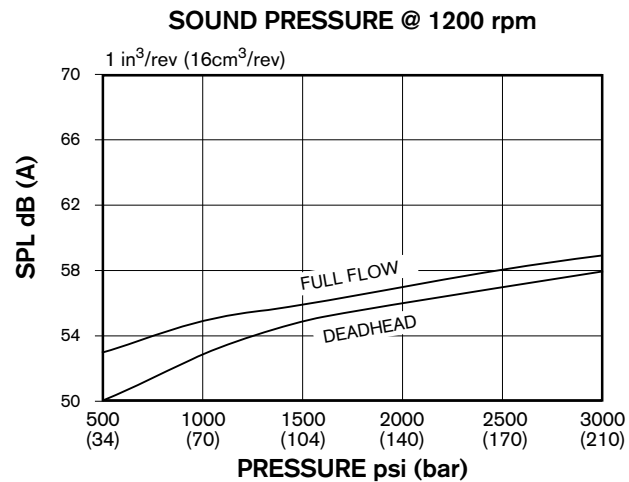
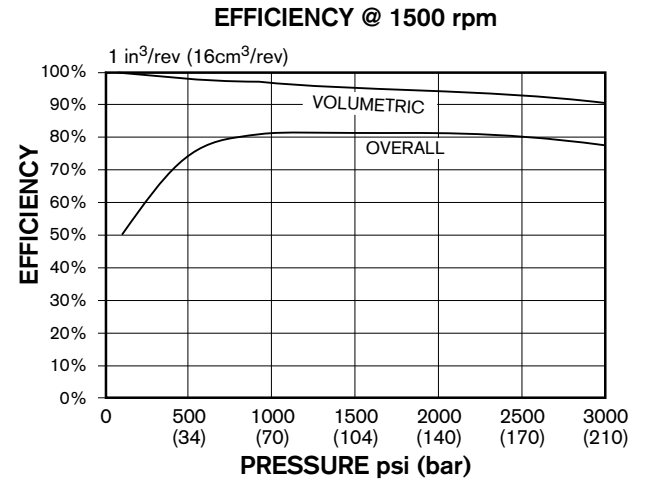
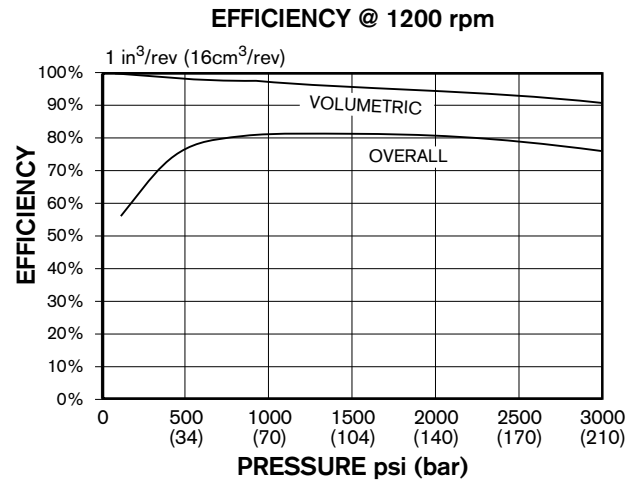
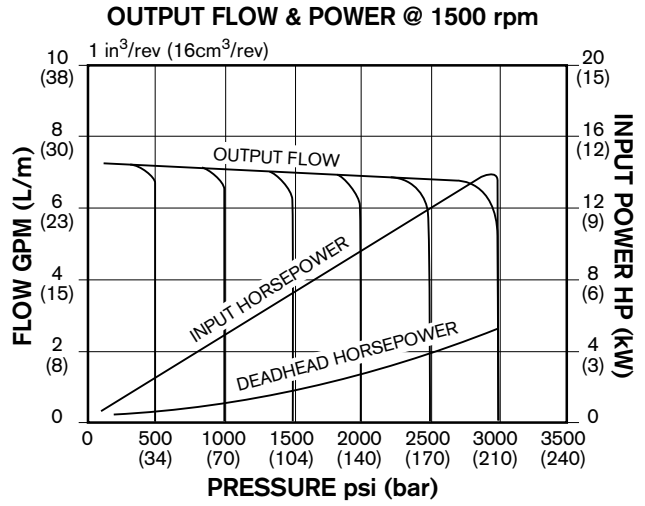
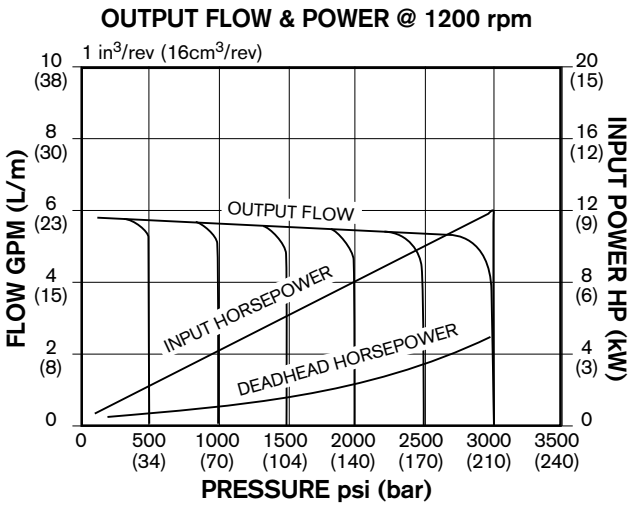

Sound pressure levels measured in a hemi-anoich chamber w/microphone placed 1 meter away at discrete locations. Sound pressure levels are spacially and time-weighted averaged.

Performance Characteristics - VPV 16 to 3000 PSI (210 Bar) (continued)

Data plotted: with oil at 120°F (49°C) Viscosity at 120° = 140 SUS (29.6 cSt)

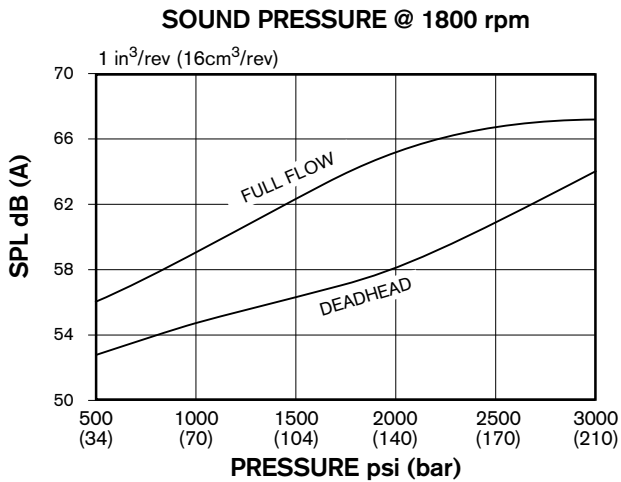
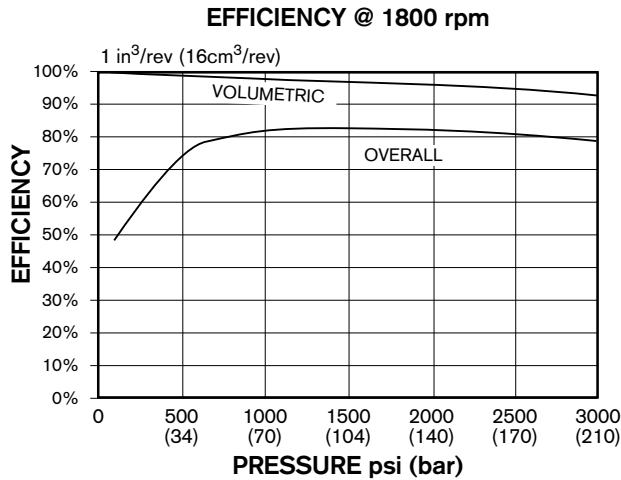
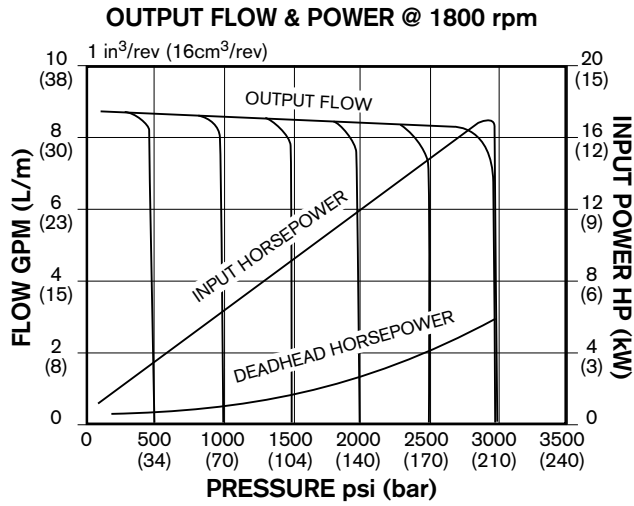

Sound pressure levels measured in a hemi-anoich chamber w/microphone placed 1 meter away at discrete locations. Sound pressure levels are spacially and time-weighted averaged.

Performance Characteristics - VPV 25 to 3000 PSI (210 Bar)

Data plotted: with oil at 120°F (49°C) Viscosity at 120° = 140 SUS (29.6 cSt)

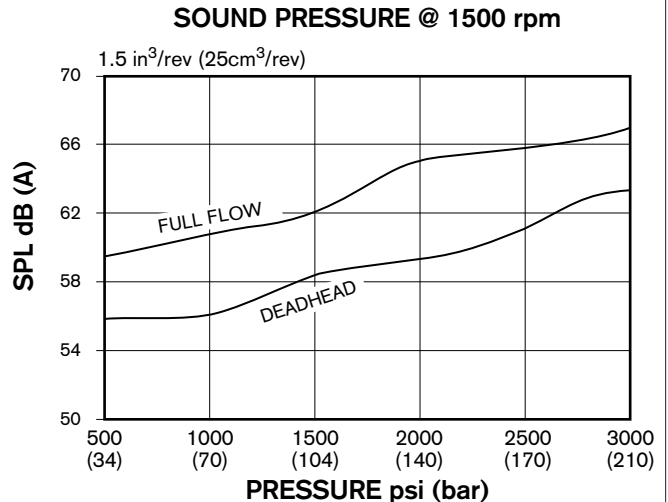
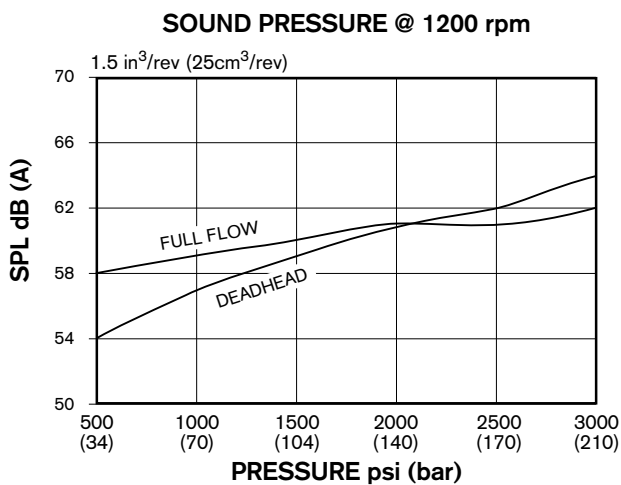
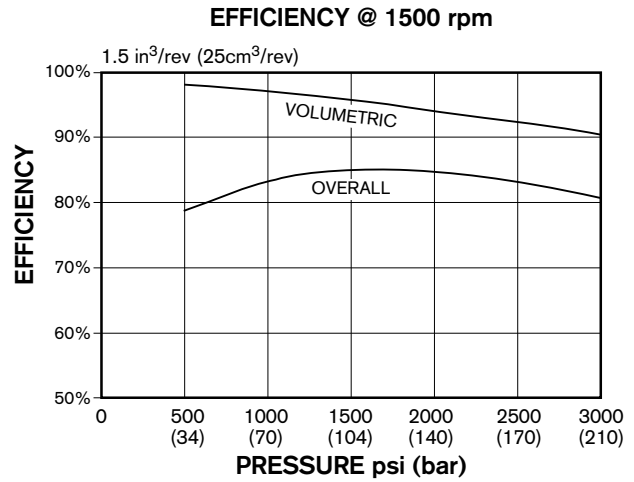
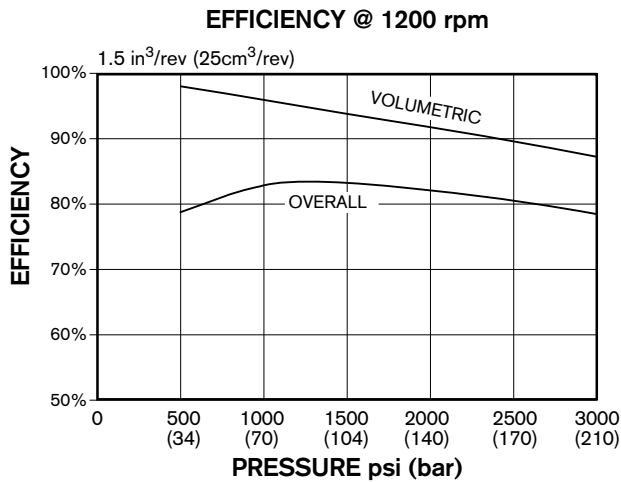
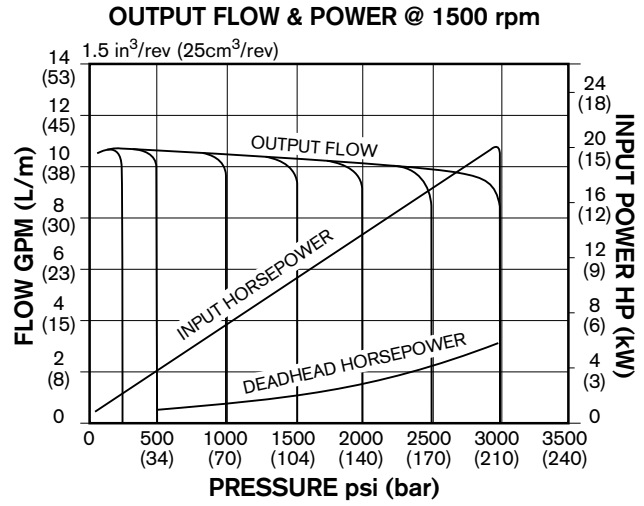
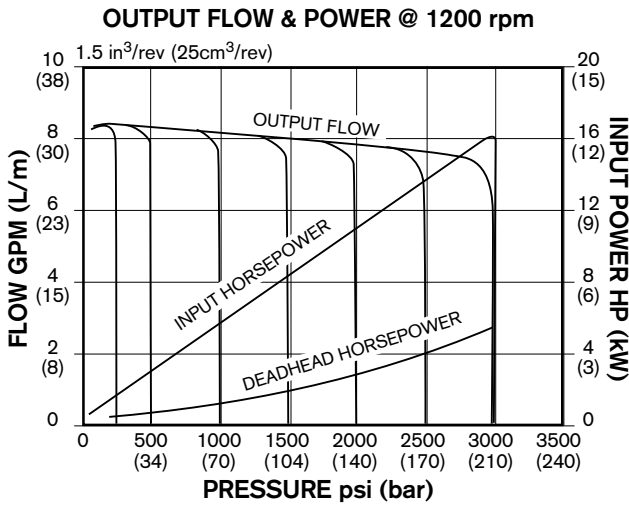

Sound pressure levels measured in a hemi-anoich chamber w/microphone placed 1 meter away at discrete locations.
 Sound pressure levels are spacially and time-weighted averaged.

Performance Characteristics - VPV 25 to 3000 PSI (210 Bar) (continued)

Data plotted: with oil at 120°F (49°C) Viscosity at 120° = 140 SUS (29.6 cSt)

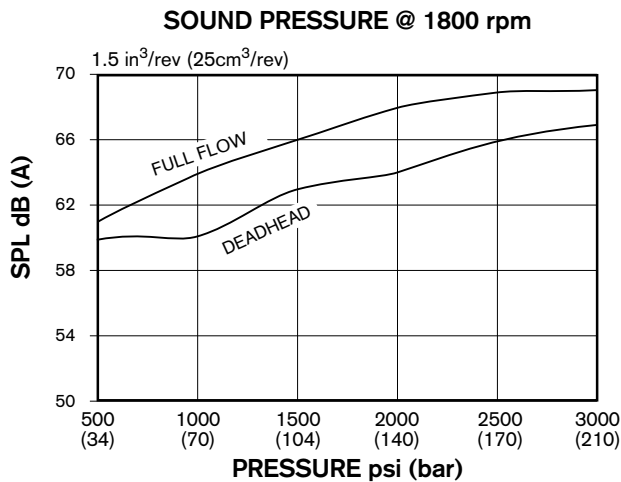
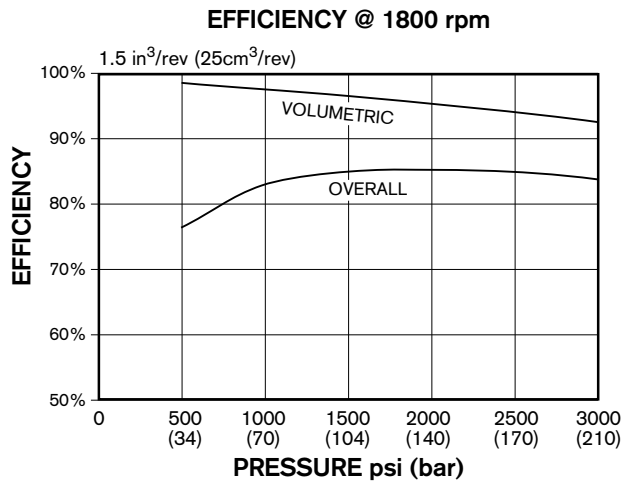
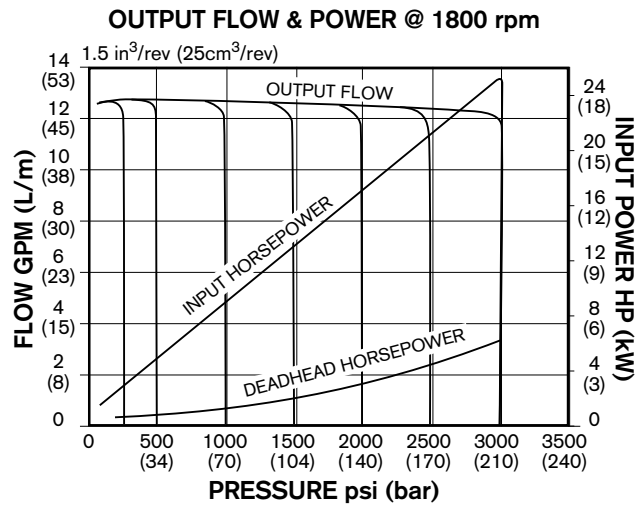

Sound pressure levels measured in a hemi-anoich chamber w/microphone placed 1 meter away at discrete locations. Sound pressure levels are spacially and time-weighted averaged.

Performance Characteristics - VPV 32 to 3000 PSI (210 Bar)

Data plotted: with oil at 120°F (49°C) Viscosity at 120° = 140 SUS (29.6 cSt)

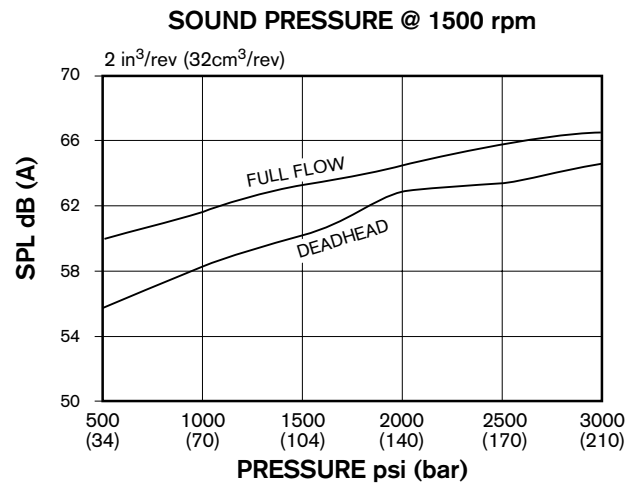
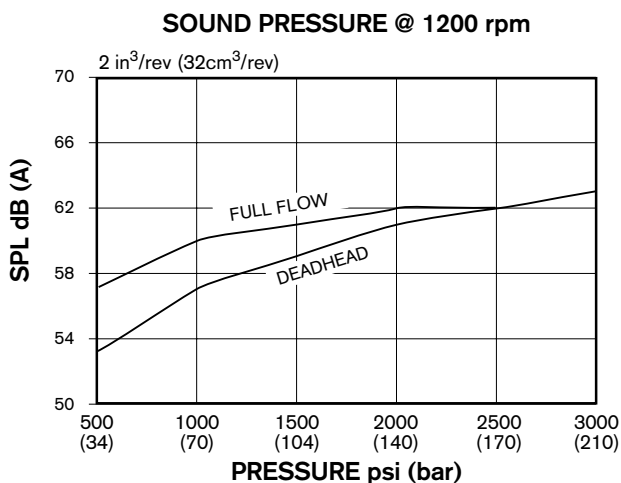
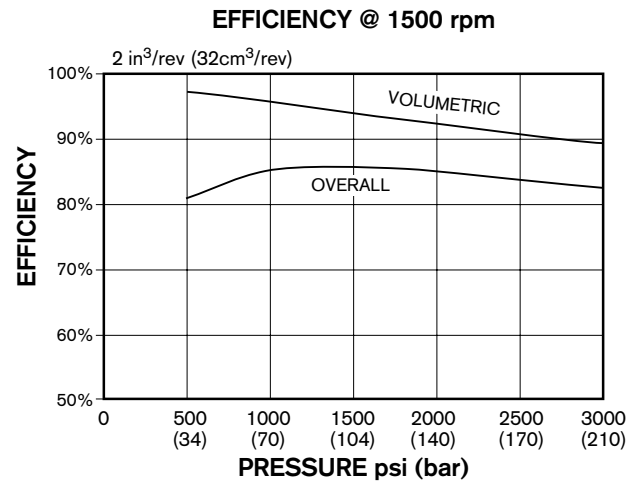
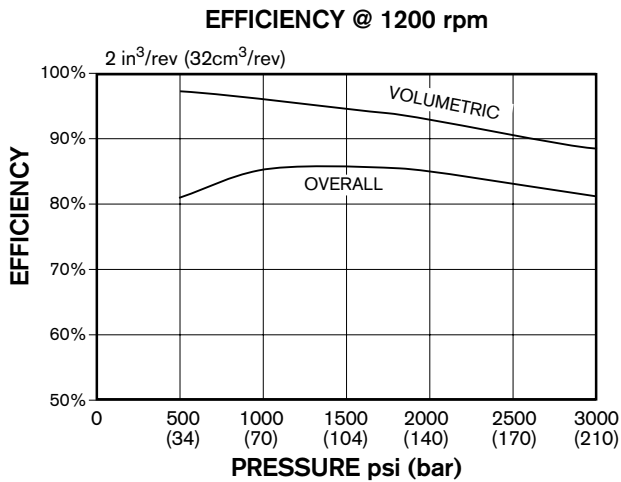
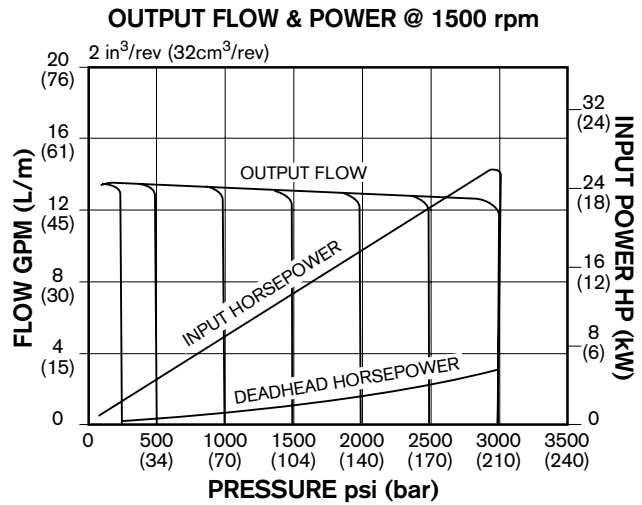
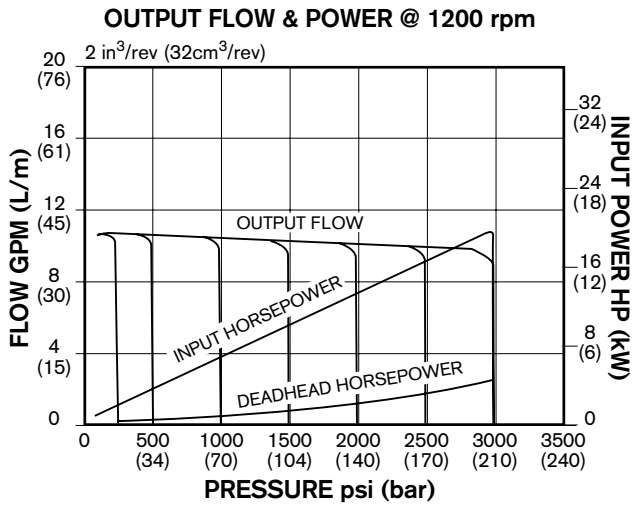

Sound pressure levels measured in a hemi-anoic chamber w/microphone placed 1 meter away at discrete locations.
 Sound pressure levels are spacially and time-weighted averaged.

Performance Characteristics - VPV 32 to 3000 PSI (210 Bar) (continued)

Data plotted: with oil at 120°F (49°C) Viscosity at 120° = 140 SUS (29.6 cSt)

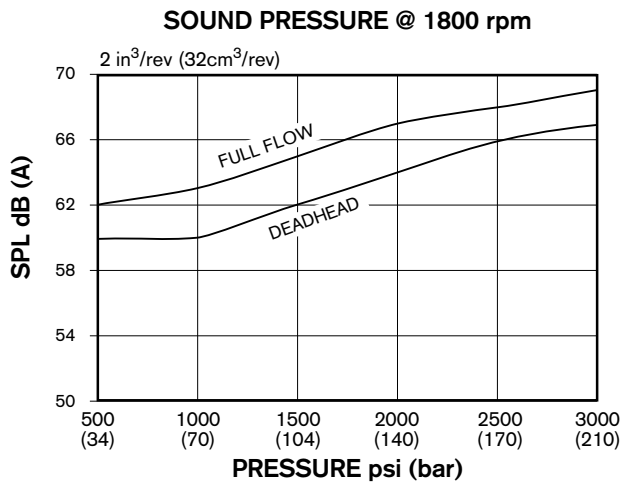
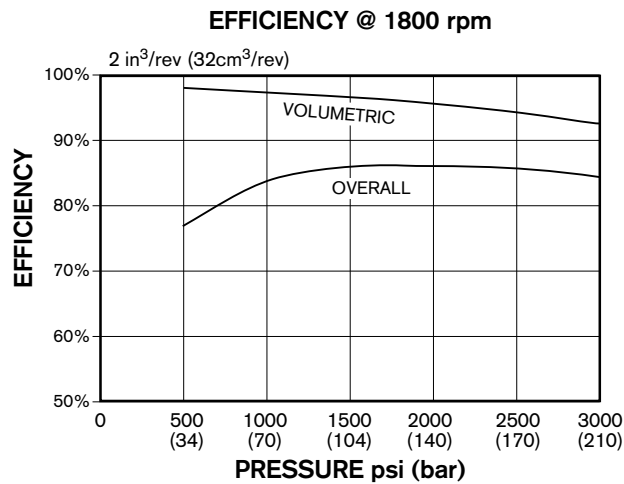
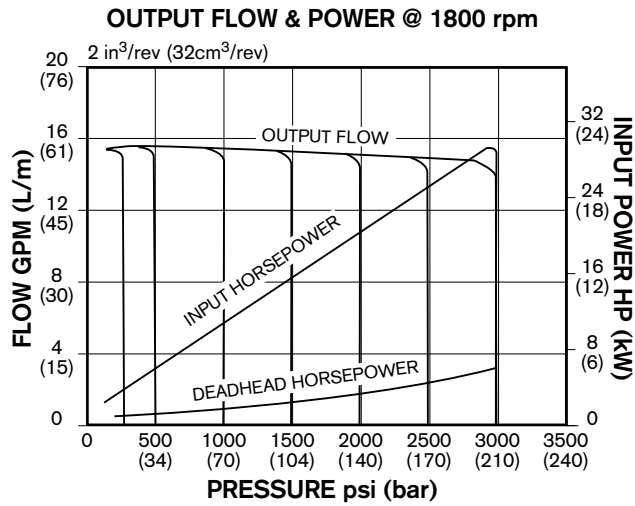

Sound pressure levels measured in a hemi-anechoic chamber w/microphone placed 1 meter away at discrete locations. Sound pressure levels are spacially and time-weighted averaged.

Performance Characteristics - VPV 45 to 3000 PSI (210 Bar)

Data plotted: with oil at 120°F (49°C) Viscosity at 120° = 140 SUS (29.6 cSt)

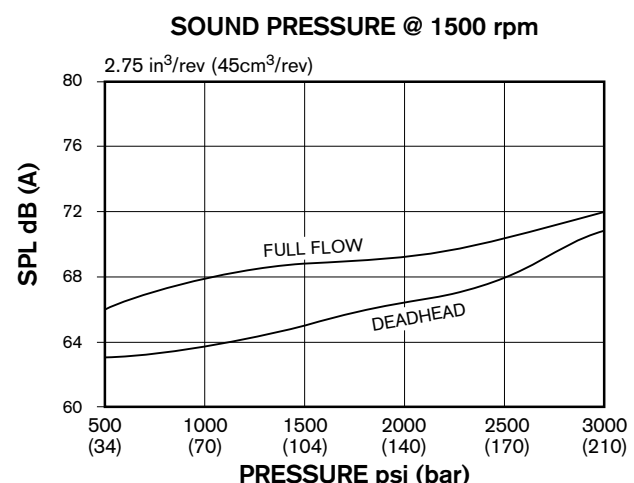
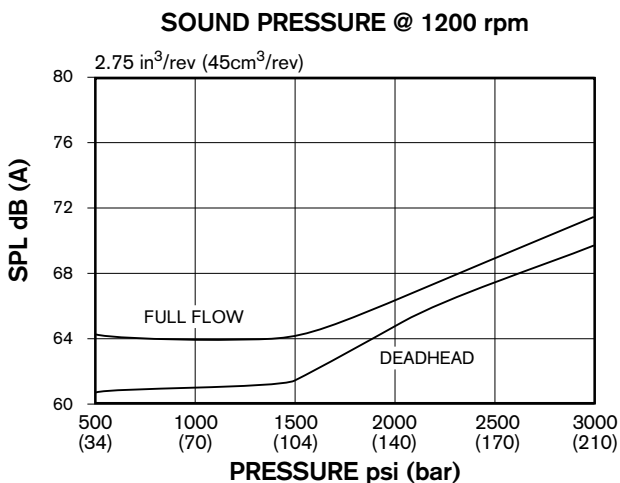
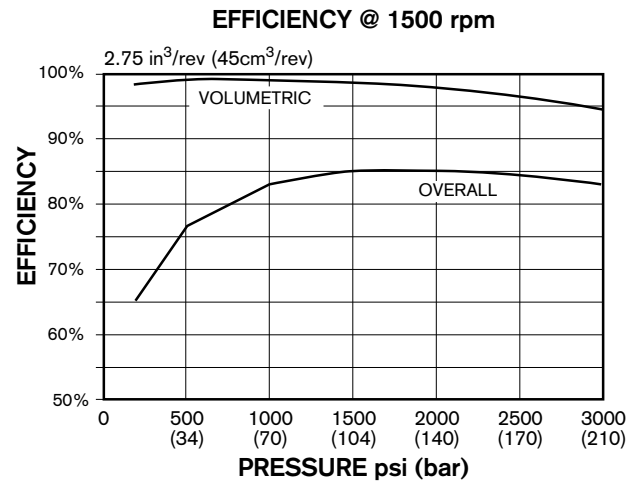
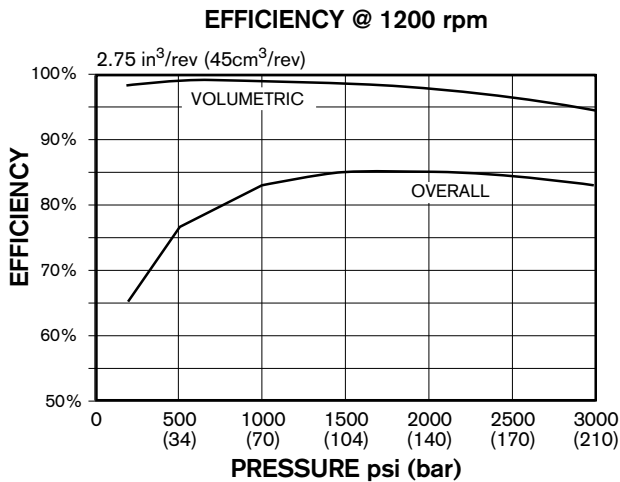
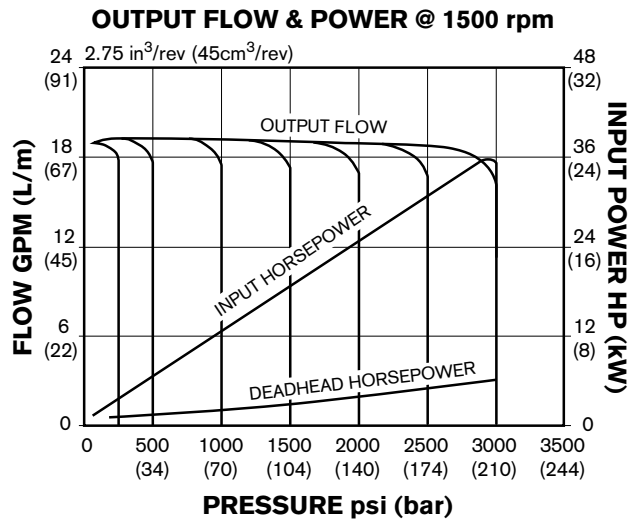
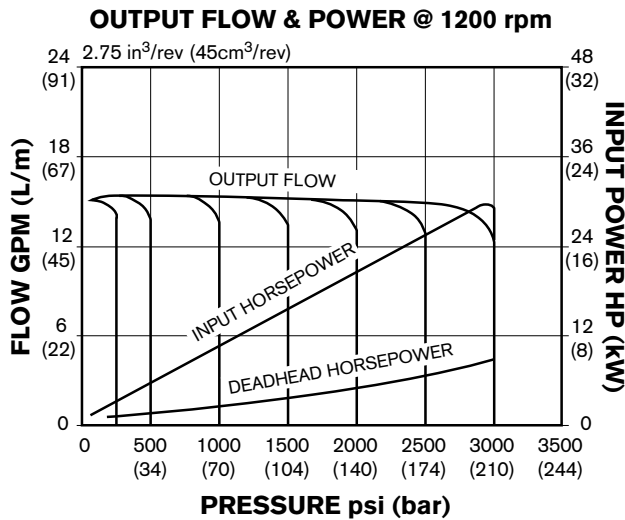

Sound pressure levels measured in a hemi-anoic chamber w/microphone placed 1 meter away at discrete locations.
 Sound pressure levels are spacially and time-weighted averaged.

Performance Characteristics - VPV 45 to 3000 PSI (210 Bar) (continued)

Data plotted: with oil at 120°F (49°C) Viscosity at 120° = 140 SUS (29.6 cSt)

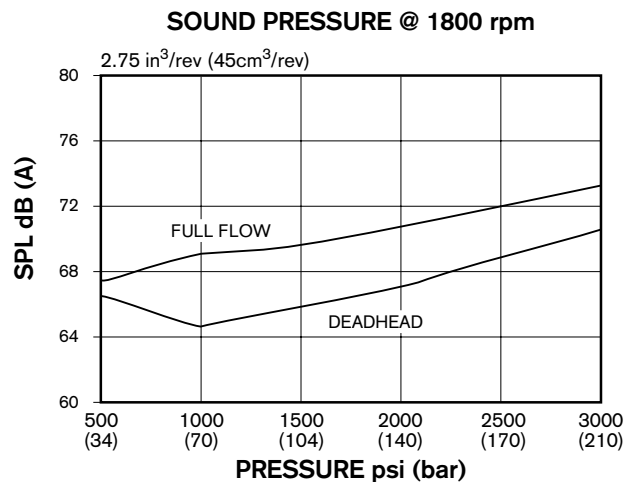
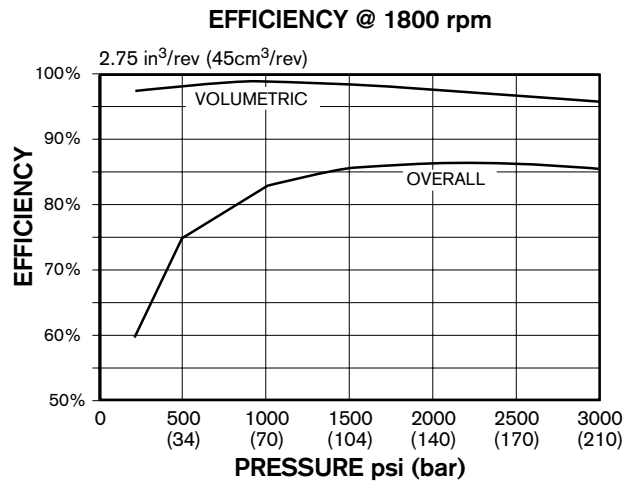
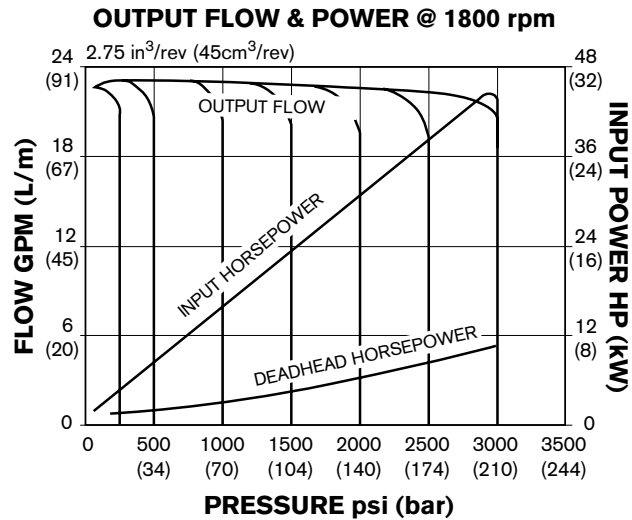

Sound pressure levels measured in a hemi-anoich chamber w/microphone placed 1 meter away at discrete locations. Sound pressure levels are spacially and time-weighted averaged.

Performance Characteristics - VPV 63 to 3000 PSI (210 Bar)

Data plotted: with oil at 120°F (49°C) Viscosity at 120° = 140 SUS (29.6 cSt)

OUTPUT FLOW & POWER @ 1200 rpm

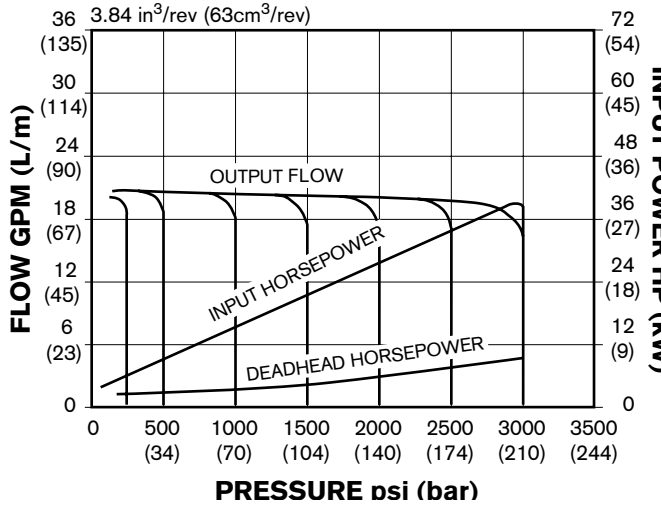

OUTPUT FLOW & POWER @ 1500 rpm

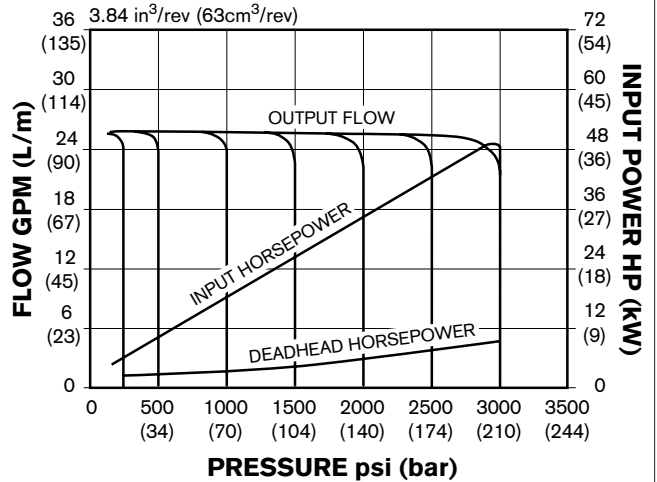

EFFICIENCY @ 1200 rpm

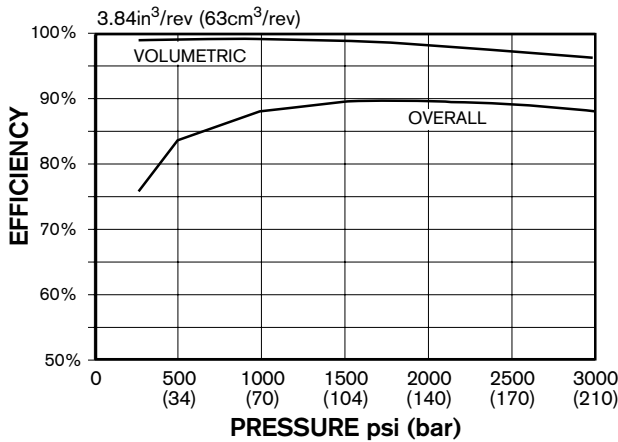

EFFICIENCY @ 1500 rpm

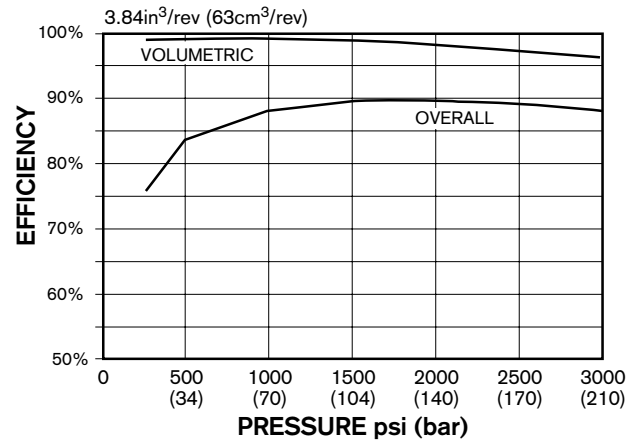

SOUND PRESSURE @ 1200 rpm

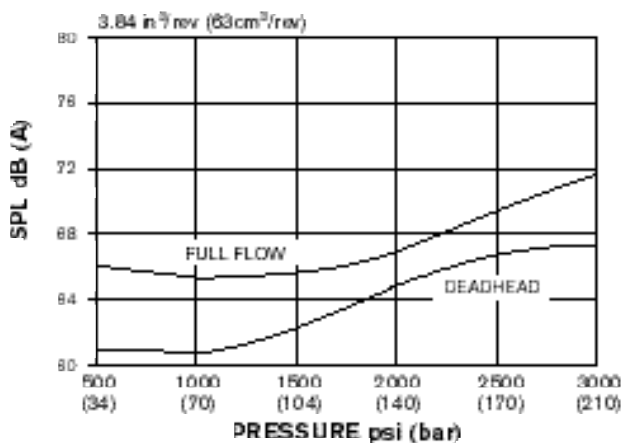

SOUND PRESSURE @ 1500 rpm

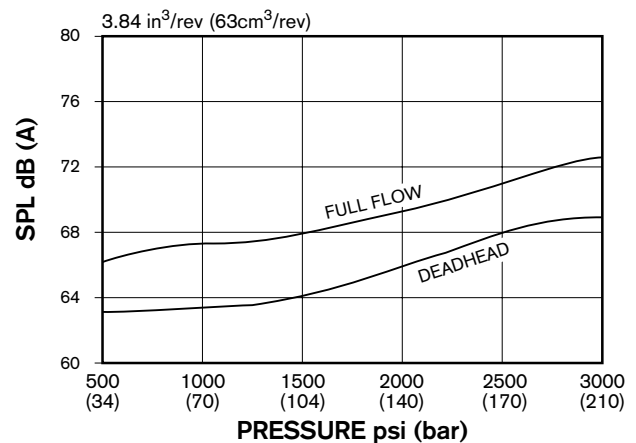

Sound pressure levels measured in a hemi-anochoic chamber w/microphone placed 1 meter away at discrete locations. Sound pressure levels are spatially and time-weighted averaged.

Performance Characteristics - VPV 63 to 3000 PSI (210 Bar) (continued)

Data plotted: with oil at 120°F (49°C) Viscosity at 120° = 140 SUS (29.6 cSt)

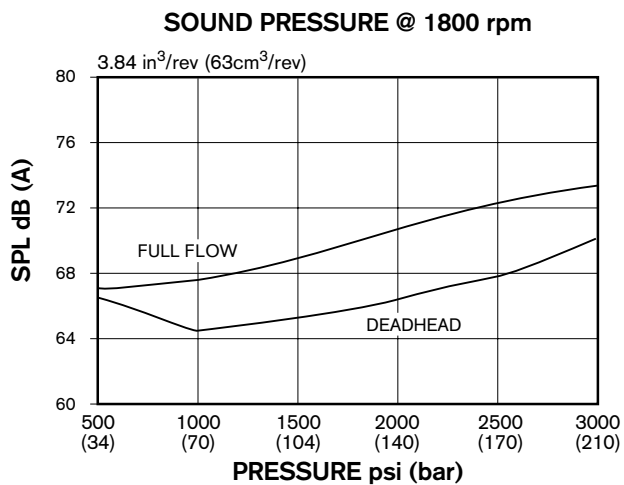
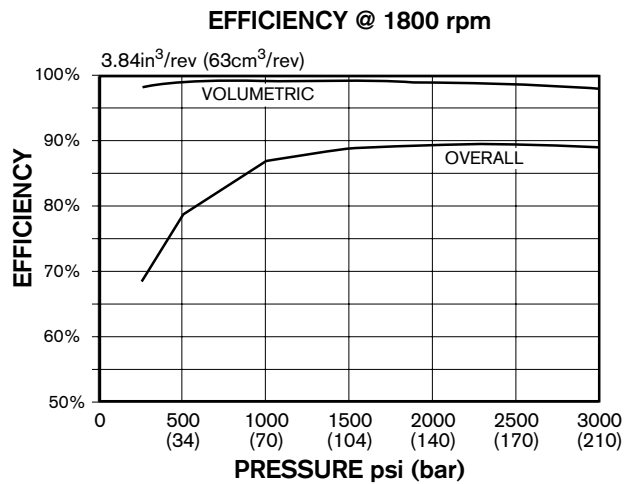
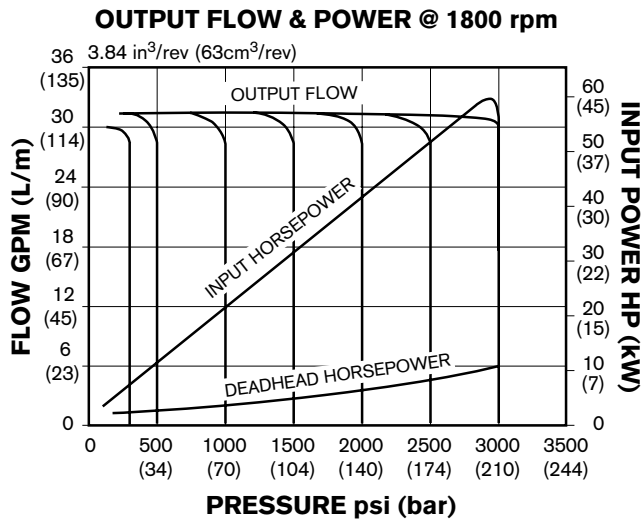

Sound pressure levels measured in a hemi-anoic chamber w/microphone placed 1 meter away at discrete locations. Sound pressure levels are spacially and time-weighted averaged.

Performance Characteristics - VPV 80 to 3000 PSI (210 Bar)

Data plotted: with oil at 120°F (49°C) Viscosity at 120° = 140 SUS (29.6 cSt)

OUTPUT FLOW & POWER @ 1200 rpm

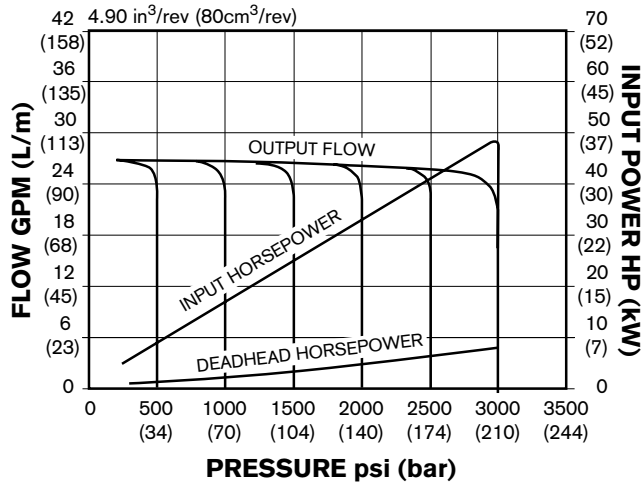

OUTPUT FLOW & POWER @ 1500 rpm

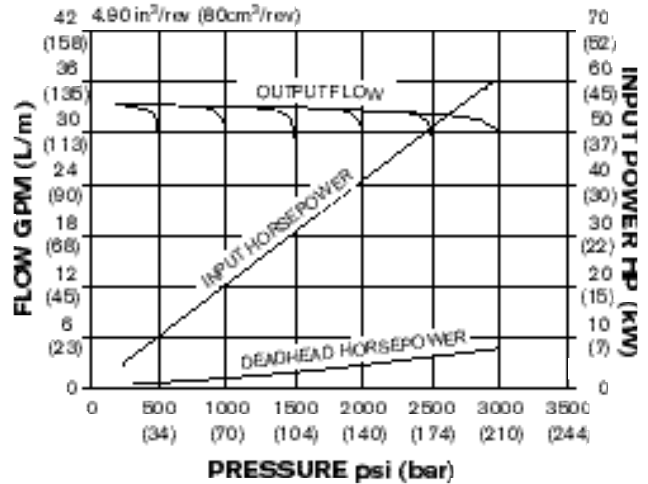

EFFICIENCY @ 1200 rpm

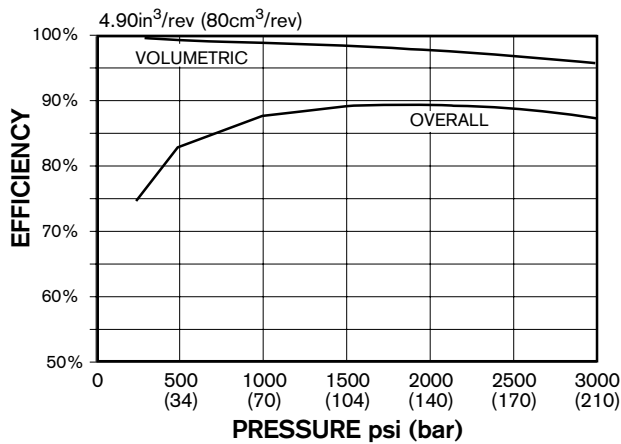

EFFICIENCY @ 1500 rpm

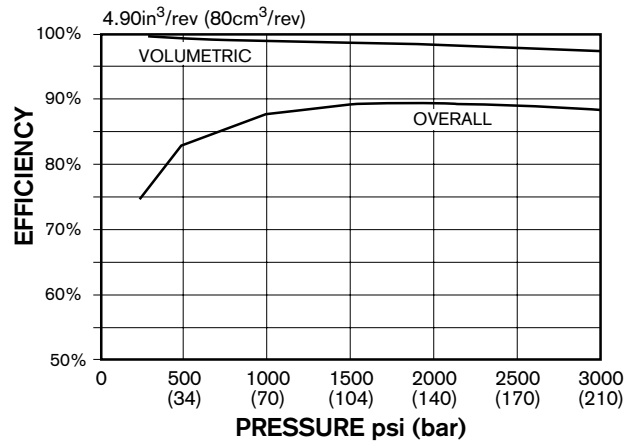

SOUND PRESSURE @ 1200 rpm

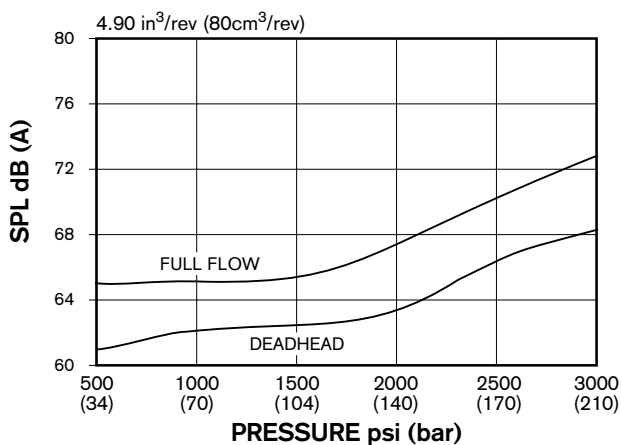

SOUND PRESSURE @ 1500 rpm

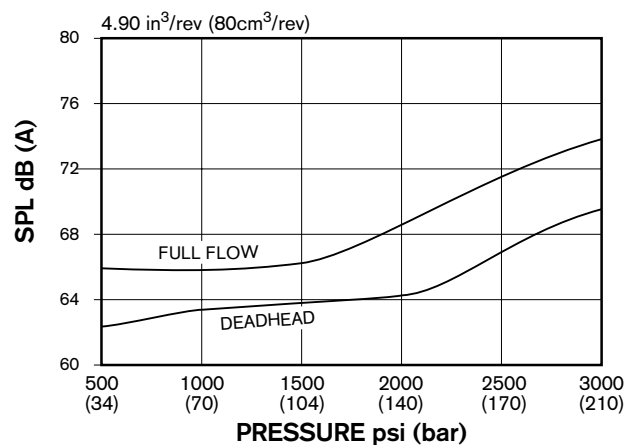

Sound pressure levels measured in a hemi-anoich chamber w/microphone placed 1 meter away at discrete locations. Sound pressure levels are spacially and time-weighted averaged.

Performance Characteristics - VPV 80 to 3000 PSI (210 Bar) (continued)

Data plotted: with oil at 120°F (49°C) Viscosity at 120° = 140 SUS (29.6 cSt)

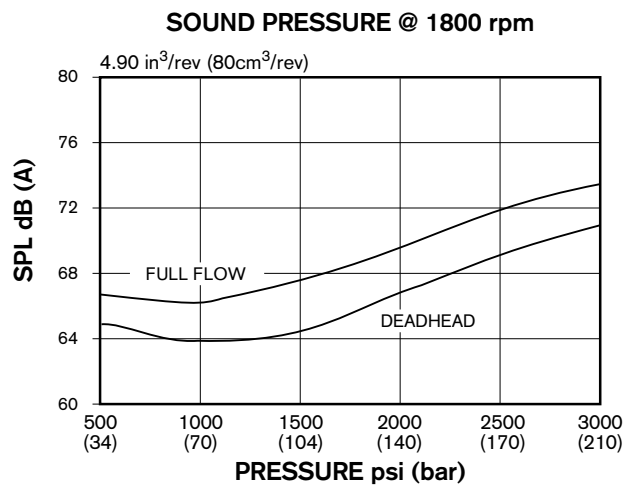
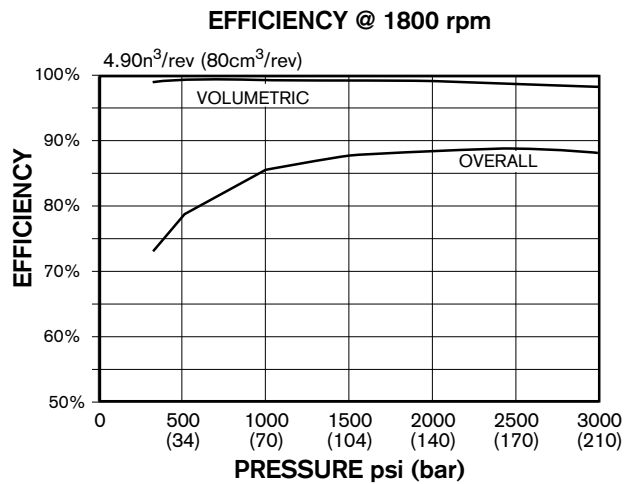
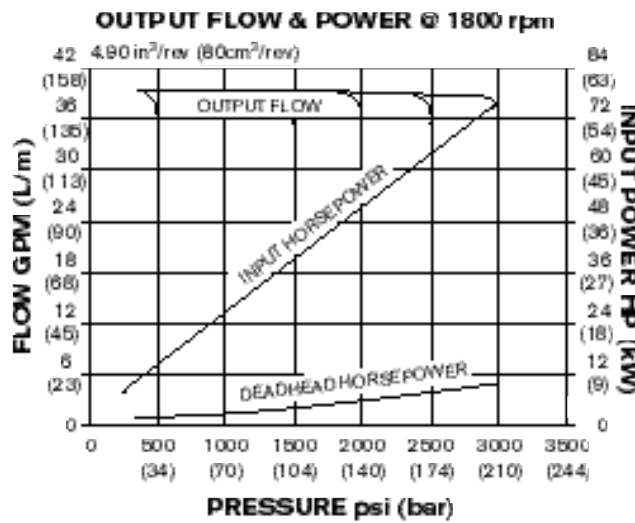

Sound pressure levels measured in a hemi-anoich chamber w/microphone placed 1 meter away at discrete locations. Sound pressure levels are spacially and time-weighted averaged.

Performance Characteristics - VPV 100 to 3000 PSI (210 Bar)

Data plotted: with oil at 120°F (49°C) Viscosity at 120° = 140 SUS (29.6 cSt)

OUTPUT FLOW & POWER @ 1200 rpm

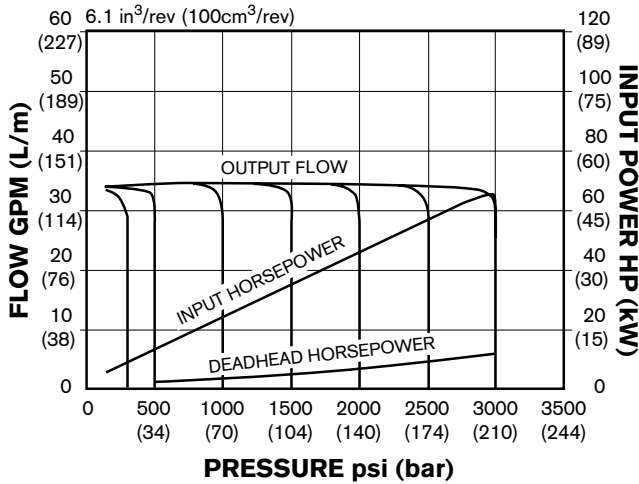

OUTPUT FLOW & POWER @ 1500 rpm

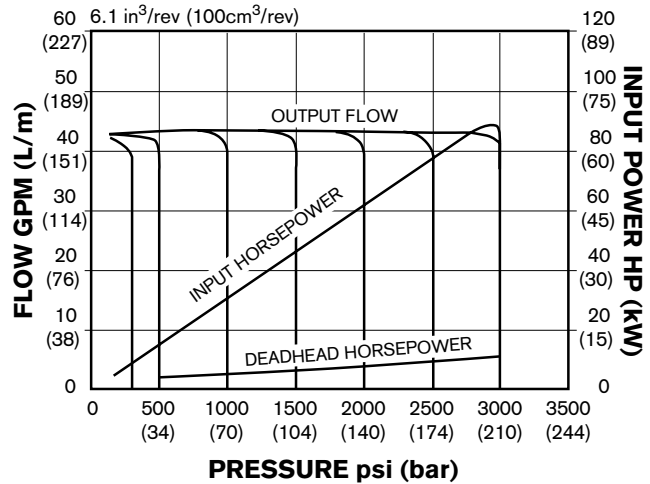

EFFICIENCY @ 1200 rpm

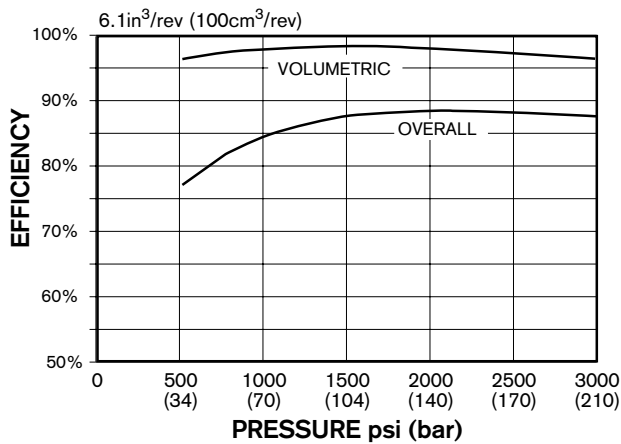

EFFICIENCY @ 1500 rpm

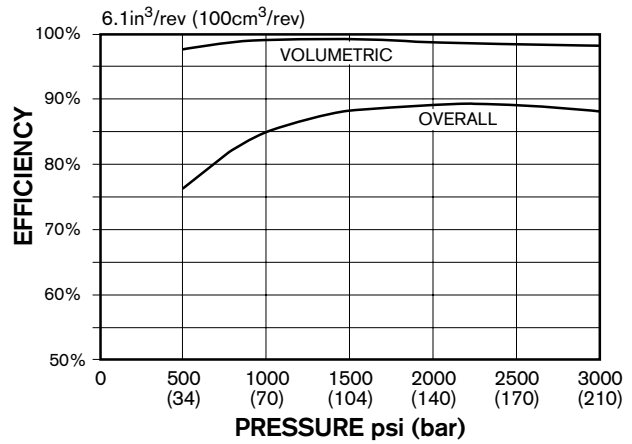

SOUND PRESSURE @ 1200 rpm

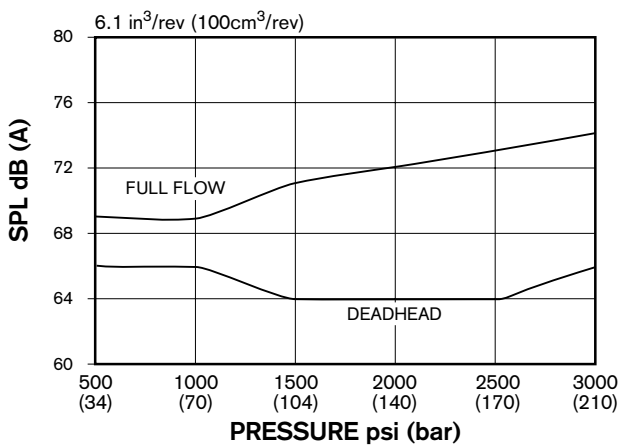

SOUND PRESSURE @ 1500 rpm

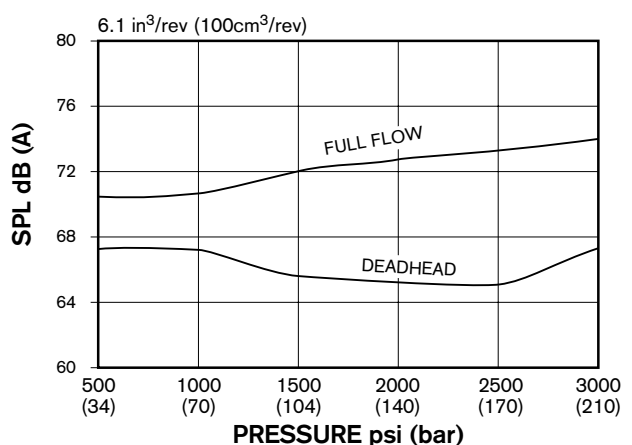

Sound pressure levels measured in a hemi-anoich chamber w/microphone placed 1 meter away at discrete locations. Sound pressure levels are spacially and time-weighted averaged.

Performance Characteristics - VPV 100 to 3000 PSI (210 Bar) (continued)

Data plotted: with oil at 120°F (49°C) Viscosity at 120° = 140 SUS (29.6 cSt)

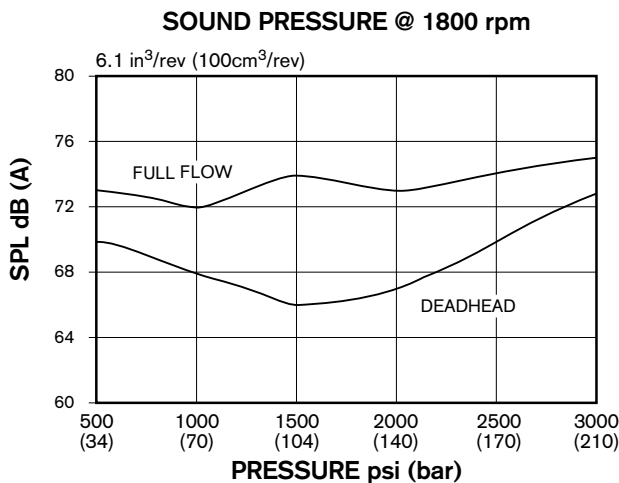
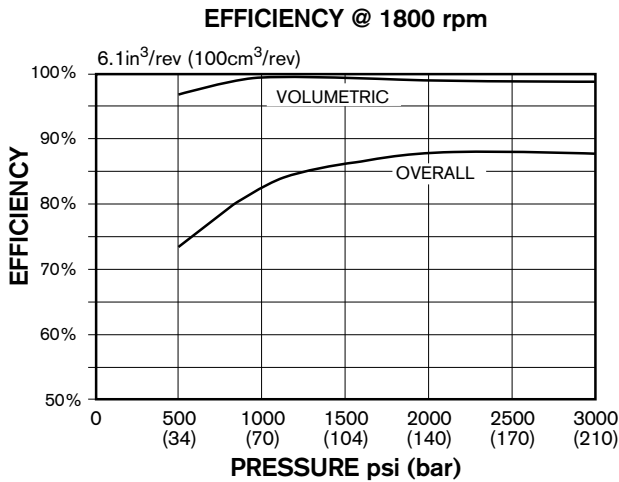
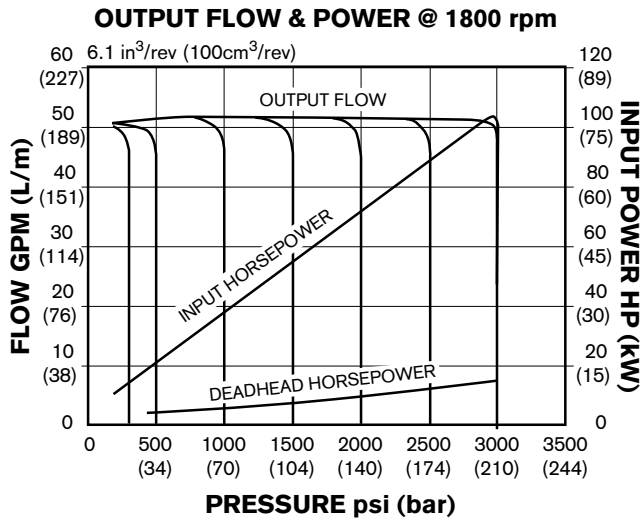

Sound pressure levels measured in a hemi-anoich chamber w/microphone placed 1 meter away at discrete locations. Sound pressure levels are spacially and time-weighted averaged.

Performance Characteristics - VPV 130 to 3000 PSI (210 Bar)

Data plotted: with oil at 120°F (49°C) Viscosity at 120° = 140 SUS (29.6 cSt)

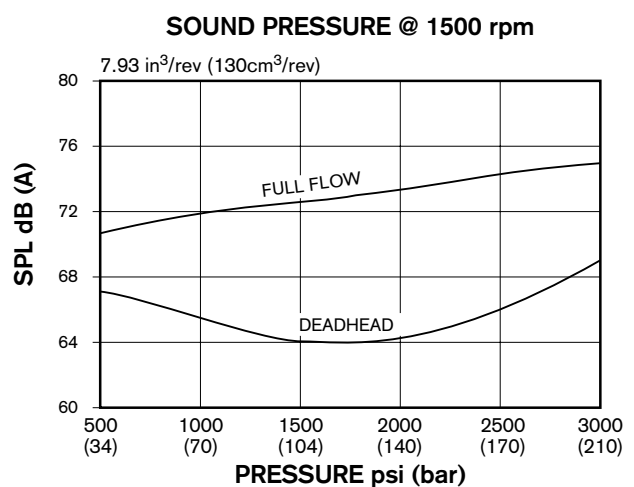
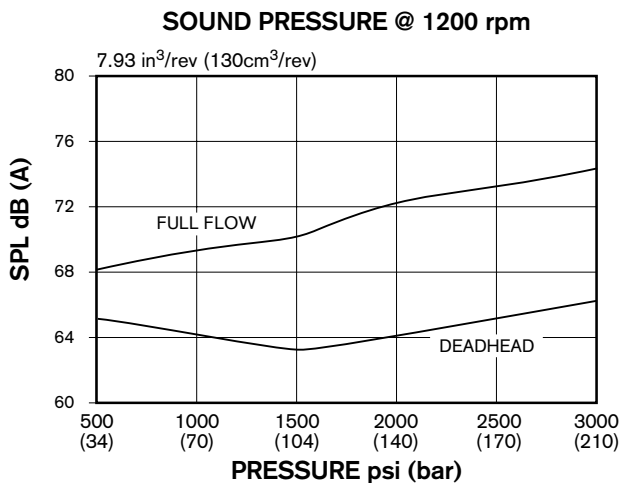
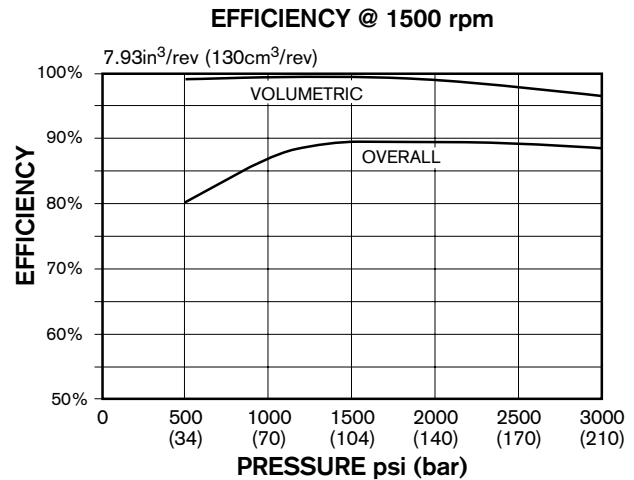
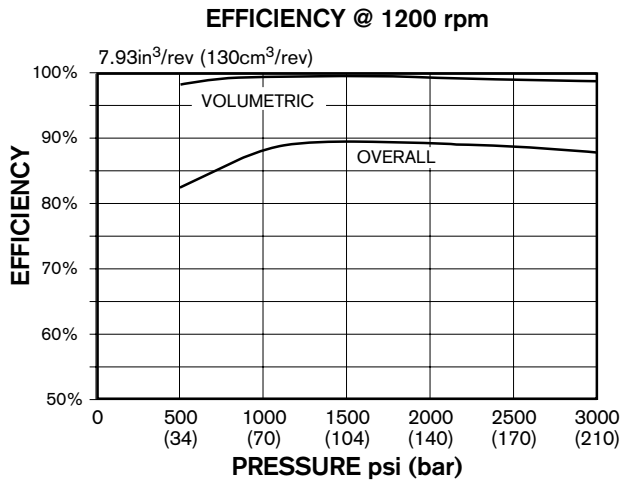
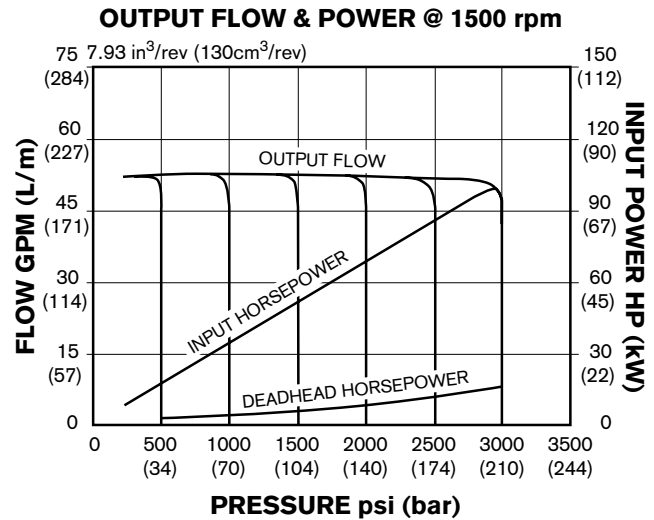
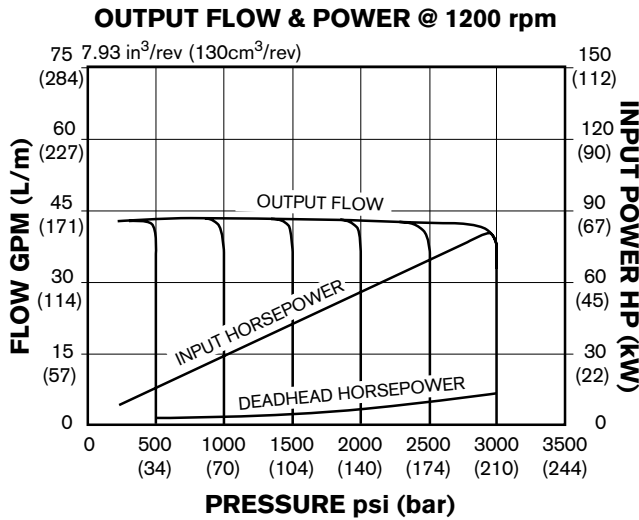

Sound pressure levels measured in a hemi-anoich chamber w/microphone placed 1 meter away at discrete locations.
 Sound pressure levels are spacially and time-weighted averaged.

Performance Characteristics - VPV 130 to 3000 PSI (210 Bar) (continued)

Data plotted: with oil at 120°F (49°C) Viscosity at 120° = 140 SUS (29.6 cSt)

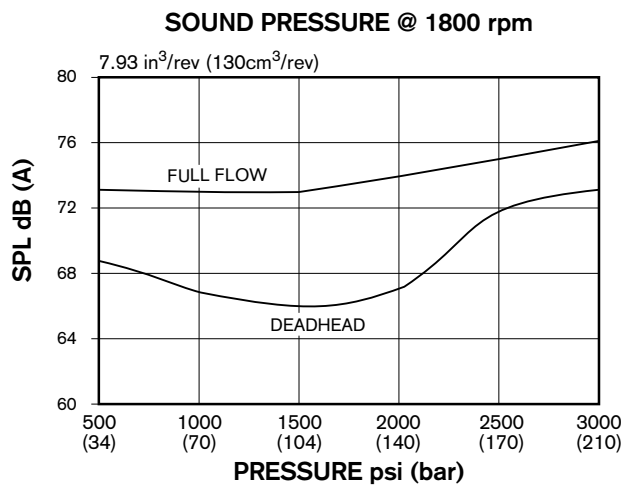
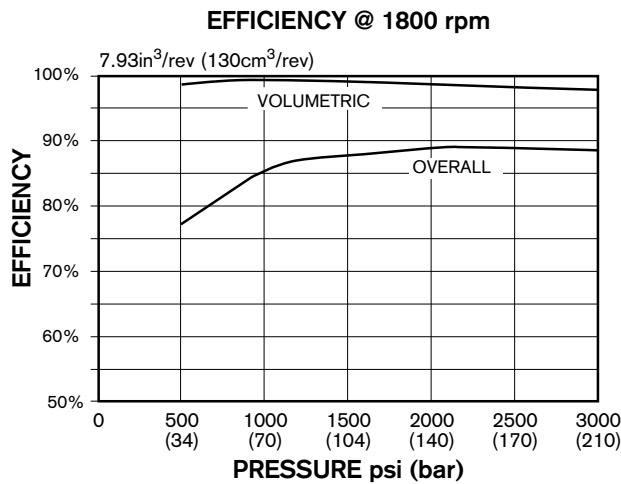
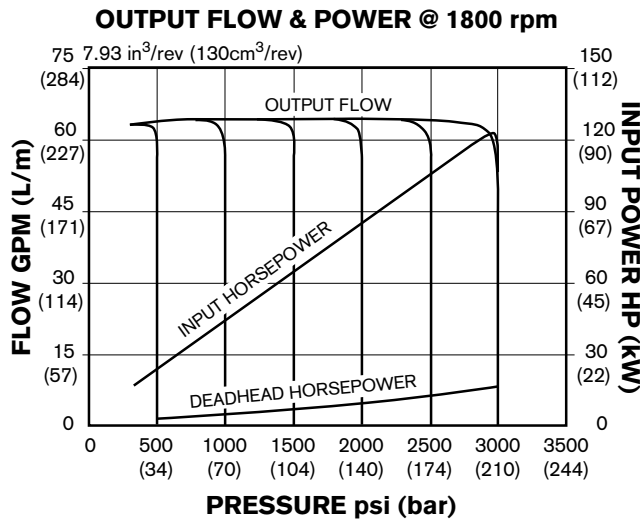

Sound pressure levels measured in a hemi-anechoic chamber w/microphone placed 1 meter away at discrete locations. Sound pressure levels are spacially and time-weighted averaged.

Performance Characteristics - VPV 164 to 3000 PSI (210 Bar)

Data plotted: with oil at 120°F (49°C) Viscosity at 120° = 140 SUS (29.6 cSt)

OUTPUT FLOW & POWER @ 1200 rpm

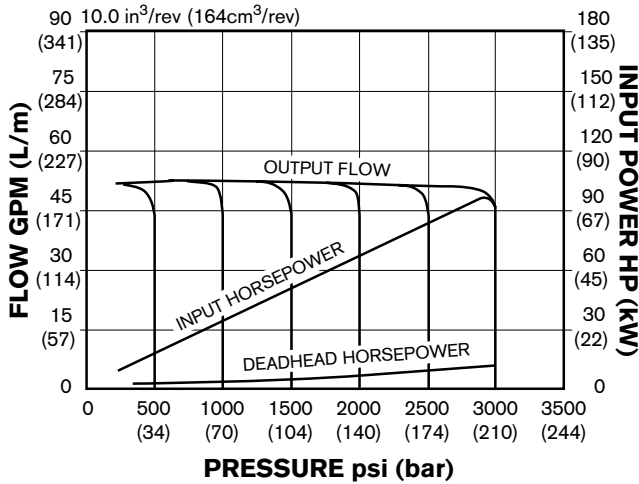

OUTPUT FLOW & POWER @ 1500 rpm

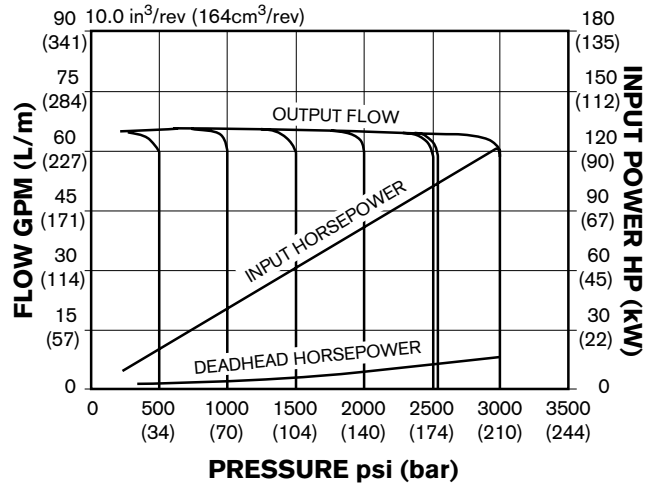

EFFICIENCY @ 1200 rpm

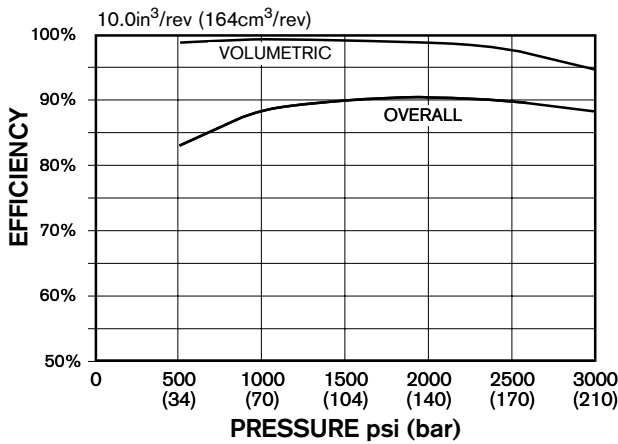

EFFICIENCY @ 1500 rpm

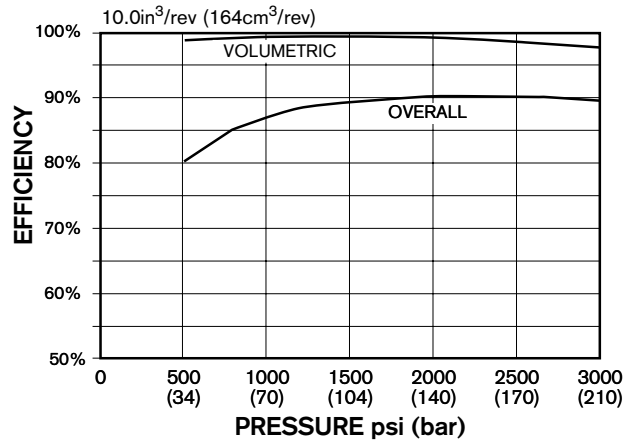

SOUND PRESSURE @ 1200 rpm

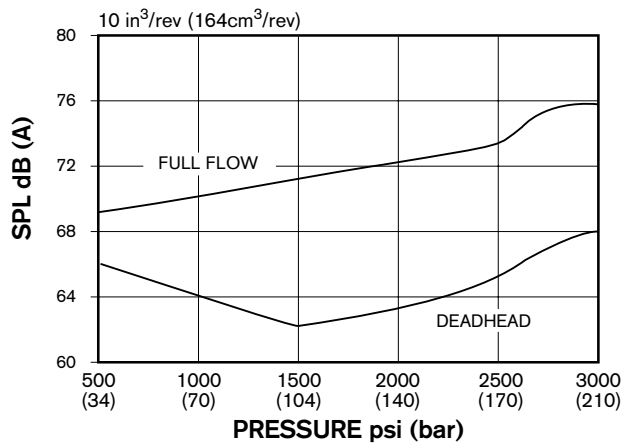

SOUND PRESSURE @ 1500 rpm

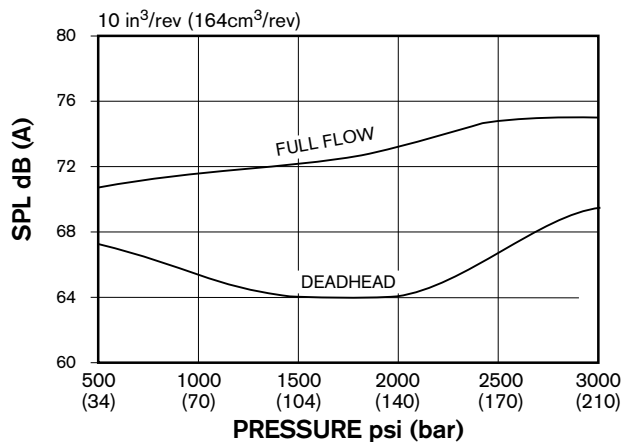

Sound pressure levels measured in a hemi-anechoic chamber w/microphone placed 1 meter away at discrete locations. Sound pressure levels are spatially and time-weighted averaged.

Performance Characteristics - VPV 164 to 3000 PSI (210 Bar) (continued)

Data plotted: with oil at 120°F (49°C) Viscosity at 120° = 140 SUS (29.6 cSt)

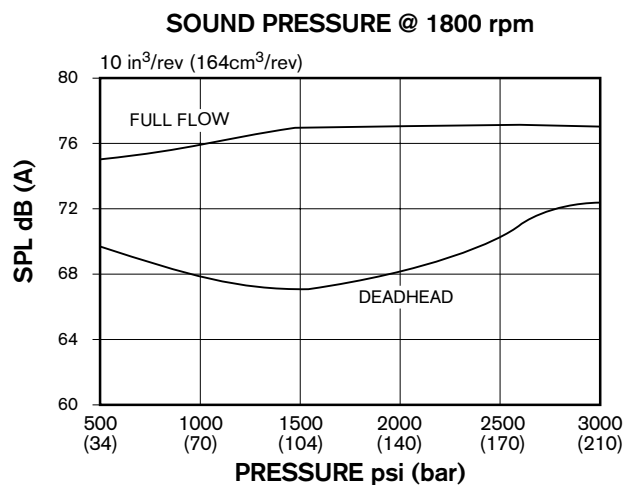
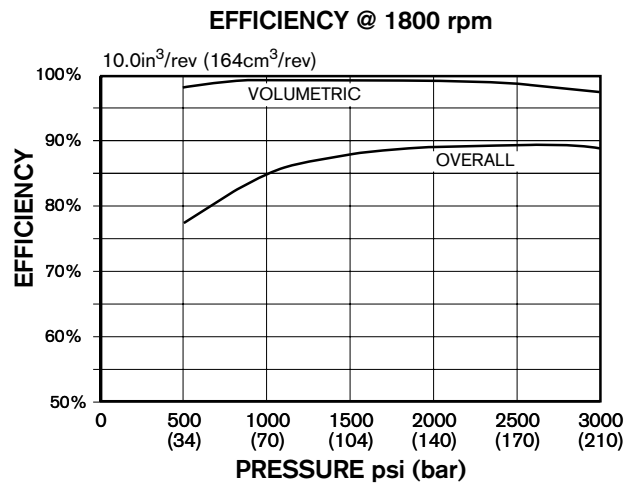
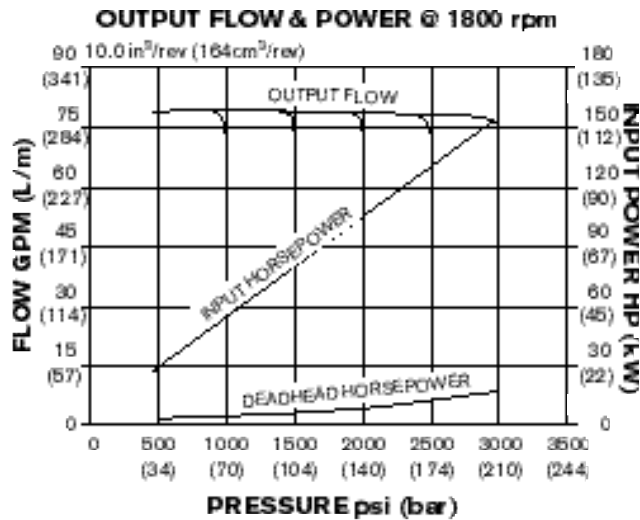

Sound pressure levels measured in a hemi-anoich chamber w/microphone placed 1 meter away at discrete locations. Sound pressure levels are spacially and time-weighted averaged.

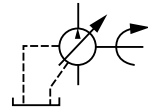

VPV 16, Single pump, S.A.E. 'A' flange, RH rotation

Inches (millimeters)

30° Involute Spline Data

Flat root side fit	Class 5
Pitch	16/32
Pressure angle	30°
Number of teeth	9
Base Dia.	0.487193 in. ref.
Form Dia.	0.504 in. ref.
Major Dia.	0.625 +0.000 in. ref. -0.022

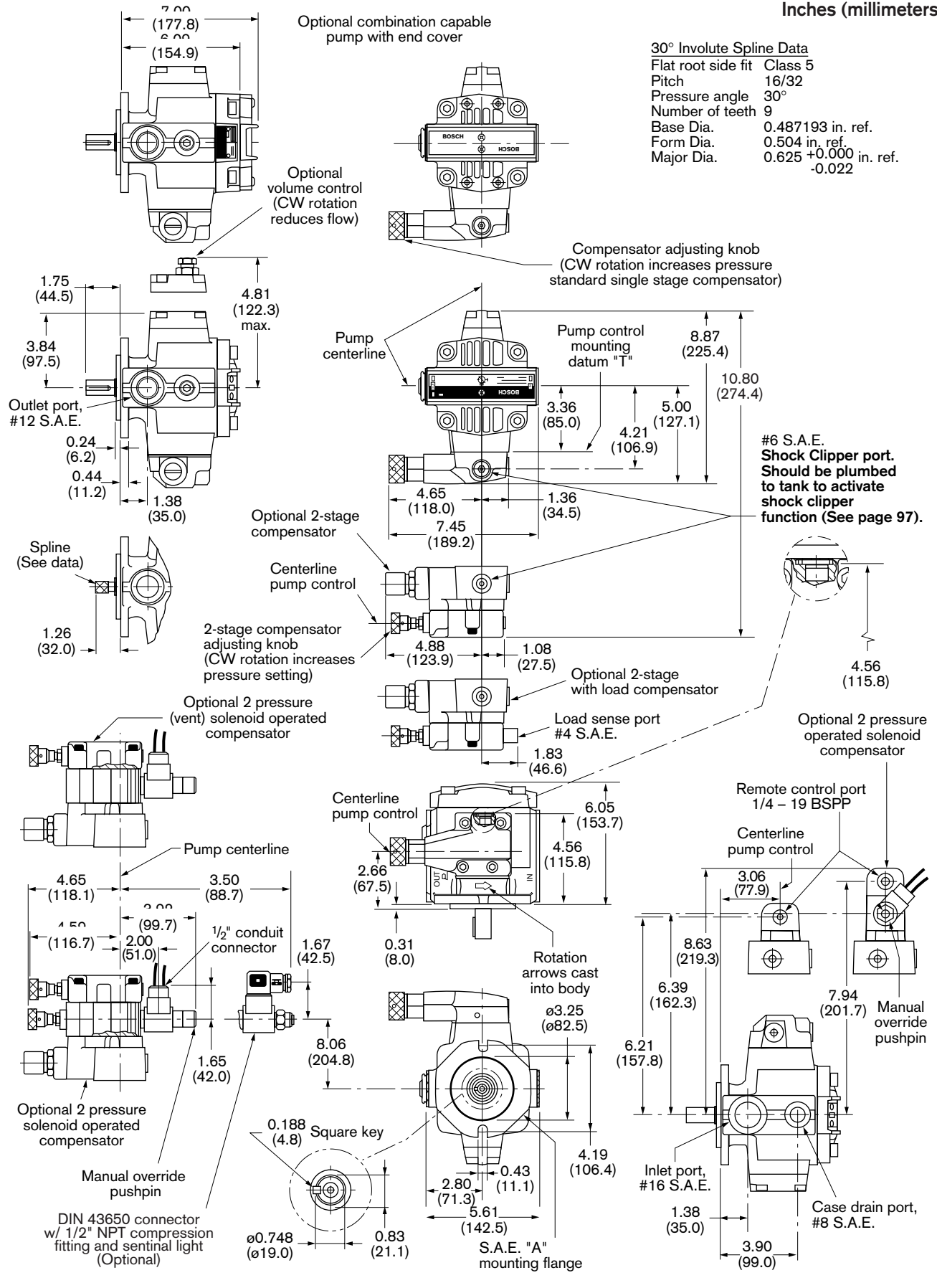

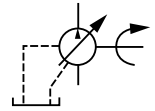

VPV 16 Single pump, Metric flange, RH rotation

Inches (millimeters)

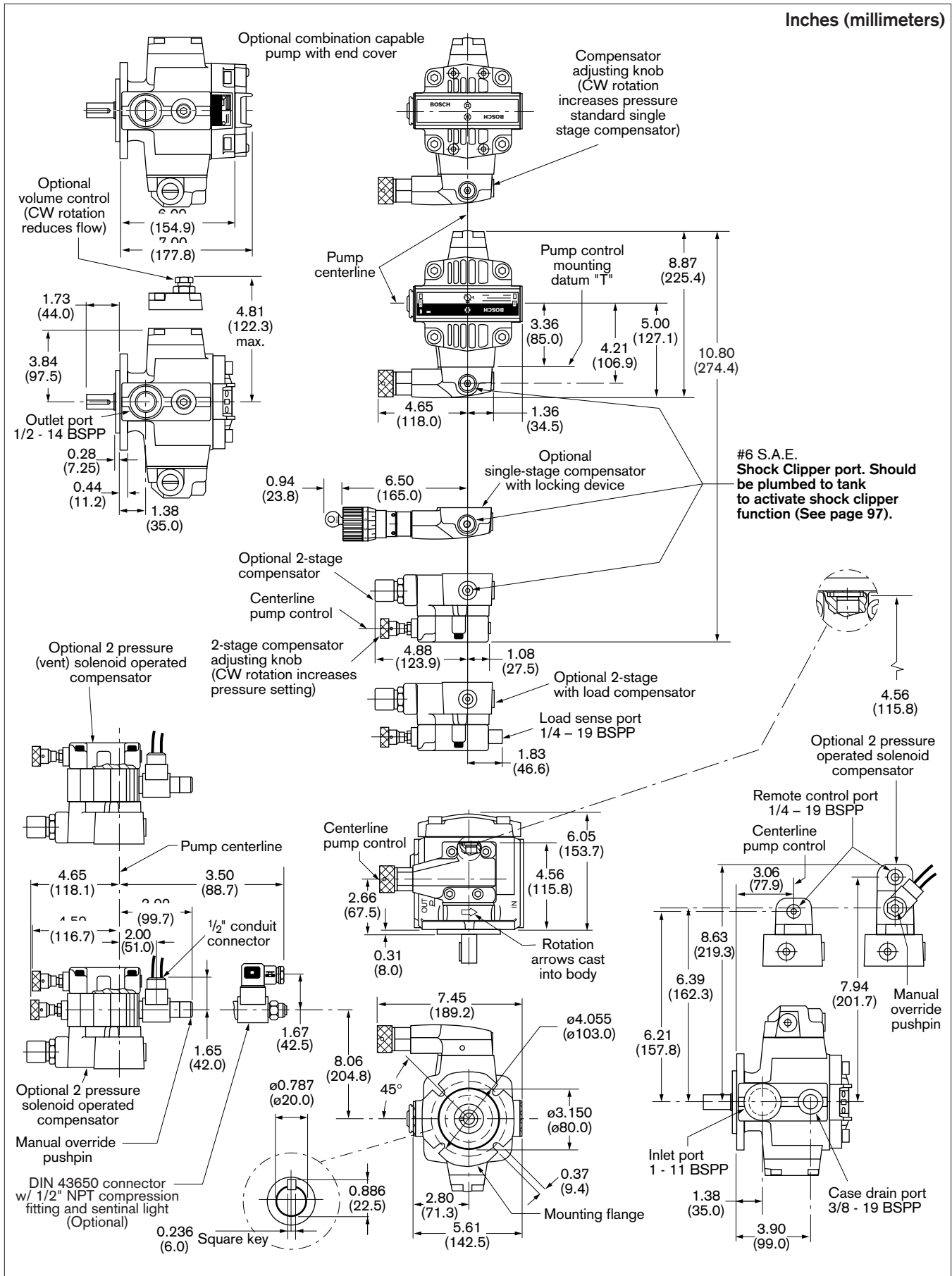

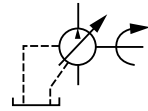

VPV 25/32, Single pump, S.A.E. 'B' flange, RH rotation

Inches (millimeters)

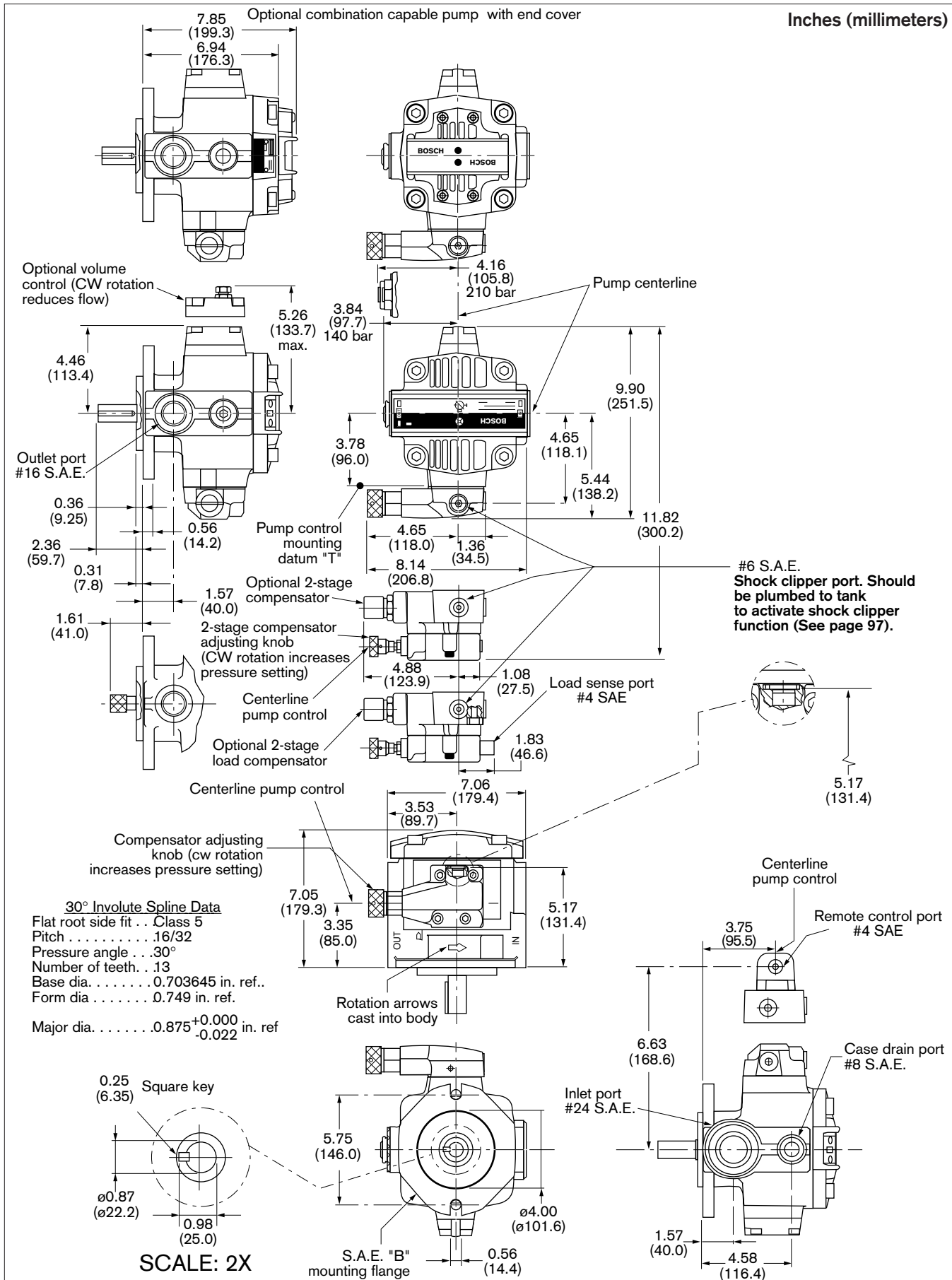

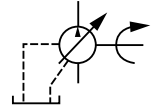

VPV 25/32, Single pump, Metric flange, RH rotation

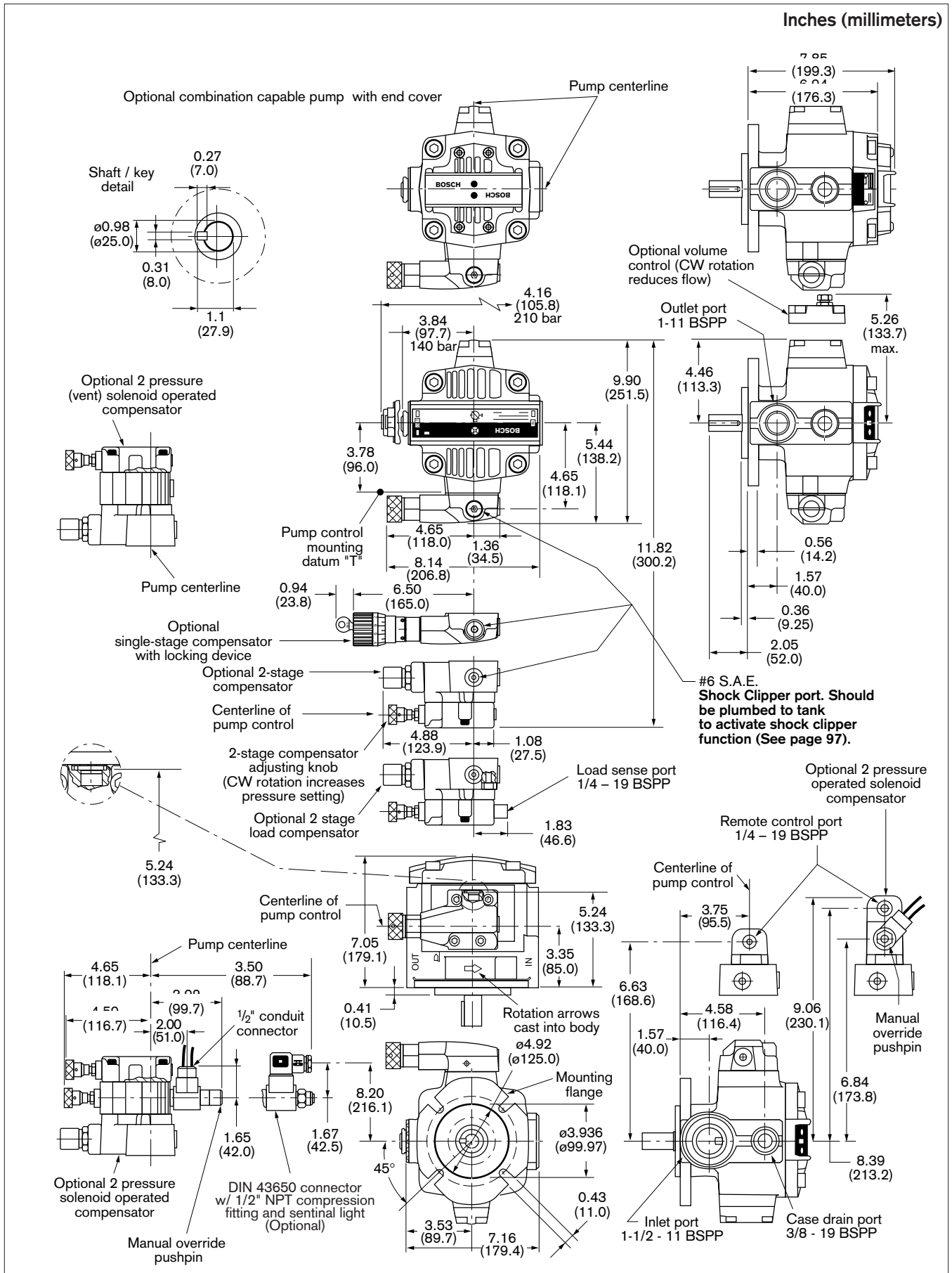

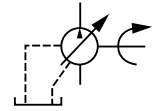

VPV 25/32, Single pump, S.A.E. 'B' flange, RH rotation

Inches (millimeters)

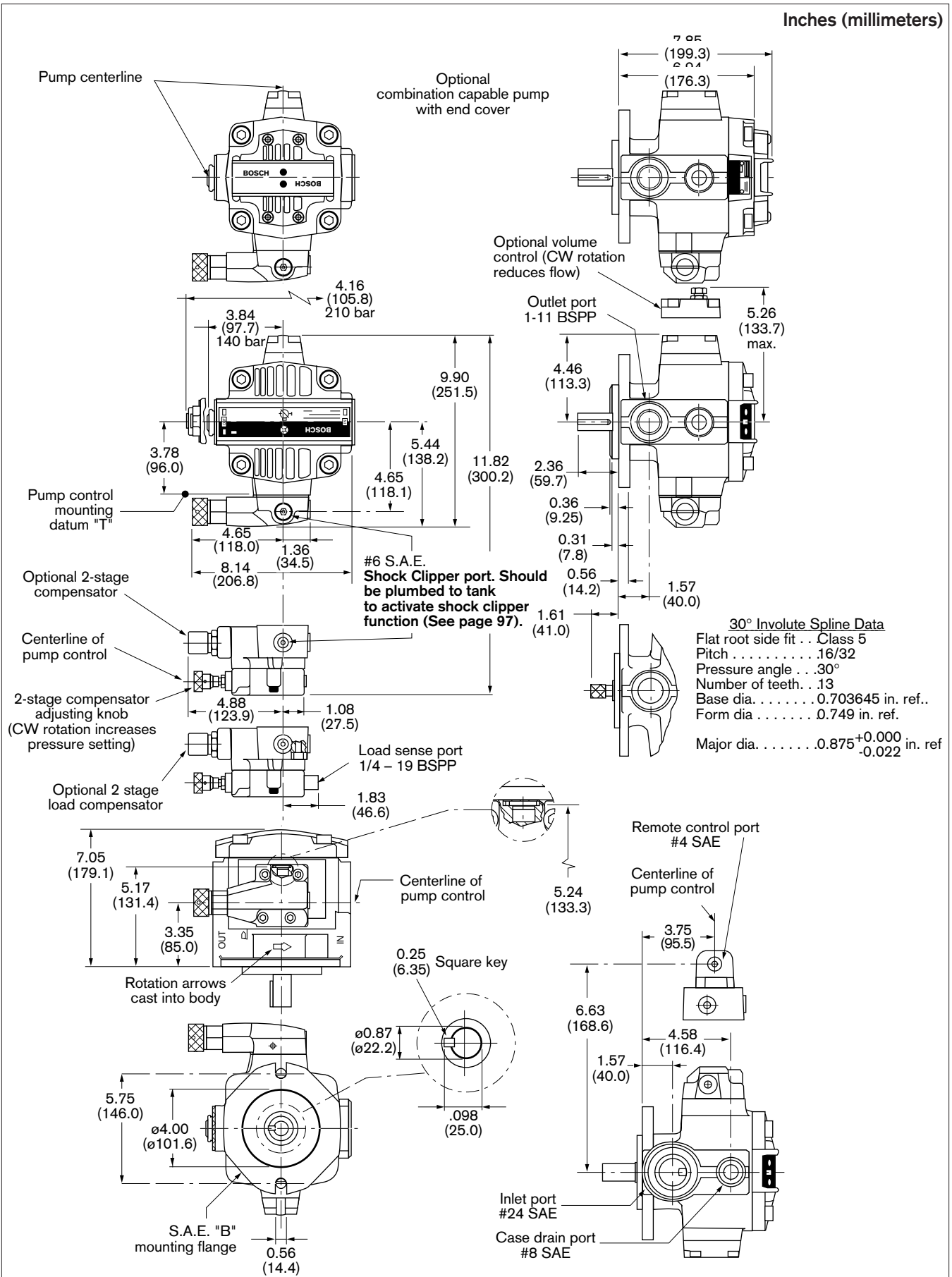

VPV 25/32, Single pump, S.A.E. 'B' flange, w/ solenoid 2-pressure compensator

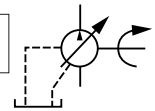

Inches (millimeters)

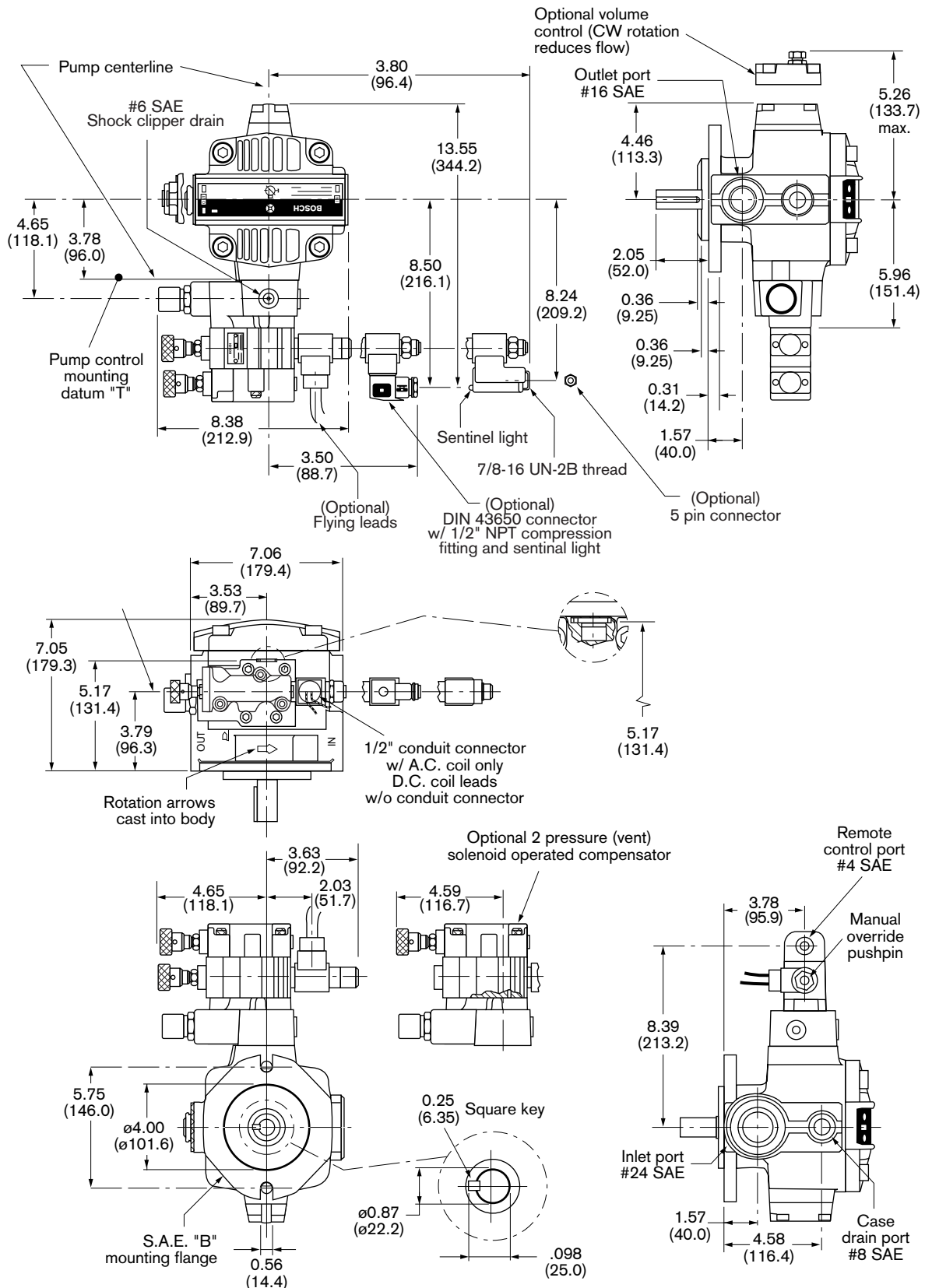

VPV 25/32, Single pump, S.A.E. 'B' flange, w/ NG6 pilot valve

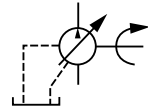

Inches (millimeters)

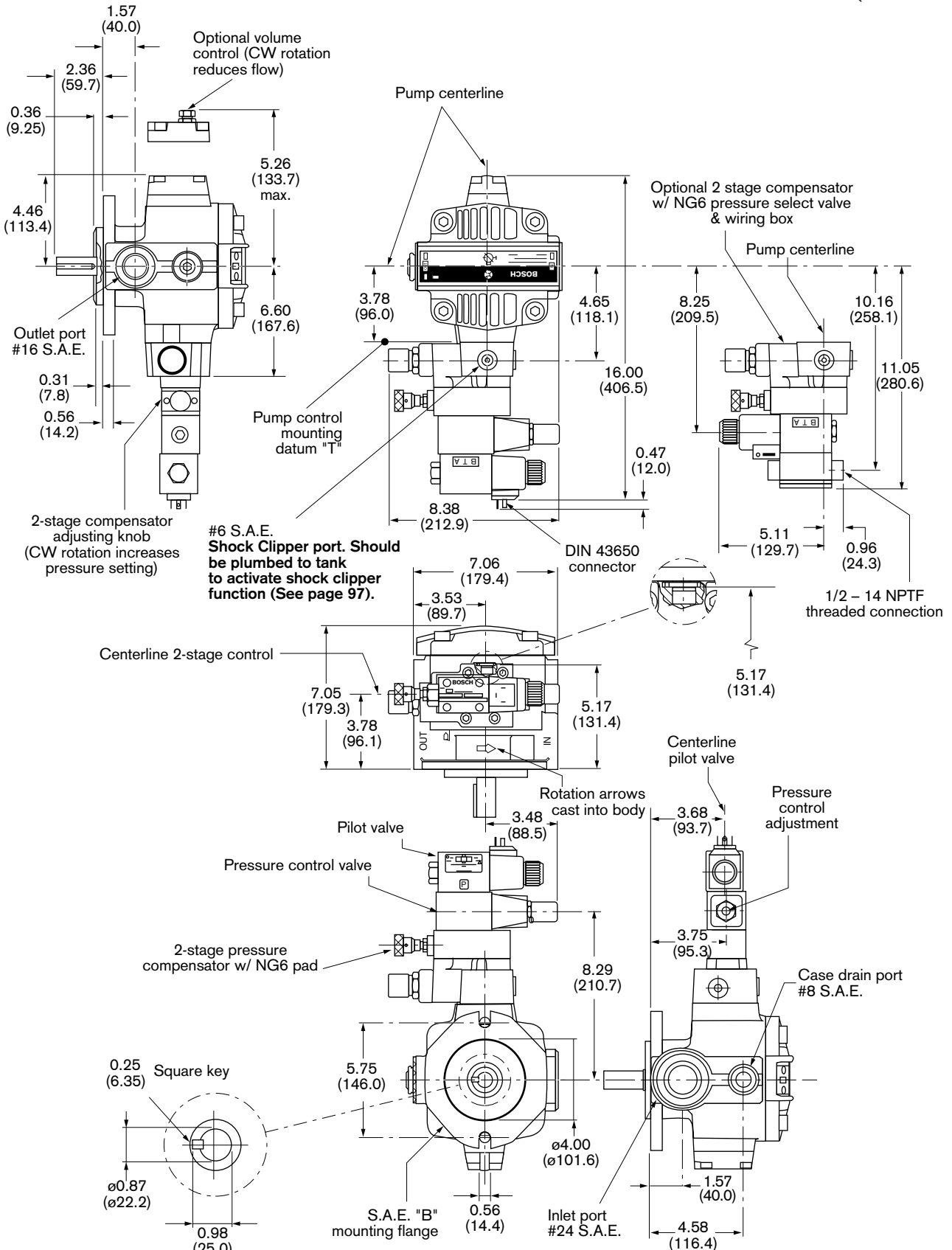

SCALE: 2X

VPV 45/63/80, Single pump, S.A.E. 'C' flange, RH rotation

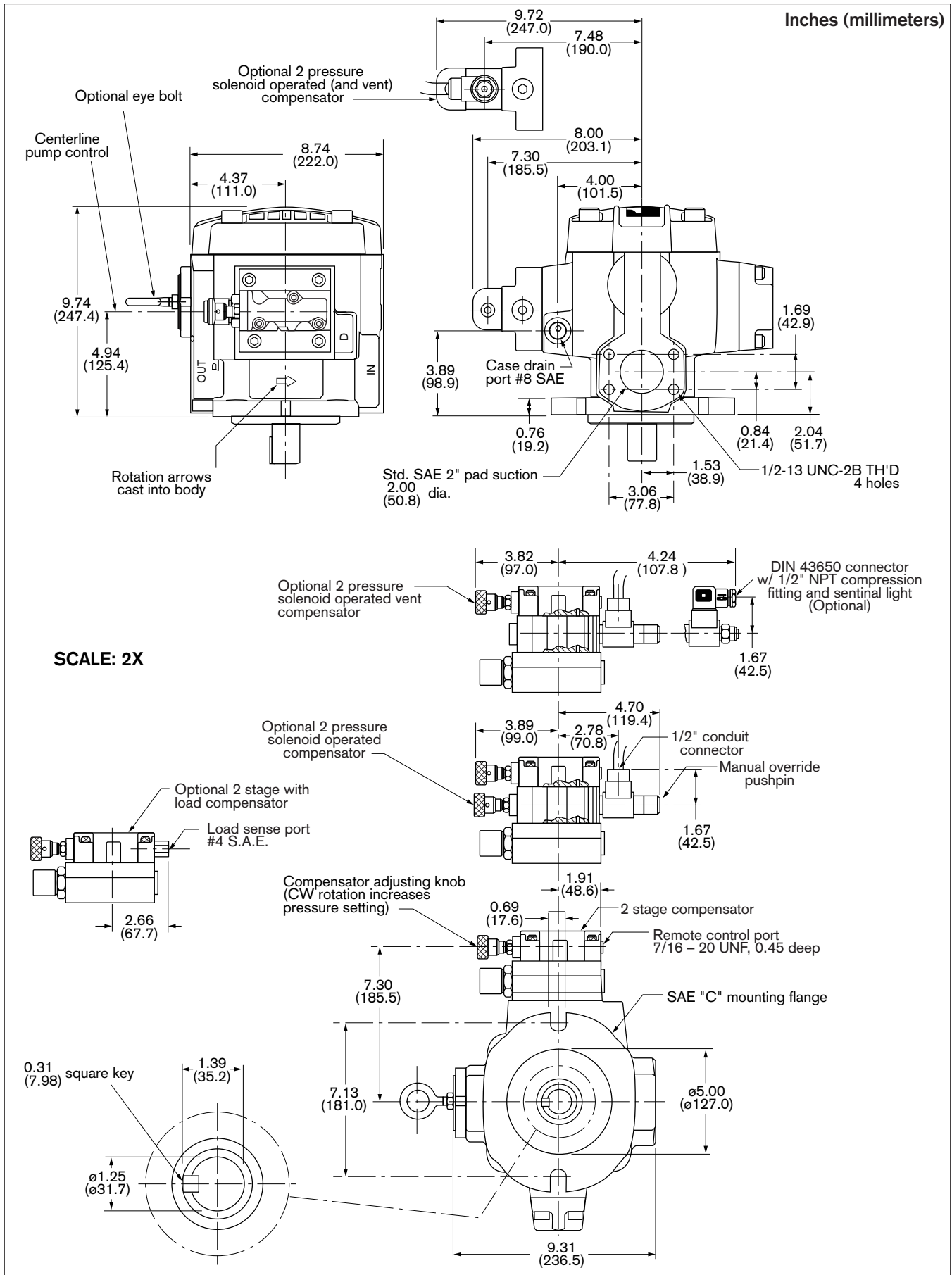
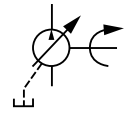

VPV 45/63/80, Single pump, S.A.E. 'C' flange, RH rotation, (continued)

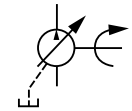

Inches (millimeters)

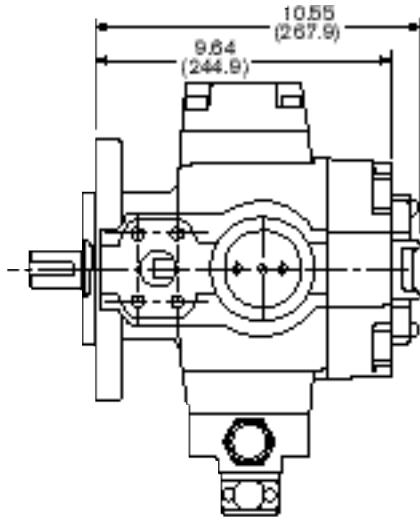

Optional combination capable pump with end cover (P1 Version)

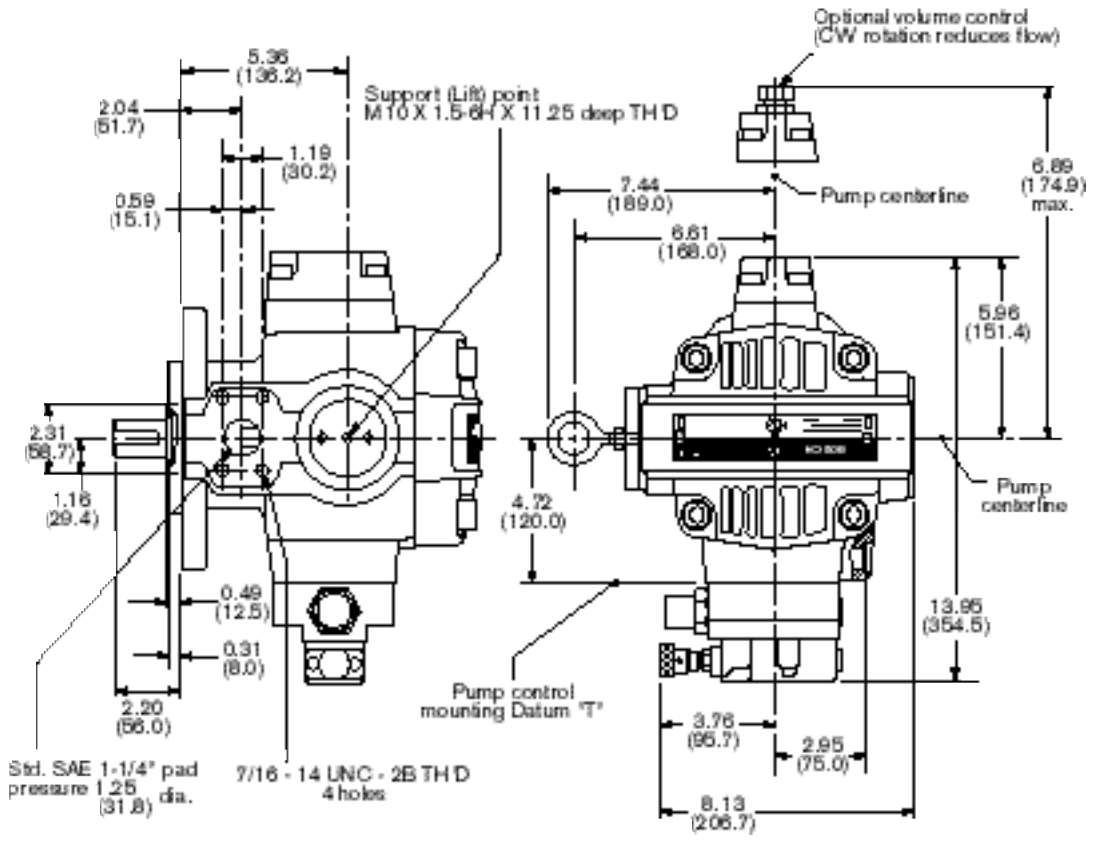
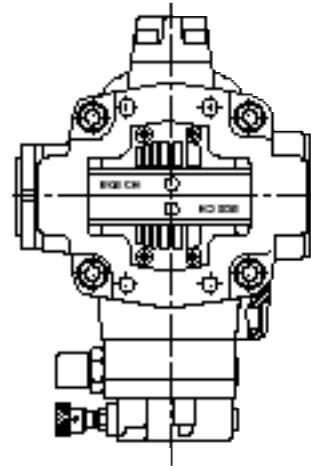

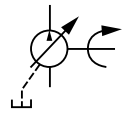

VPV 45/63/80, Single pump, Metric flange, RH Rotation

Inches (millimeters)

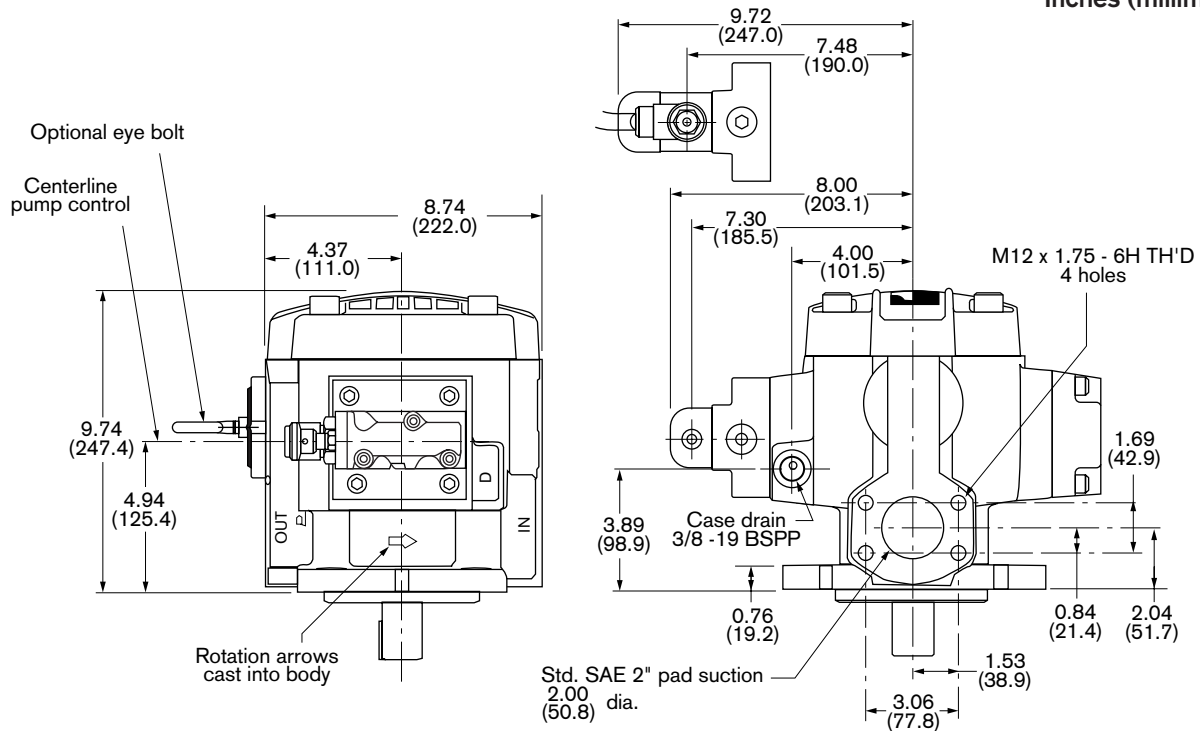

SCALE: 2X

SINGLE STAGE CONTROL
 NOT AVAILABLE ON VPV 45-164

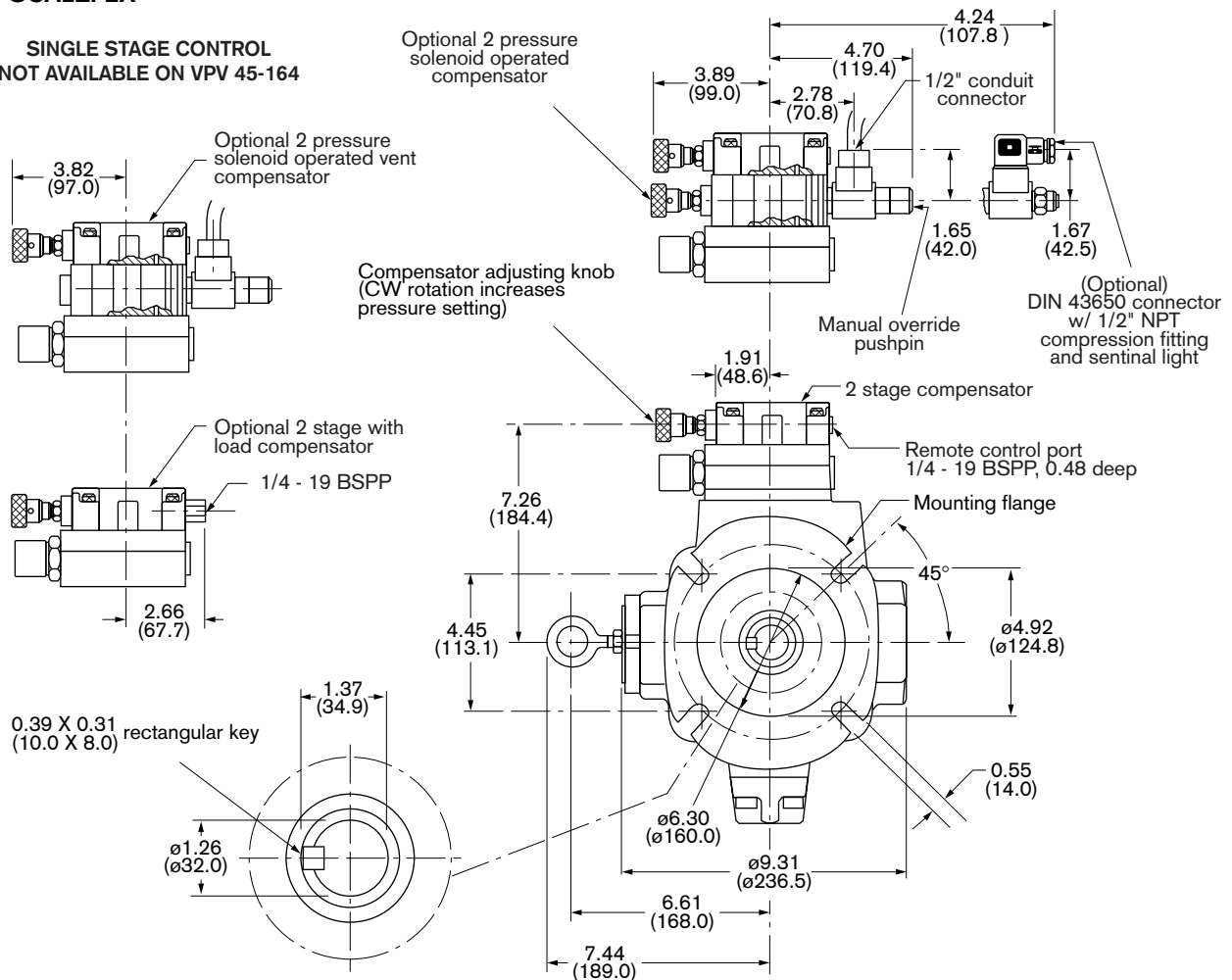

VPV 45/63/80, Single pump, Metric flange, RH Rotation, (continued)

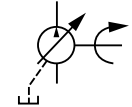

Inches (millimeters)

Optional combination capable pump
with end cover (P1 Version)

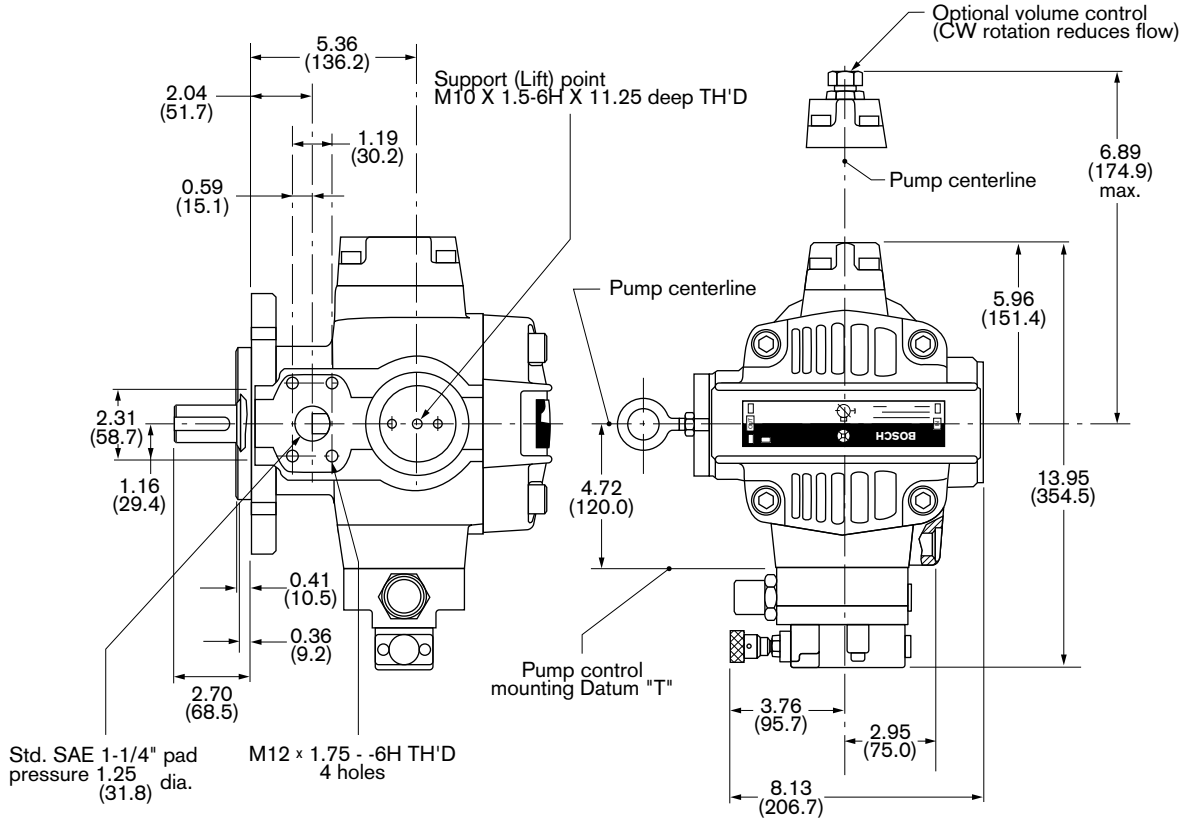
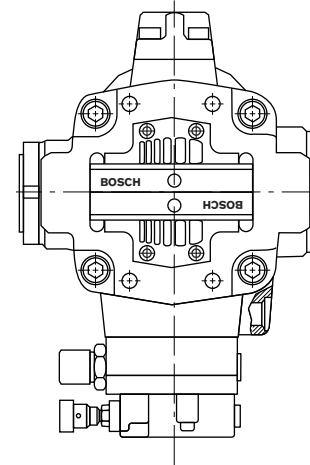
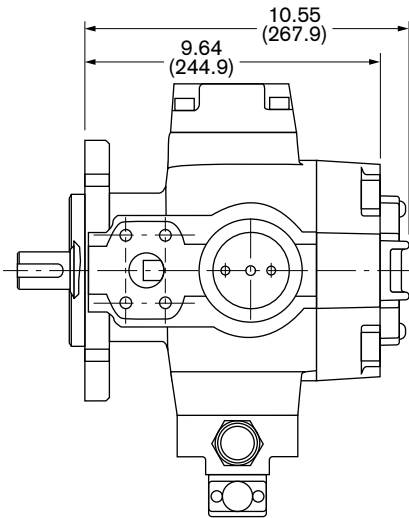

VPV 100/130/164, Single pump, S.A.E. 'D' flange, RH rotation

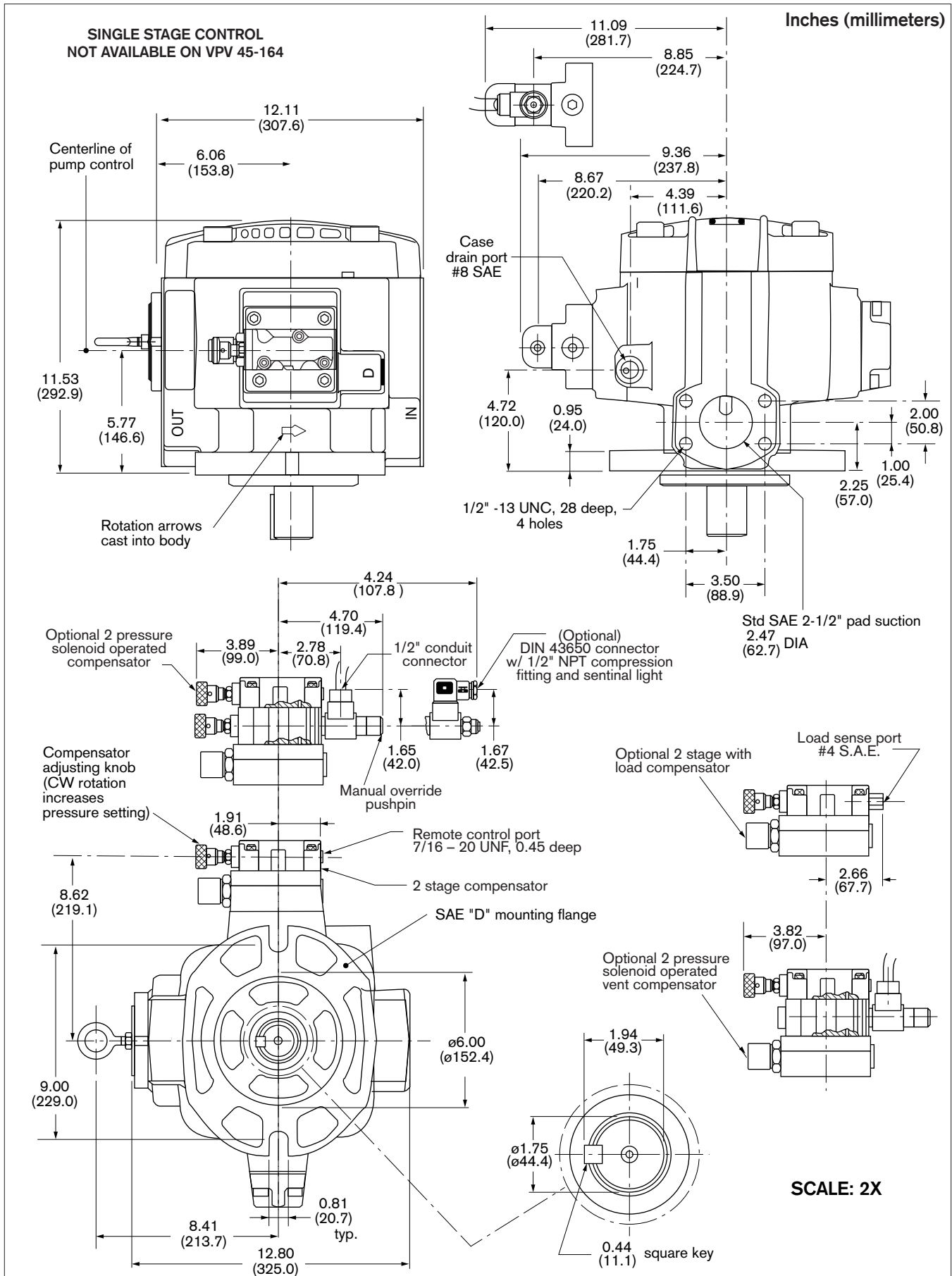
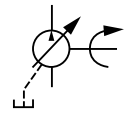

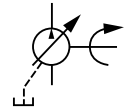

VPV 100/130/164, Single pump, S.A.E. 'D' flange, RH rotation (continued)

Inches (millimeters)

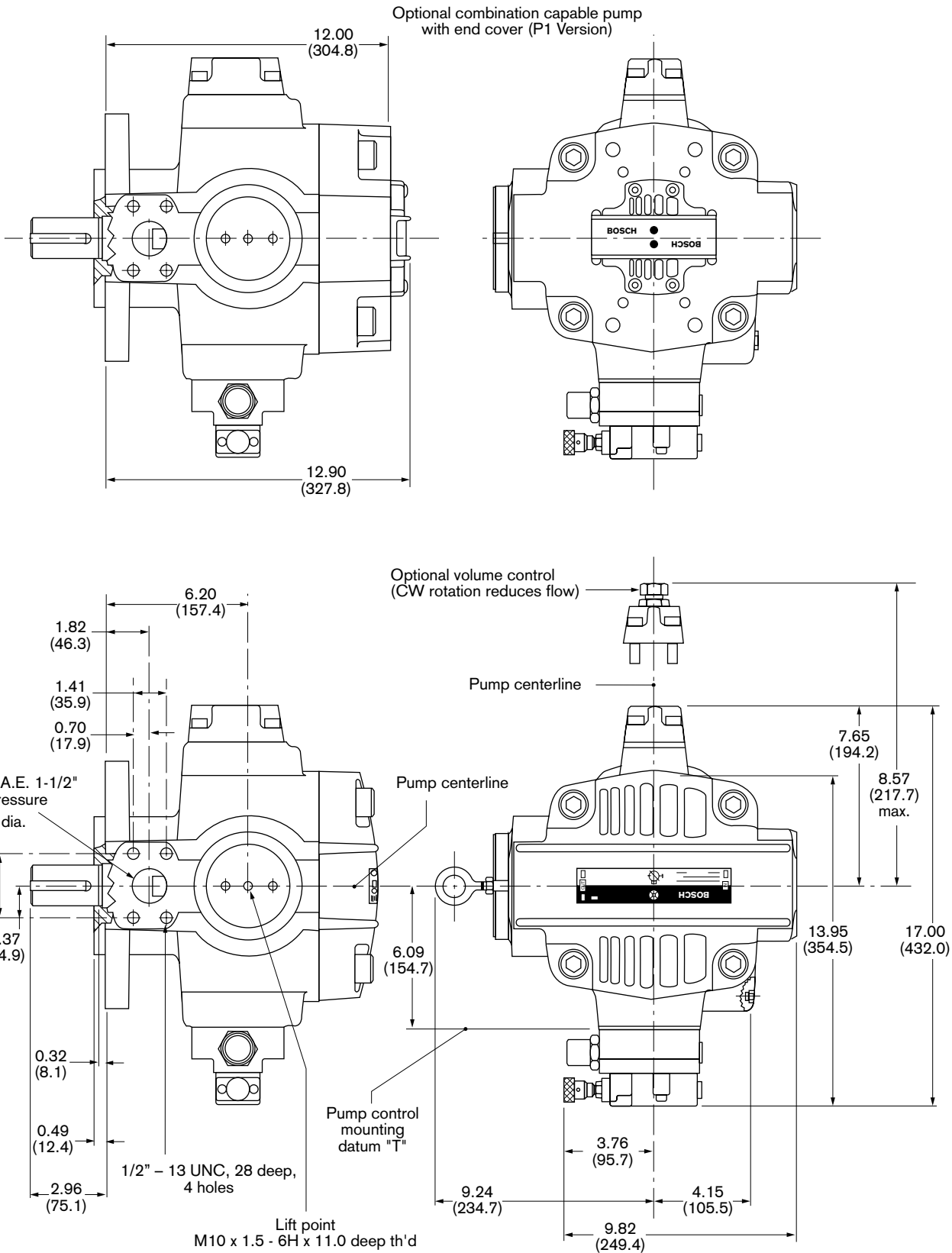

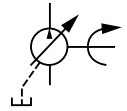

VPV 100/130/164, Single pump, Metric flange, RH rotation

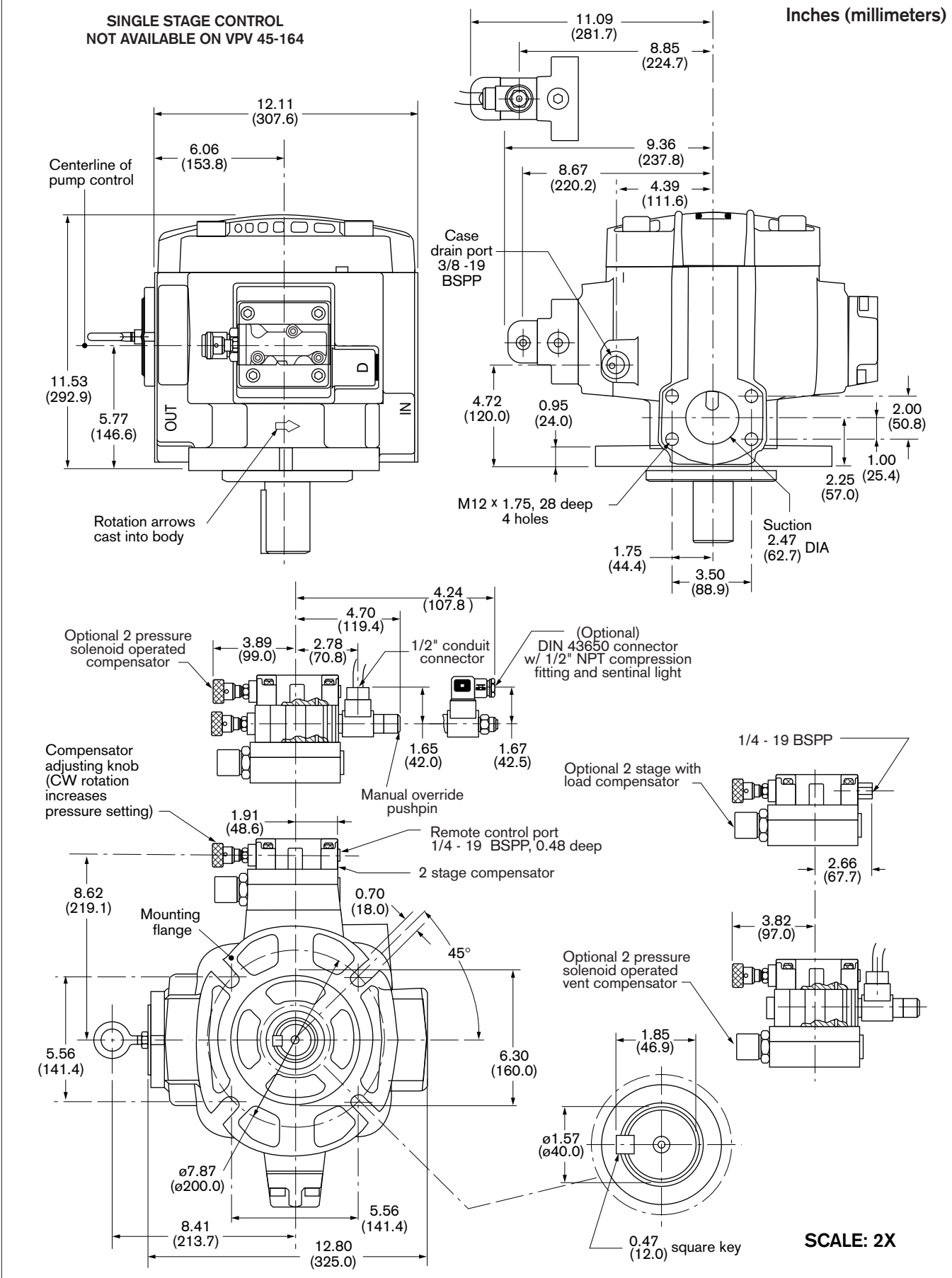

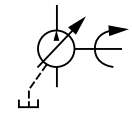

VPV 100/130/164, Single pump, Metric flange, RH rotation (continued)

Inches (millimeters)

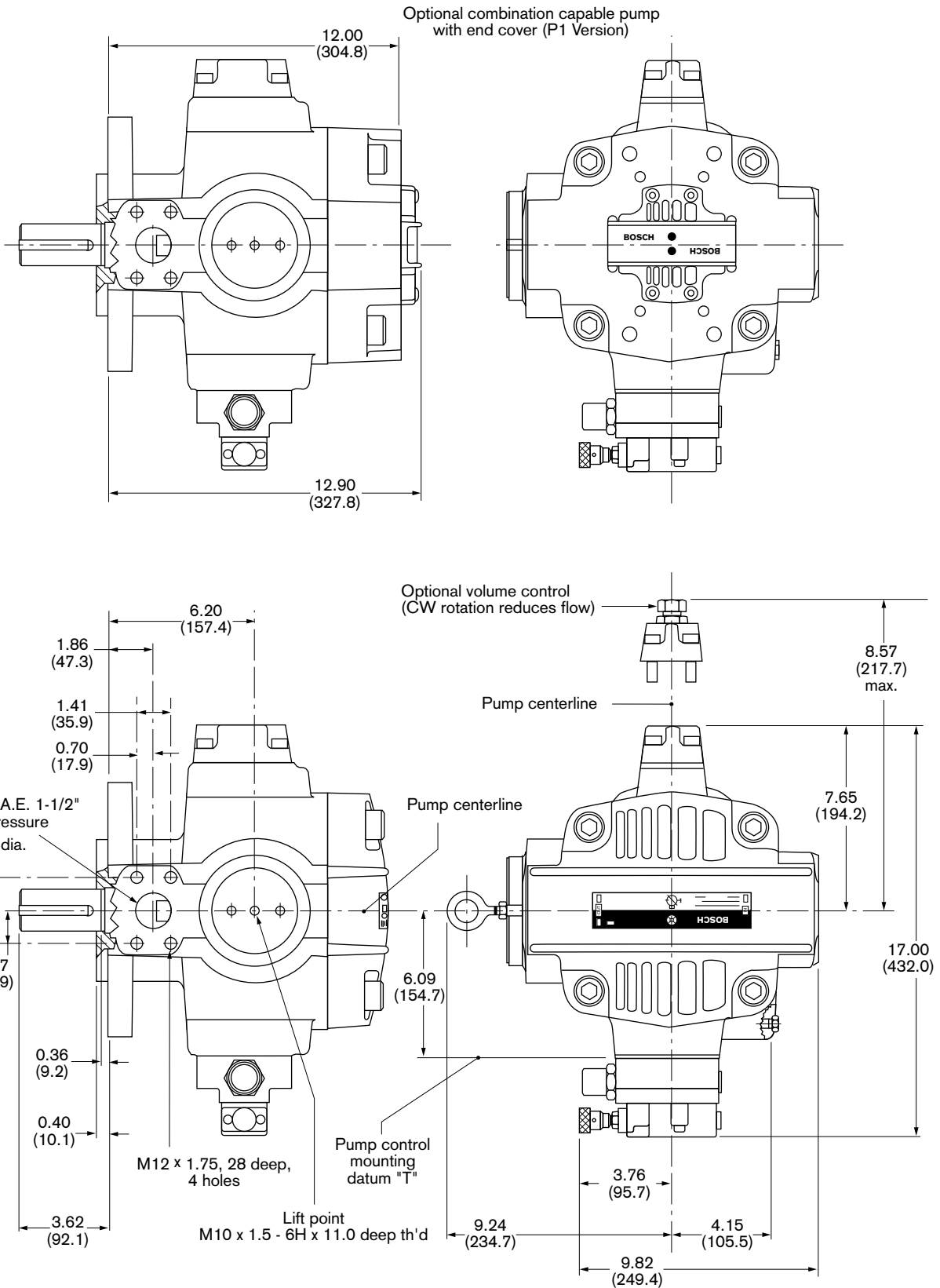

VPV 16, Combination pump, S.A.E. 'A' flange, RH rotation

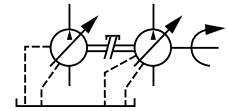

Inches (millimeters)

VIEW A-A

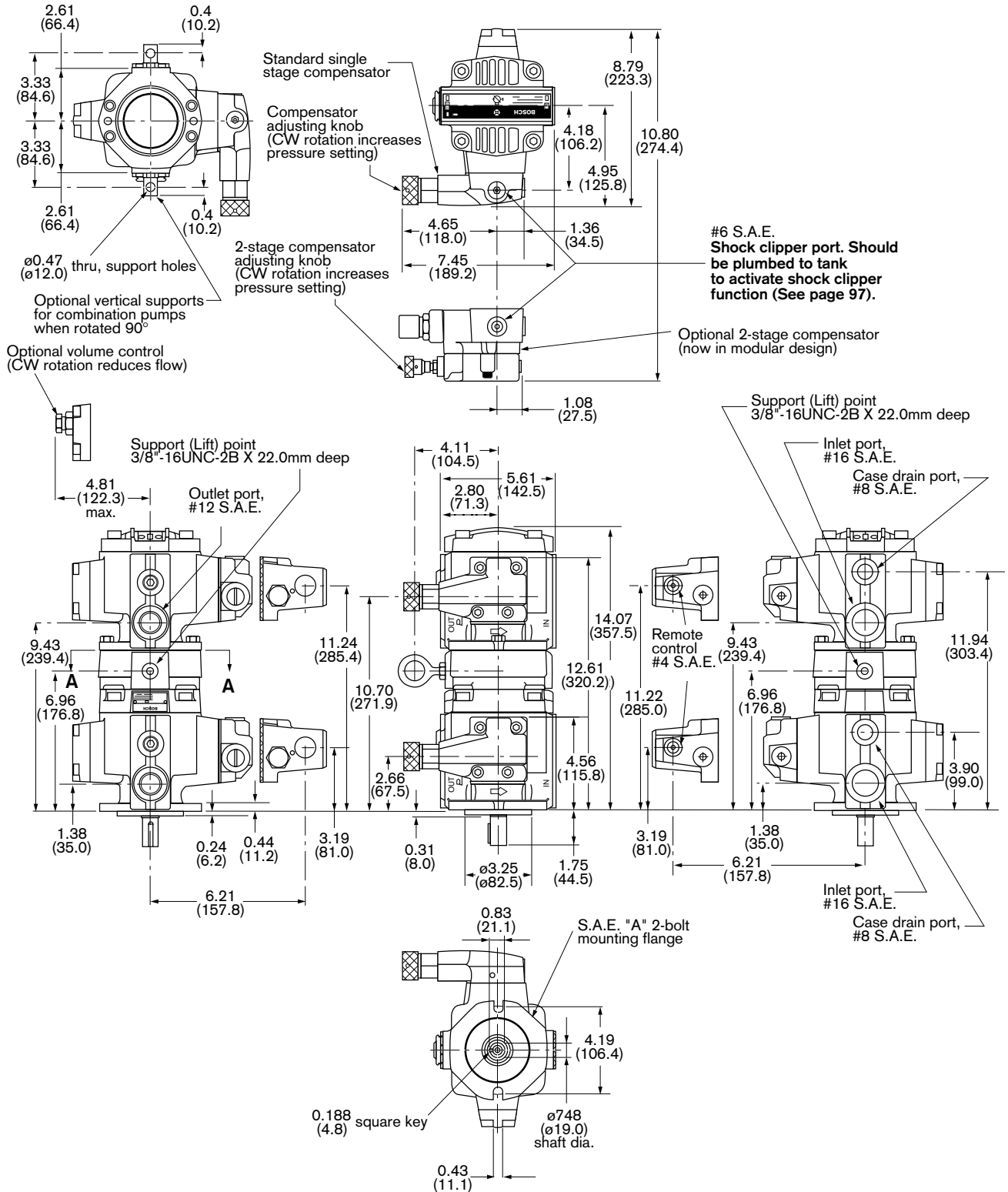

VPV 25/32, Combination pump, S.A.E. 'B' flange, RH rotation

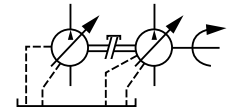

Inches (millimeters)

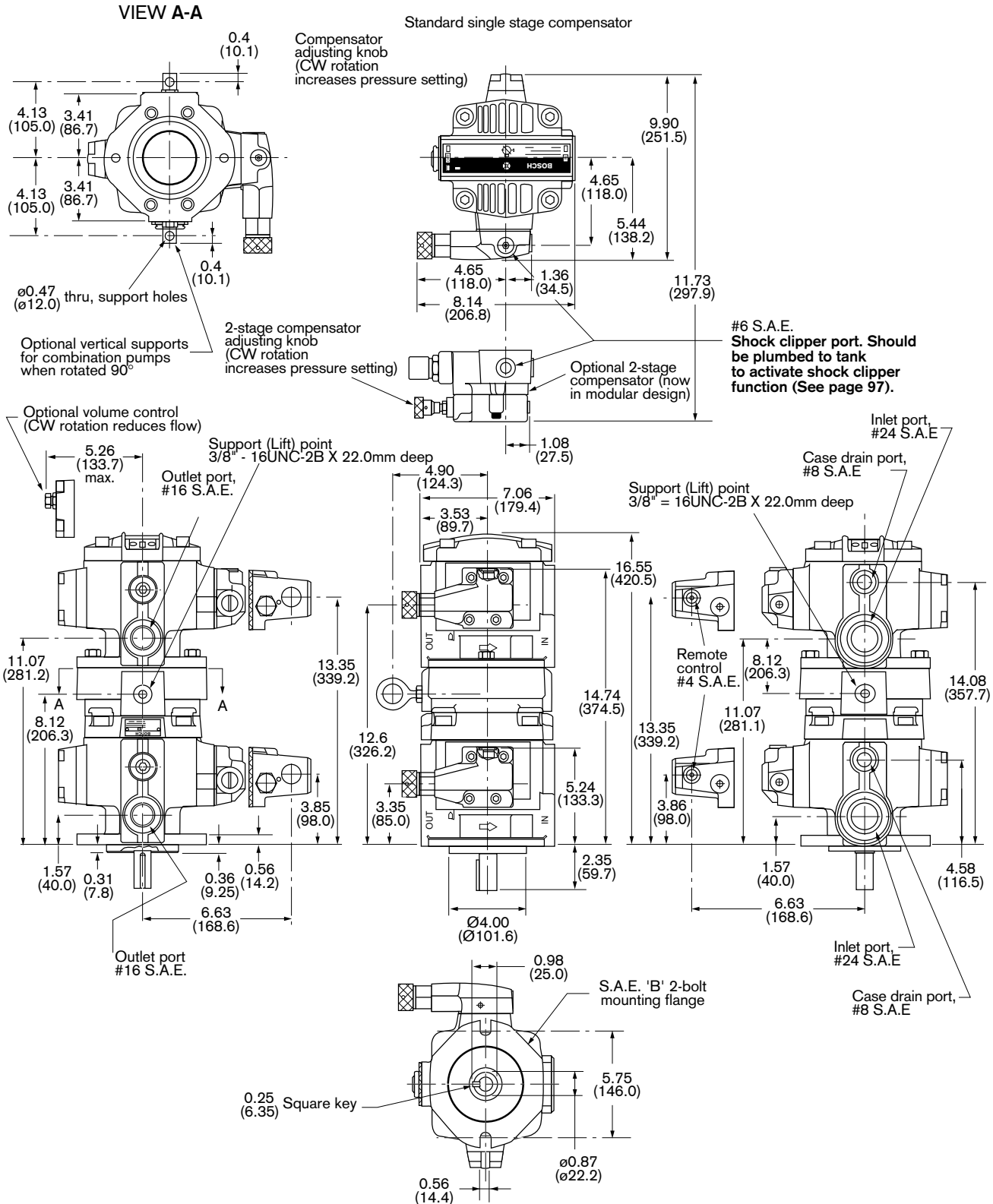

VPV 32/16, Combination pump, S.A.E. 'B' flange, RH rotation

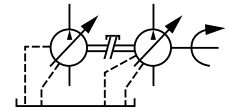

Inches (millimeters)

VIEW B-B

VIEW A-A

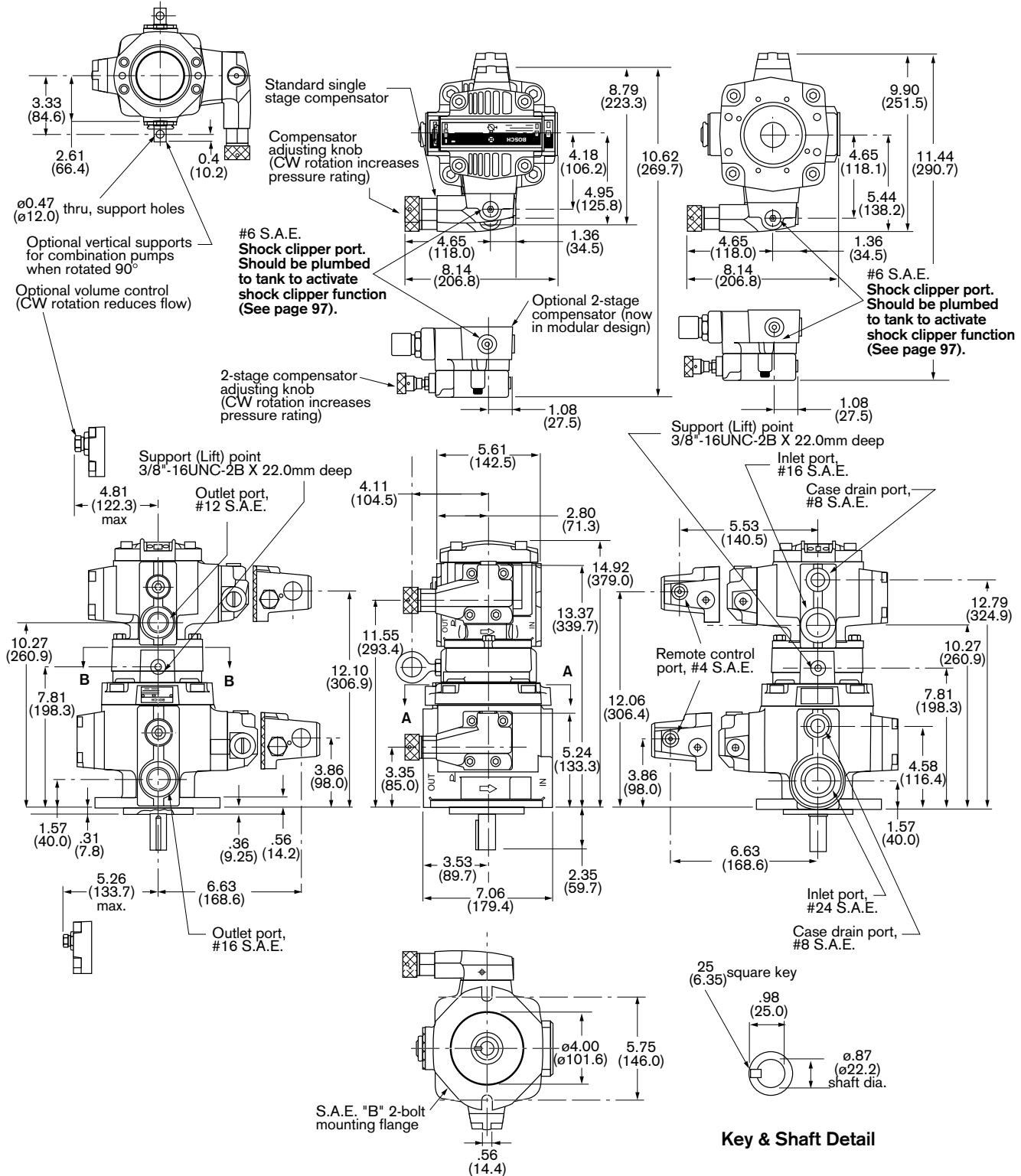

VPV 32/25, Combination pump, S.A.E. to 'F' gear, RH rotation

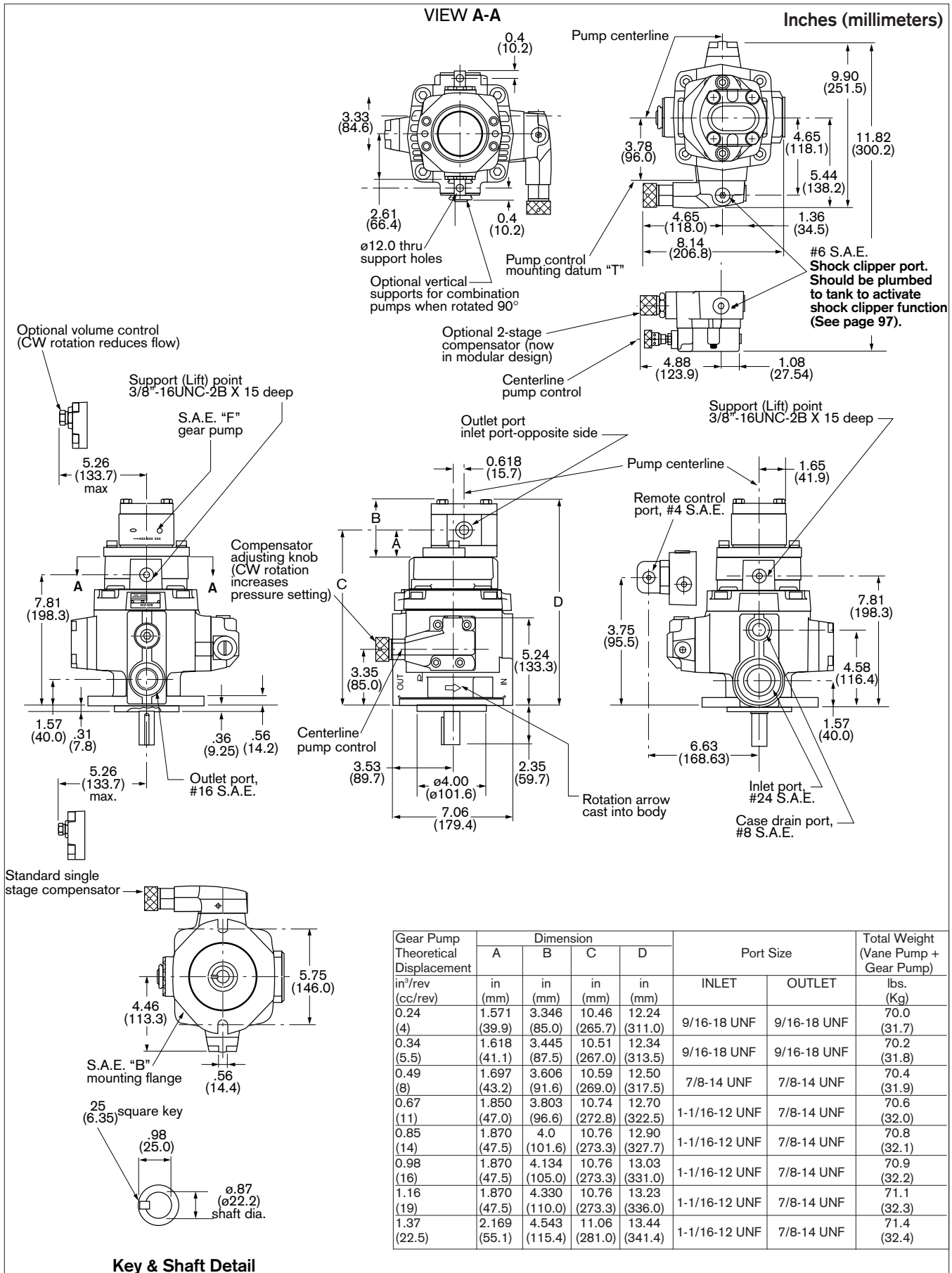
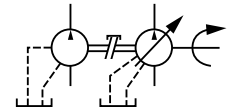

VPV 45/63/80 to VPV 16, S.A.E. & Metric Combination

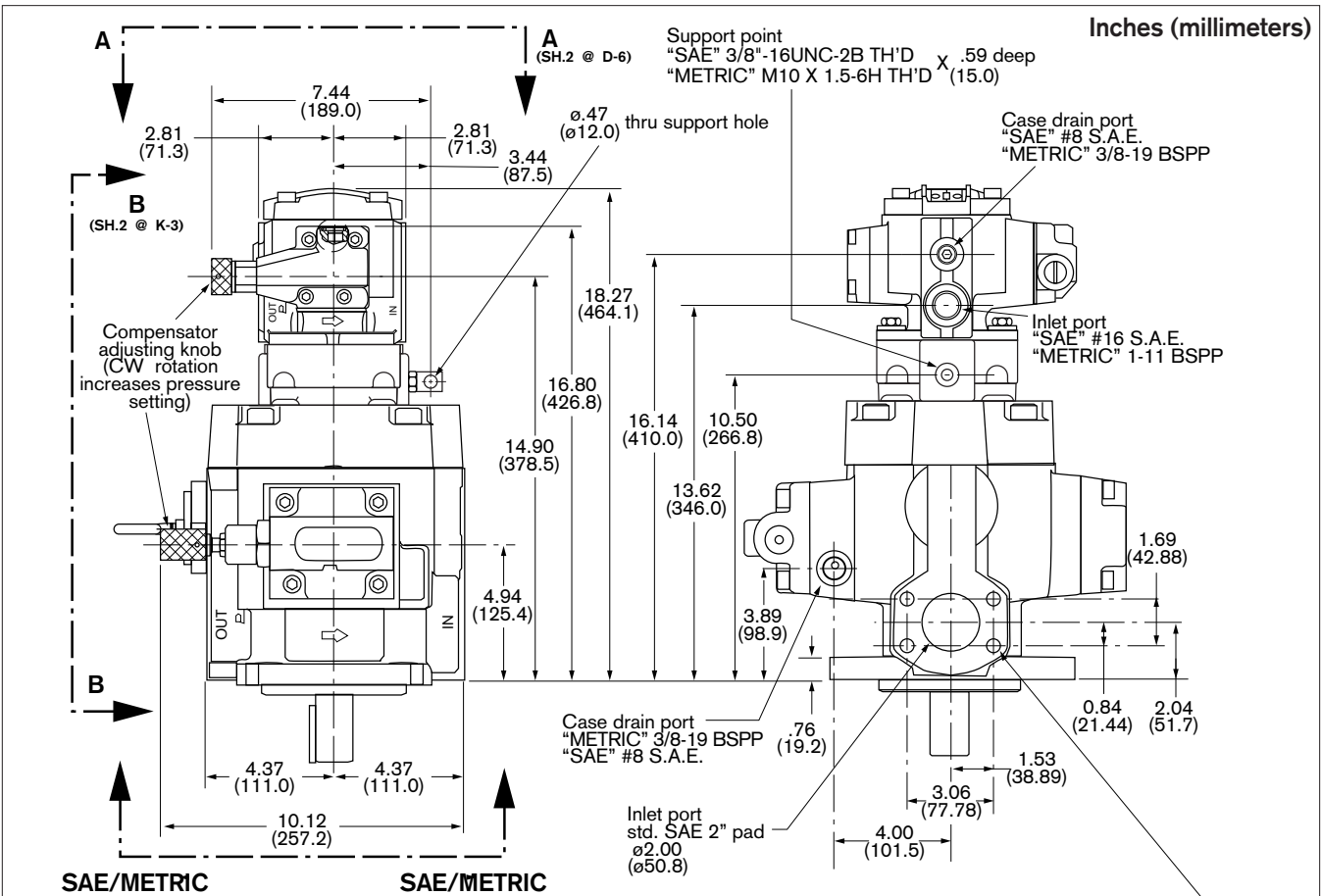
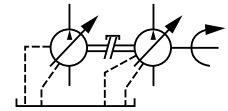

SINGLE STAGE CONTROL
 NOT AVAILABLE ON VPV 45-164

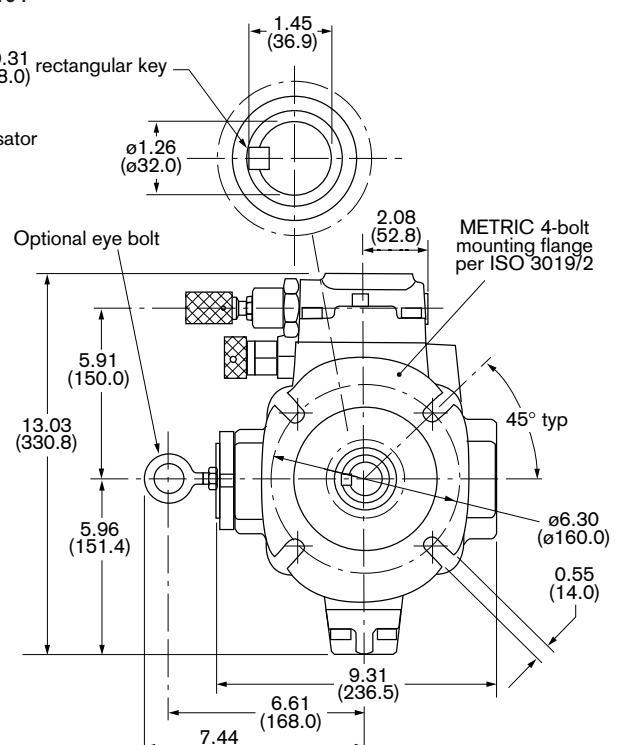
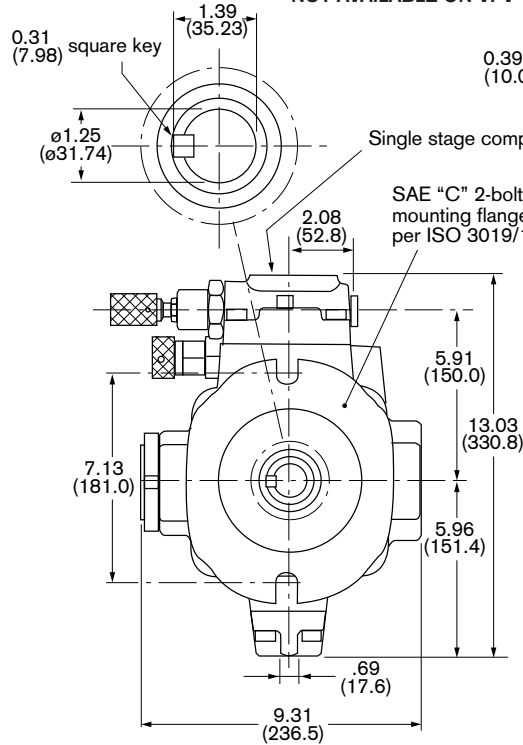

VPV 45/63/80 to VPV 16 (continued)

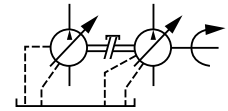

Inches (millimeters)

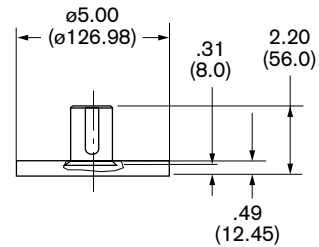
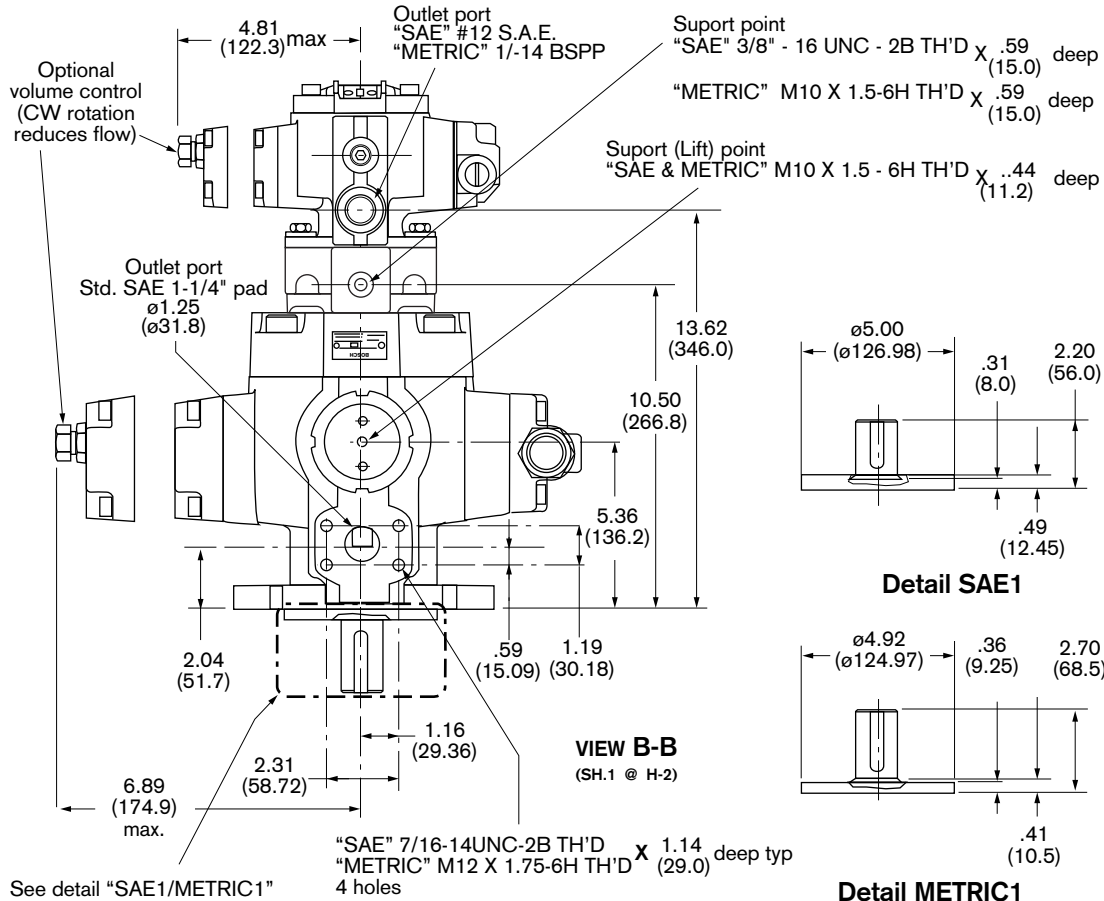

Detail SAE1

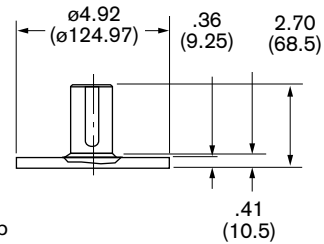

Detail METRIC1

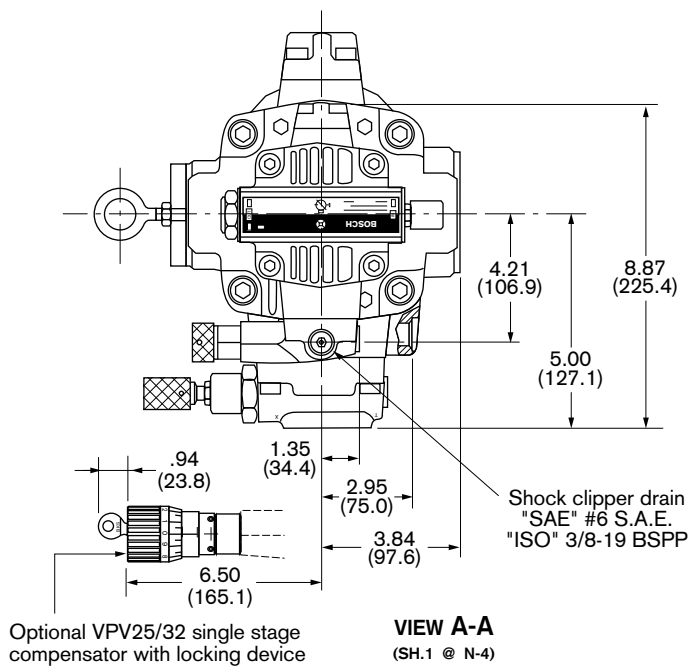

VPV 45/63/80 to VPV 16 (continued)

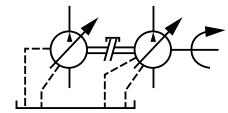

Inches (millimeters)

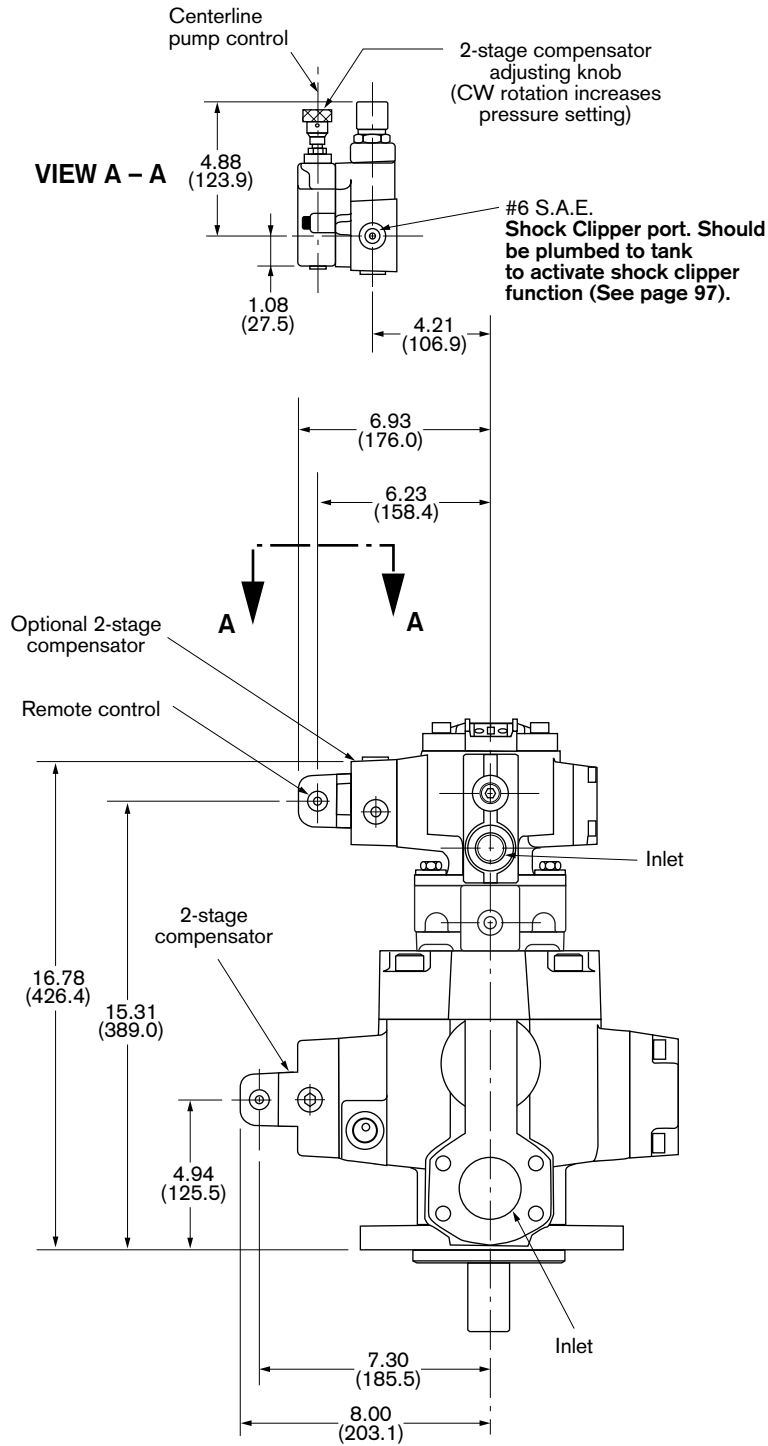

VPV 45/63/80 to VPV 25/32, S.A.E. & Metric Combination

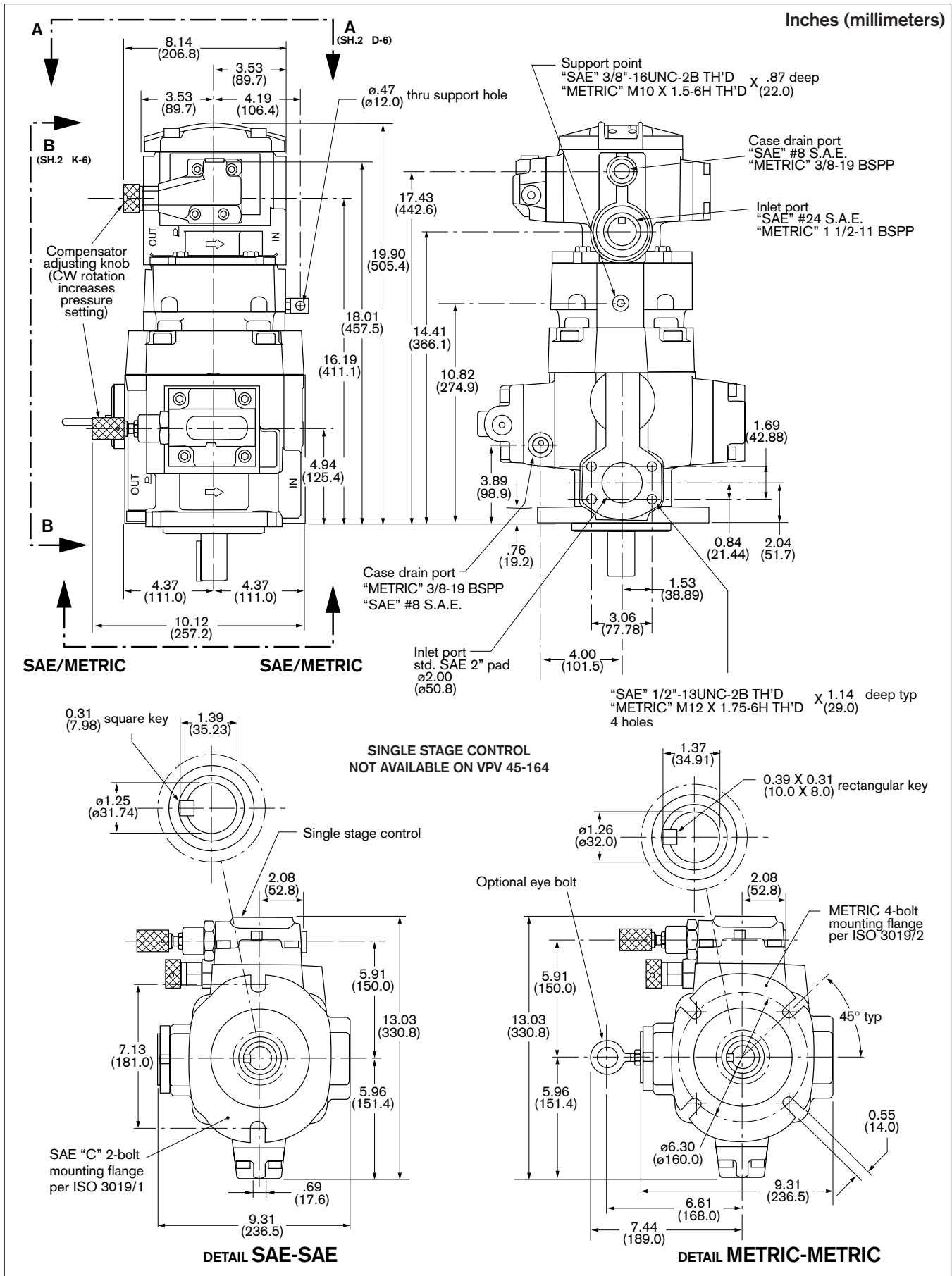
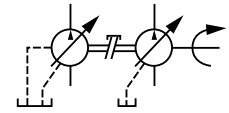

VPV 45/63/80 to VPV 25/32 (continued)

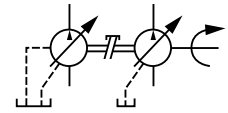

Inches (millimeters)

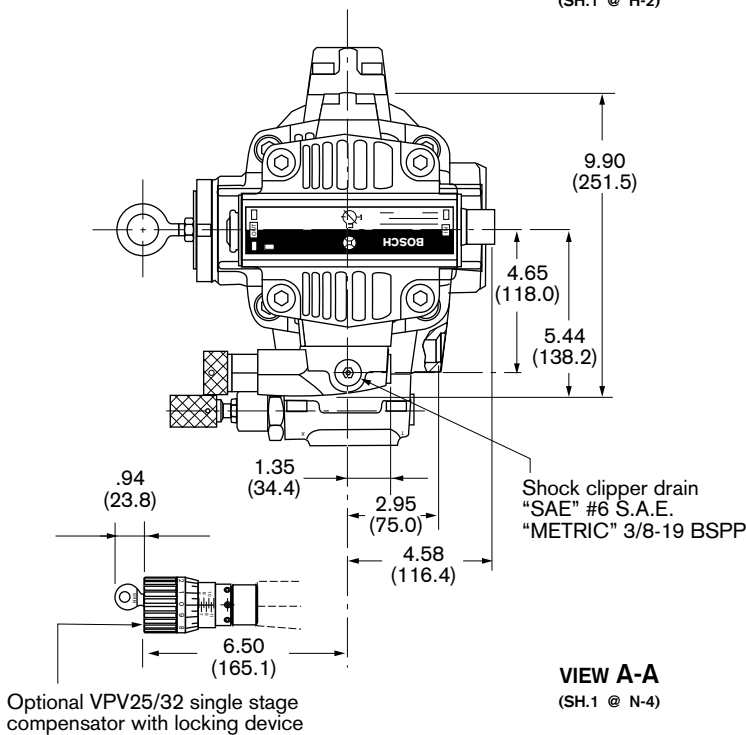
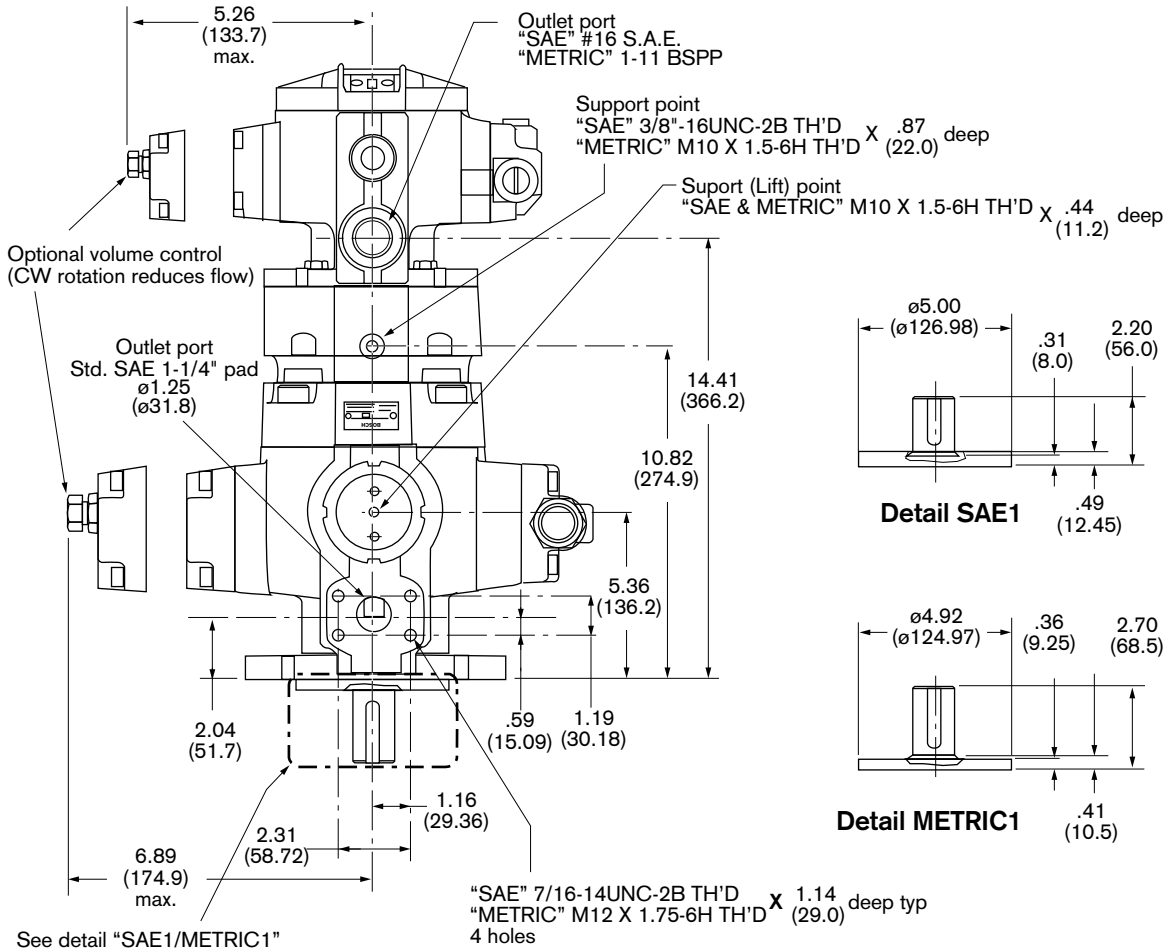

VPV 45/63/80 to VPV 25/32 (continued)

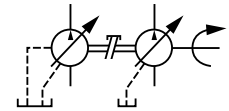

Inches (millimeters)

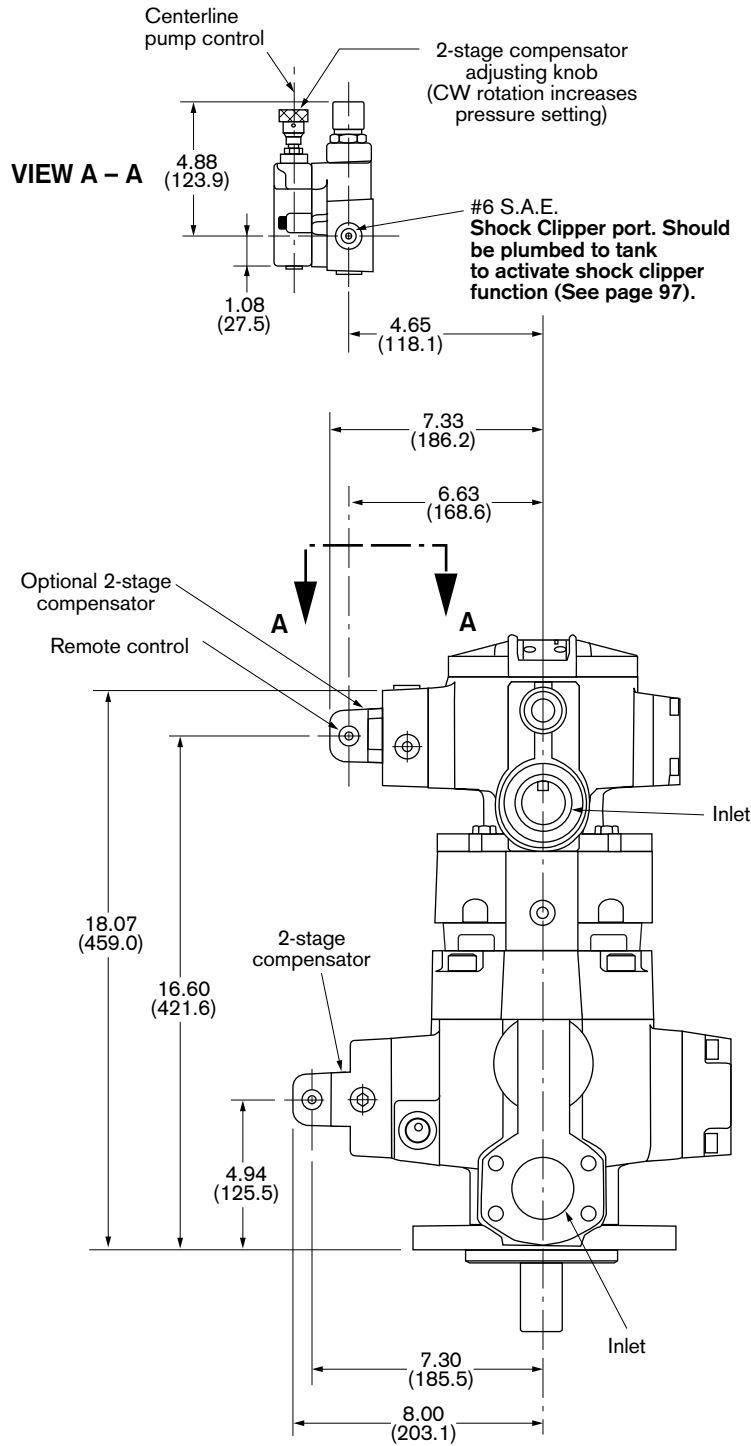

VPV 45/63/80 to an 'F' Gear pump, S.A.E. & Metric Combination

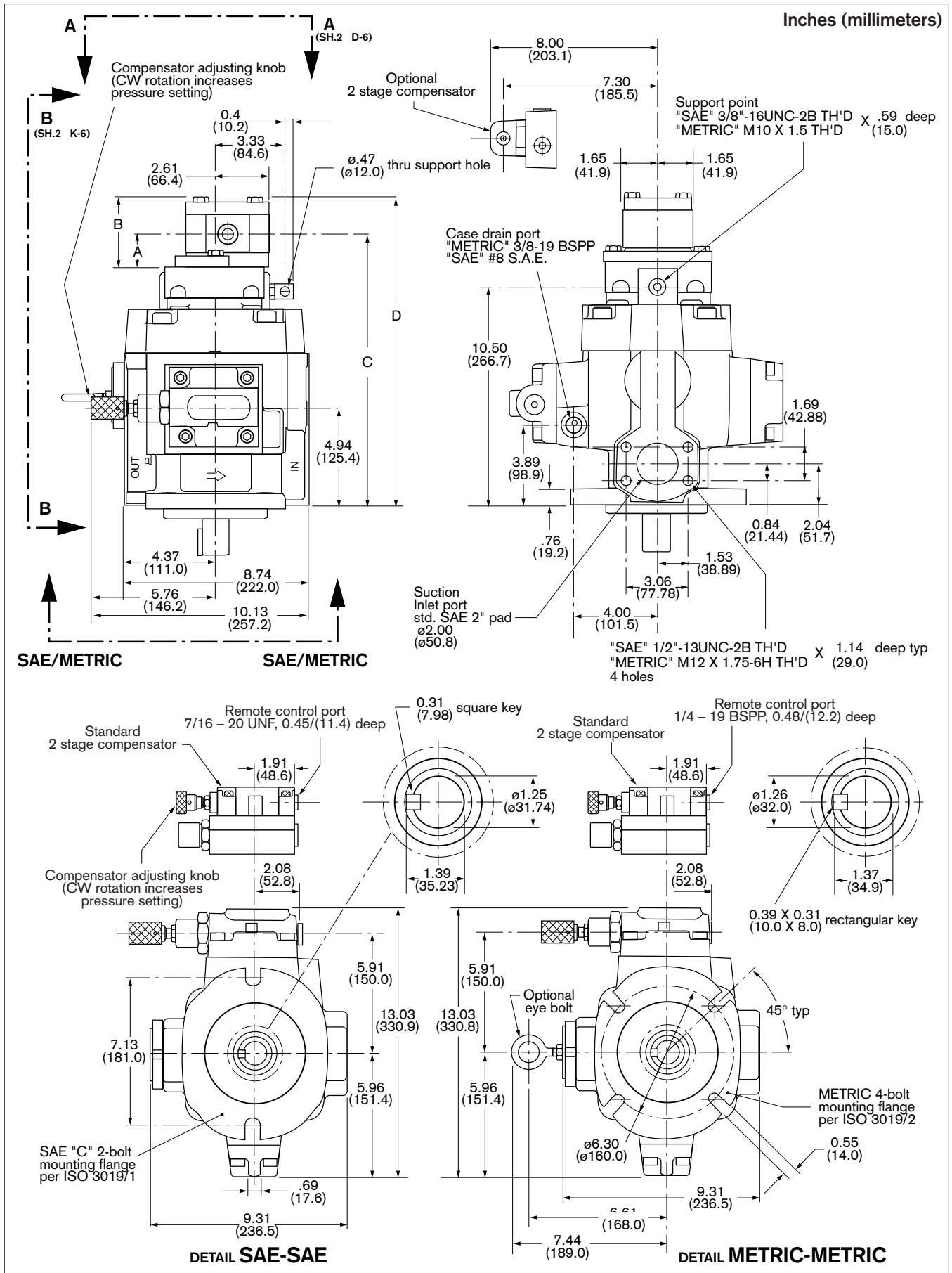
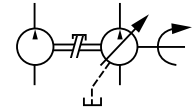

VPV 45/63/80 to an 'F' Gear pump (continued)

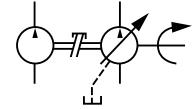

Inches (millimeters)

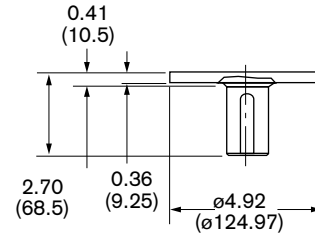
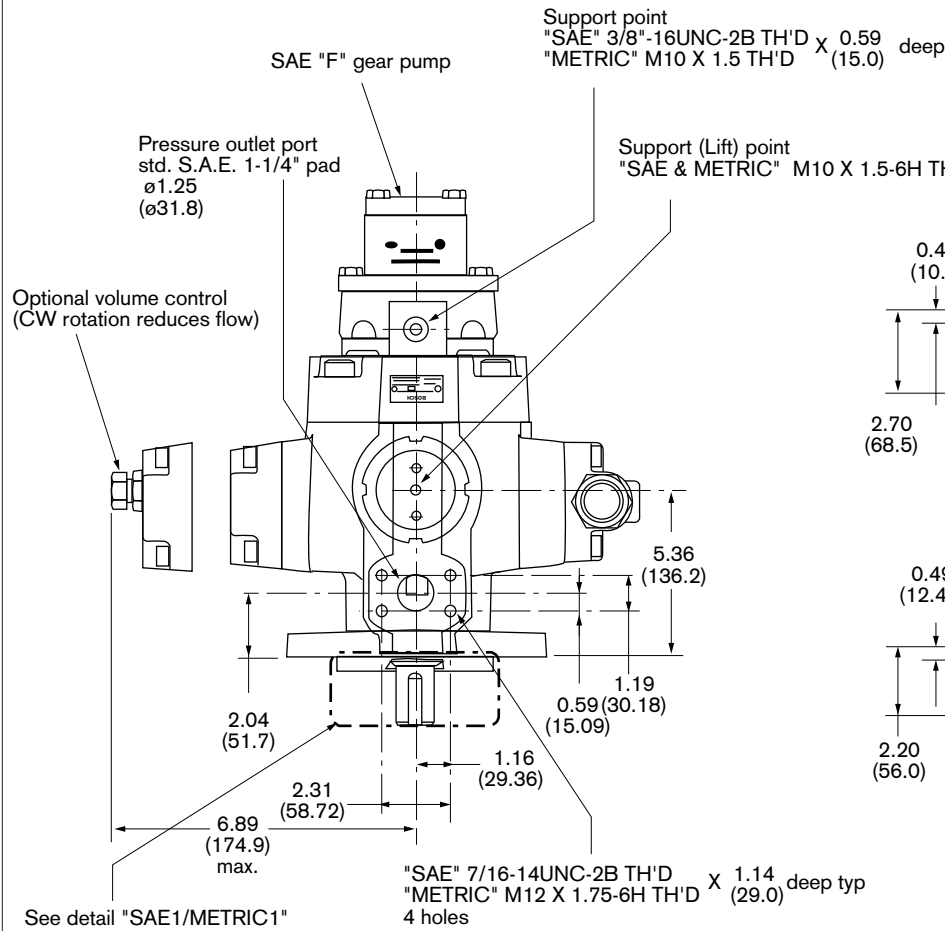

DETAIL METRIC1

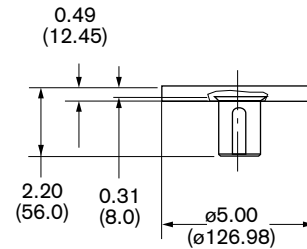

DETAIL SAE1

VIEW B-B
 (SH.1 @ H-2)

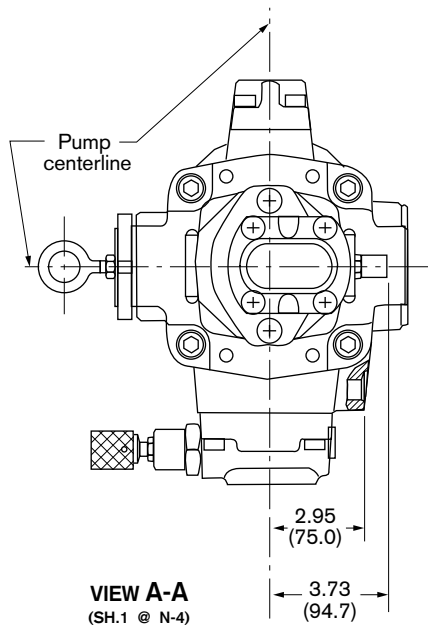

VIEW A-A
 (SH.1 @ N-4)

Gear pump Theoretical Displacement	Dimension						Gear Pump Port Sizes		Total Weight (Vane Pump & Gear Pump)
	A	B	C	D	E	F	Inlet	Outlet	
0.24 (4)	1.571 (39.9)	3.346 (85.0)	13.30 (337.8)	15.08 (383.2)	13.56 (344.6)	15.35 (390.0)	9/16-18 UNF	9/16-18 UNF	135 (61.2)
0.34 (5.5)	1.618 (41.1)	3.445 (87.5)	13.35 (339.1)	15.19 (385.7)	13.62 (345.9)	15.45 (392.5)	9/16-18 UNF	9/16-18 UNF	135.2 (61.3)
0.49 (8)	1.697 (43.2)	3.606 (91.6)	13.43 (341.1)	15.34 (389.7)	13.70 (347.9)	15.61 (396.5)	7/8-14 UNF	7/8-14 UNF	135.4 (61.4)
0.67 (11)	1.850 (47.0)	3.803 (96.6)	13.58 (344.9)	15.49 (393.4)	13.85 (351.7)	15.76 (400.2)	1-1/16-12 UN	7/8-14 UNF	135.6 (61.5)
0.85 (14)	1.870 (47.5)	4.0 (101.6)	13.60 (345.4)	15.69 (398.5)	13.87 (352.2)	15.96 (405.3)	1-1/16-12 UN	7/8-14 UNF	135.8 (61.6)
0.98 (16)	1.870 (47.6)	4.134 (105.0)	13.6 (345.6)	15.86 (403.0)	13.87 (352.4)	16.13 (409.8)	1-1/16-12 UN	7/8-14 UNF	135.9 (61.6)
1.16 (19)	1.870 (47.5)	4.330 (110.0)	13.6 (345.5)	16.06 (408.0)	13.86 (352.3)	16.33 (414.8)	1-1/16-12 UN	7/8-14 UNF	136.1 (61.7)
1.37 (22.5)	2.169 (55.1)	4.543 (115.4)	13.90 (353.12)	16.27 (413.4)	14.17 (359.9)	16.54 (420.2)	1-1/16-12 UN	7/8-14 UNF	136.4 (61.9)

VPV 45/63/80 to an 'F' Gear pump (continued)

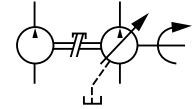

Inches (millimeters)

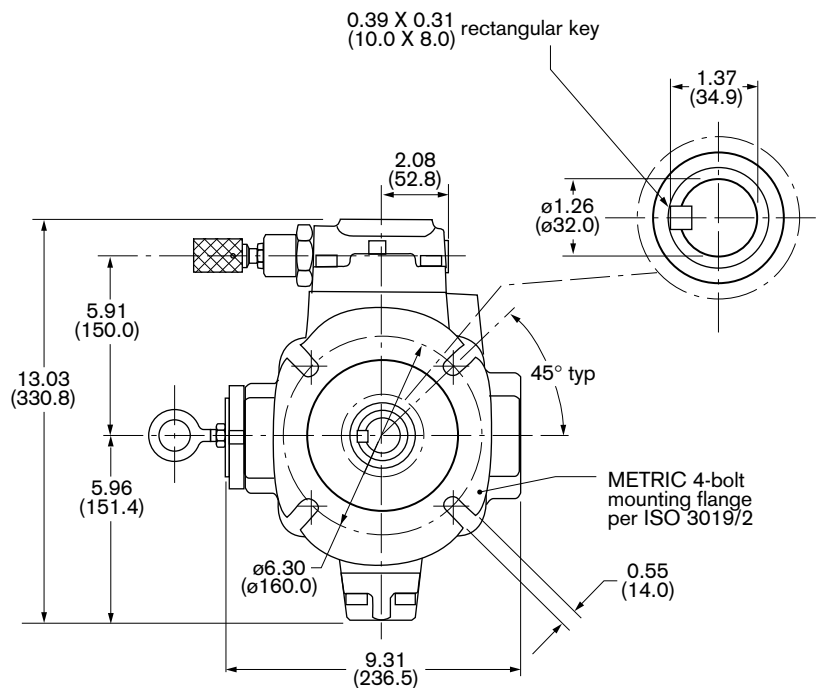
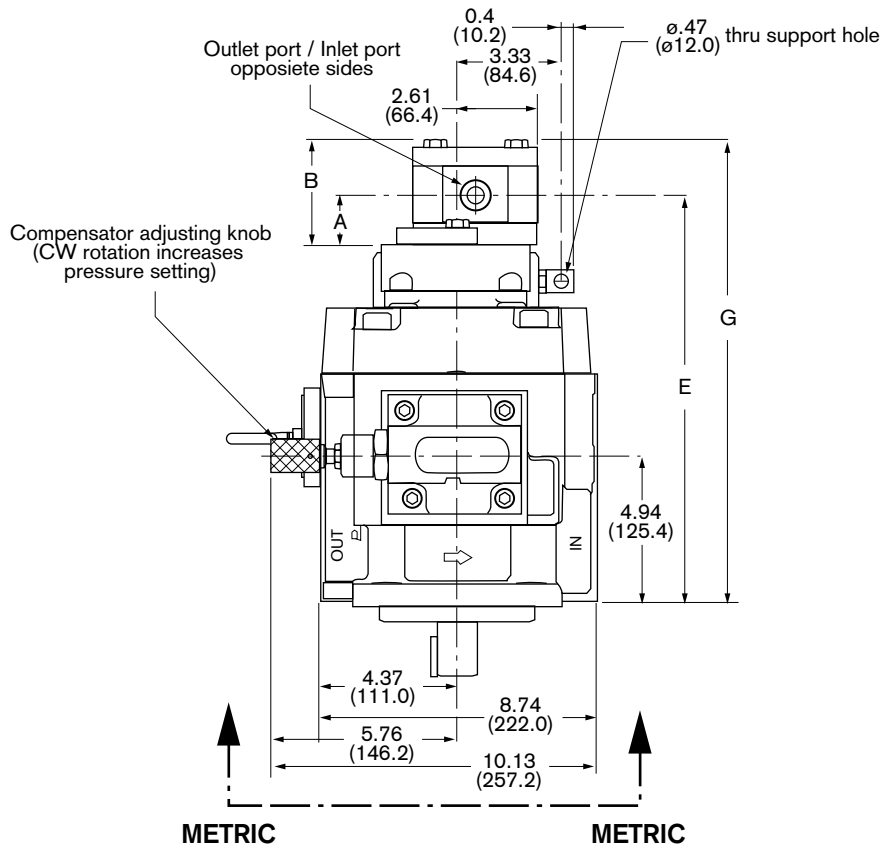

VPV 45/63/80 to an 'G' Gear pump, S.A.E. & Metric Combination

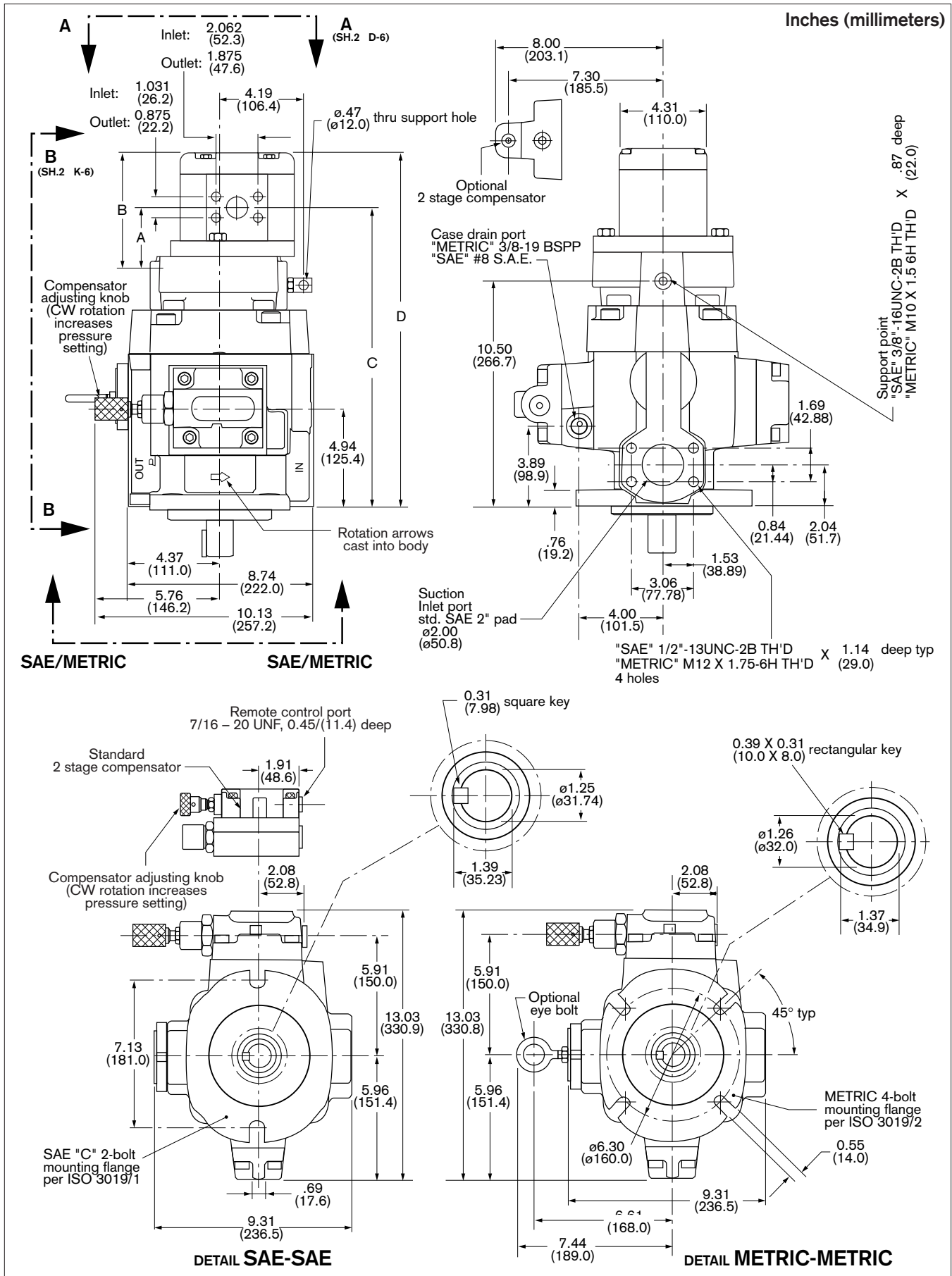
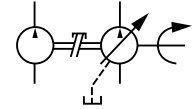

VPV 45/63/80 to an 'G' Gear pump (continued)

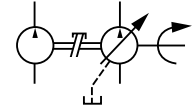

Inches (millimeters)

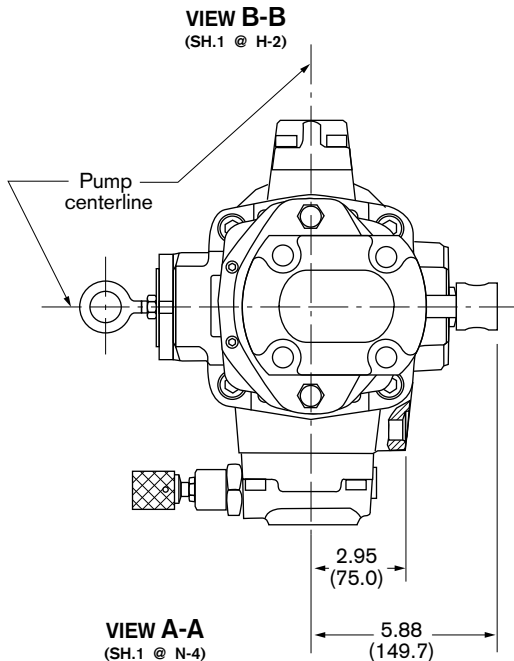
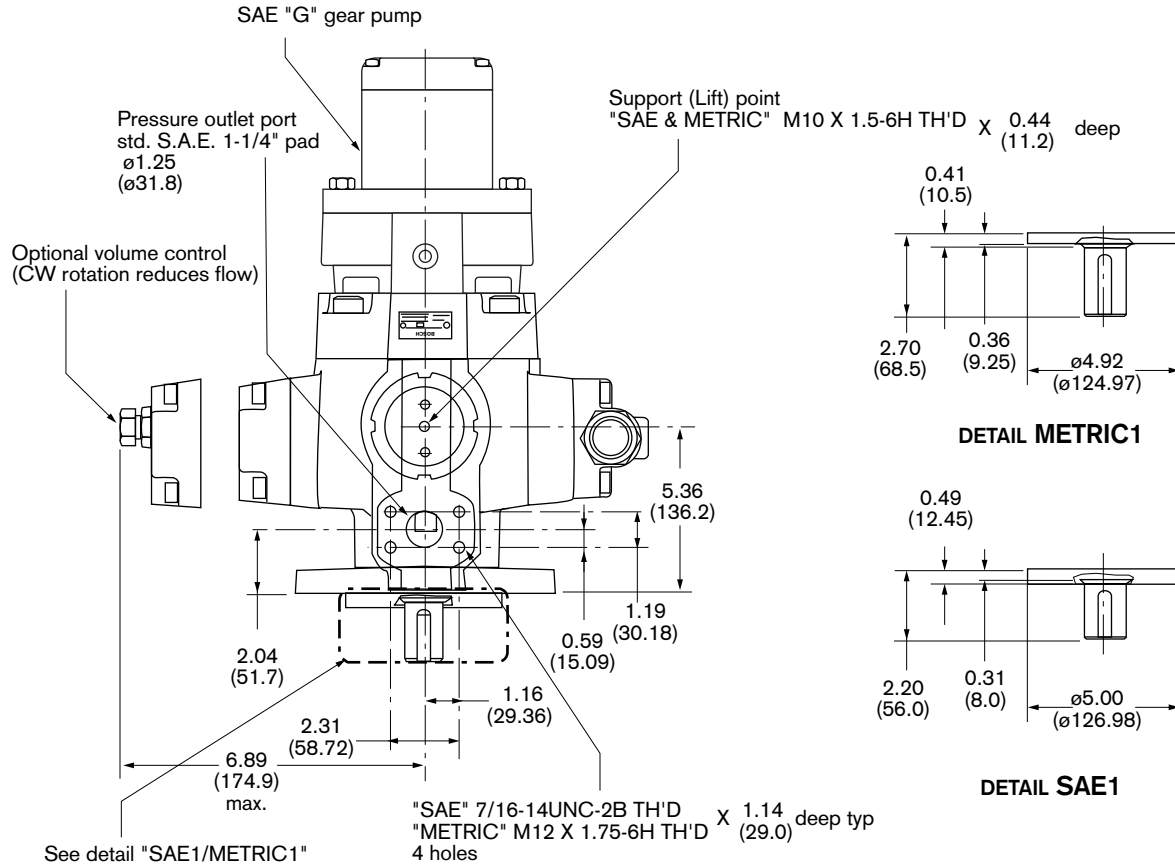

Gear pump Theoretical Displacement	Dimension				Gear Pump Port Sizes		Total Weight (Vane Pump & Gear Pump)
	A	B	C	D	Inlet	Outlet	
1.37 (22.5)	2.40 (61.0)	5.07 (128.5)	14.6 (370.8)	17.26 (438.6)	1" S.A.E. 4 bolt	3/4" S.A.E. 4 bolt	271.4 (123.1)
1.71 (28)	2.48 (63.0)	5.26 (133.7)	14.68 (372.8)	17.45 (443.2)	1" S.A.E. 4 bolt	3/4" S.A.E. 4 bolt	271.8 (123.3)
1.95 (32)	2.54 (64.5)	5.40 (137.2)	14.74 (374.4)	17.59 (446.8)	1" S.A.E. 4 bolt	3/4" S.A.E. 4 bolt	272.3 (123.5)
2.32 (38)	2.62 (66.5)	5.62 (142.6)	14.82 (376.4)	17.81 (452.3)	1" S.A.E. 4 bolt	3/4" S.A.E. 4 bolt	272.6 (123.6)
2.75 (45)	2.74 (69.5)	5.87 (149.2)	14.94 (379.4)	18.06 (458.7)	1" S.A.E. 4 bolt	3/4" S.A.E. 4 bolt	273.1 (123.9)
3.42 (56)	2.95 (75.2)	6.31 (160.2)	15.15 (384.8)	18.5 (469.9)	1" S.A.E. 4 bolt	3/4" S.A.E. 4 bolt	274.1 (124.3)

VPV 45/63/80 to VPV 45/63/80, S.A.E. & Metric Combination

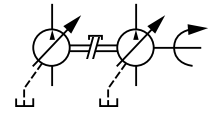

Inches (millimeters)

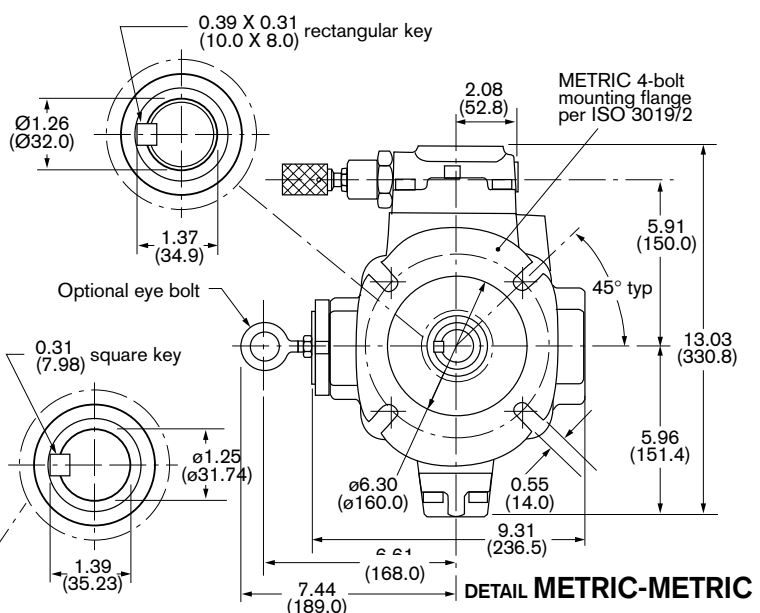
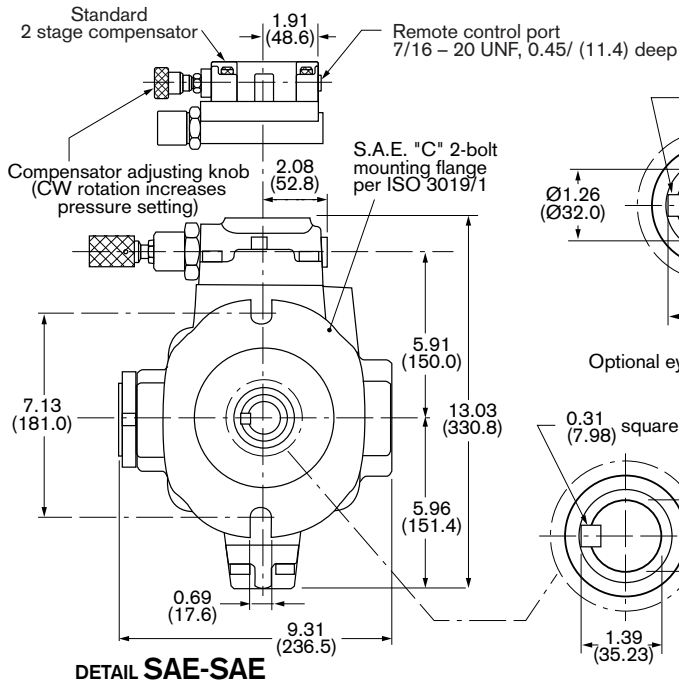
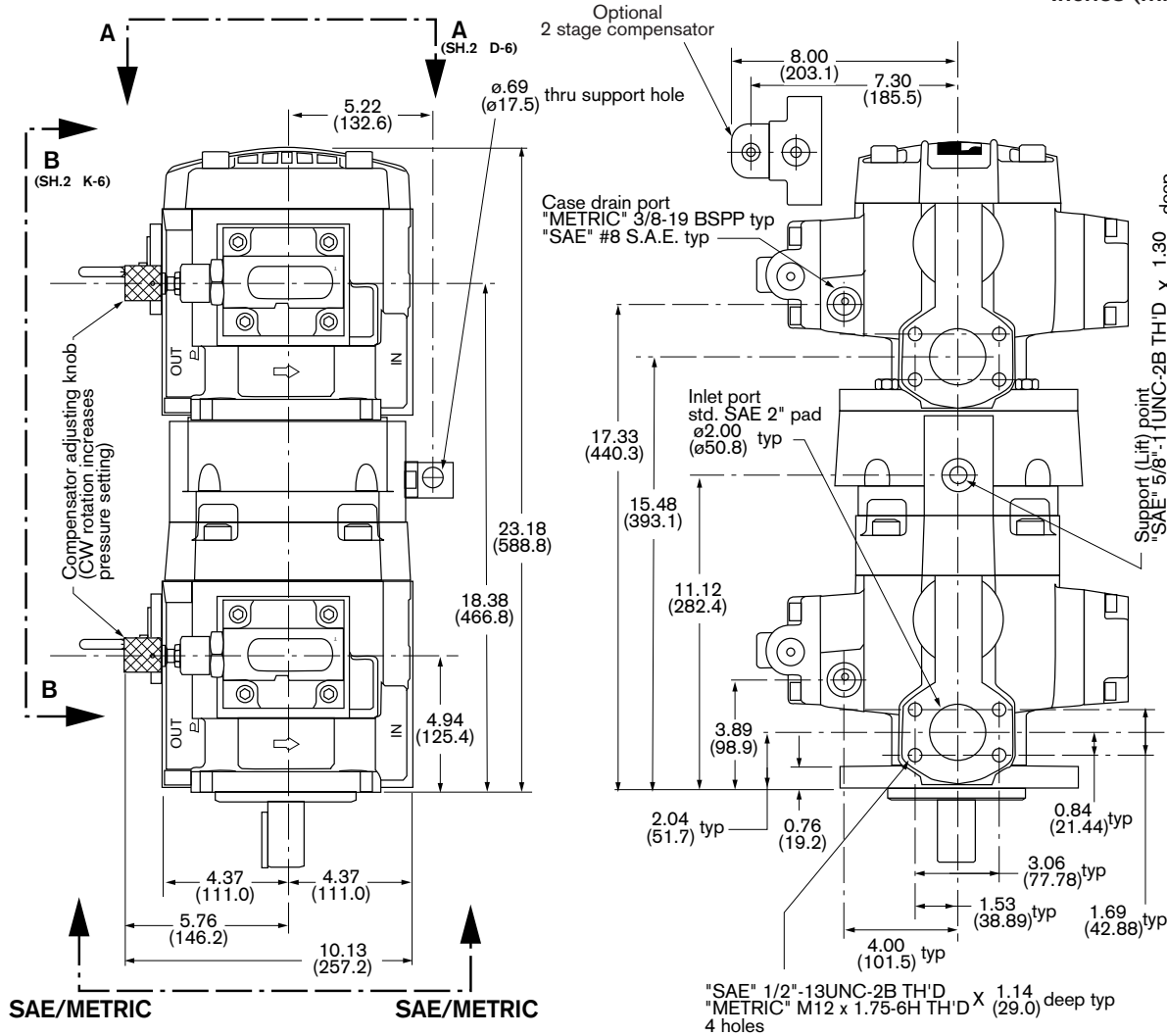

VPV 45/63/80 to VPV 45/63/80 (continued)

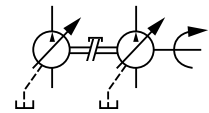

Inches (millimeters)

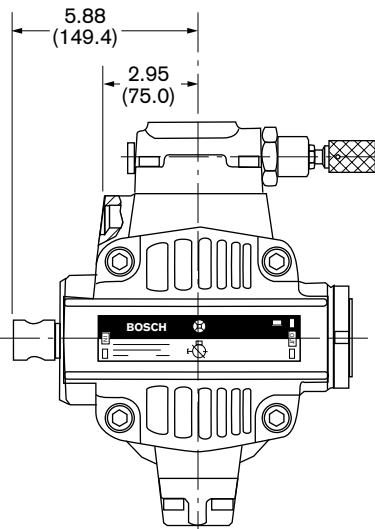

View A-A
(SH.1 @ P-2)

"SAE" 7/16"-14UNC-2B TH'D
 "METRIC" M12 X 1.75-6H TH'D X 1.14 deep typ
 4 holes

See detail "SAE1/METRIC1"

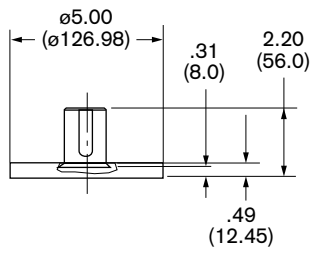
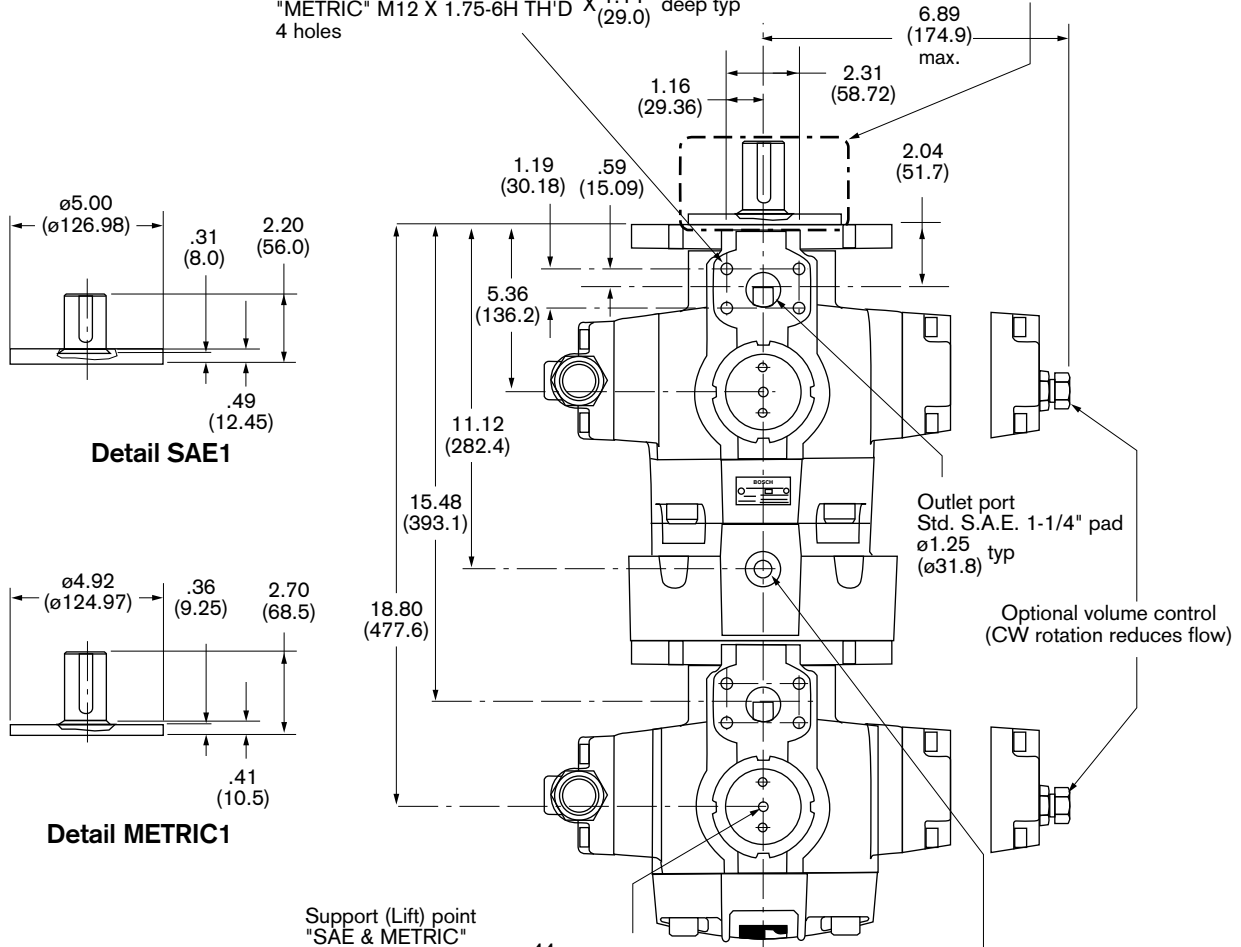

Detail SAE1

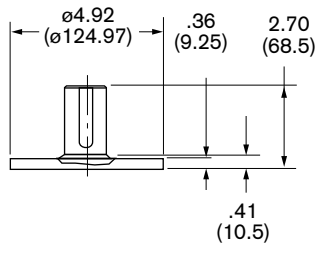

Detail METRIC1

Support (Lift) point
 "SAE & METRIC"
 M10 X 1.5-6H TH'D X .44 deep typ
 (11.2)

Support point
 "SAE" 5/8"-11 UNC-2b TH'D X 1.30 deep typ
 "METRIC" M16 x 2-6H TH'D X (33.0)

View B-B
(SH.1 @ H-2)

VPV 45/63/80 to VPV 45/63/80 (continued)

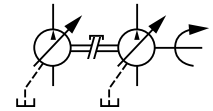

Inches (millimeters)

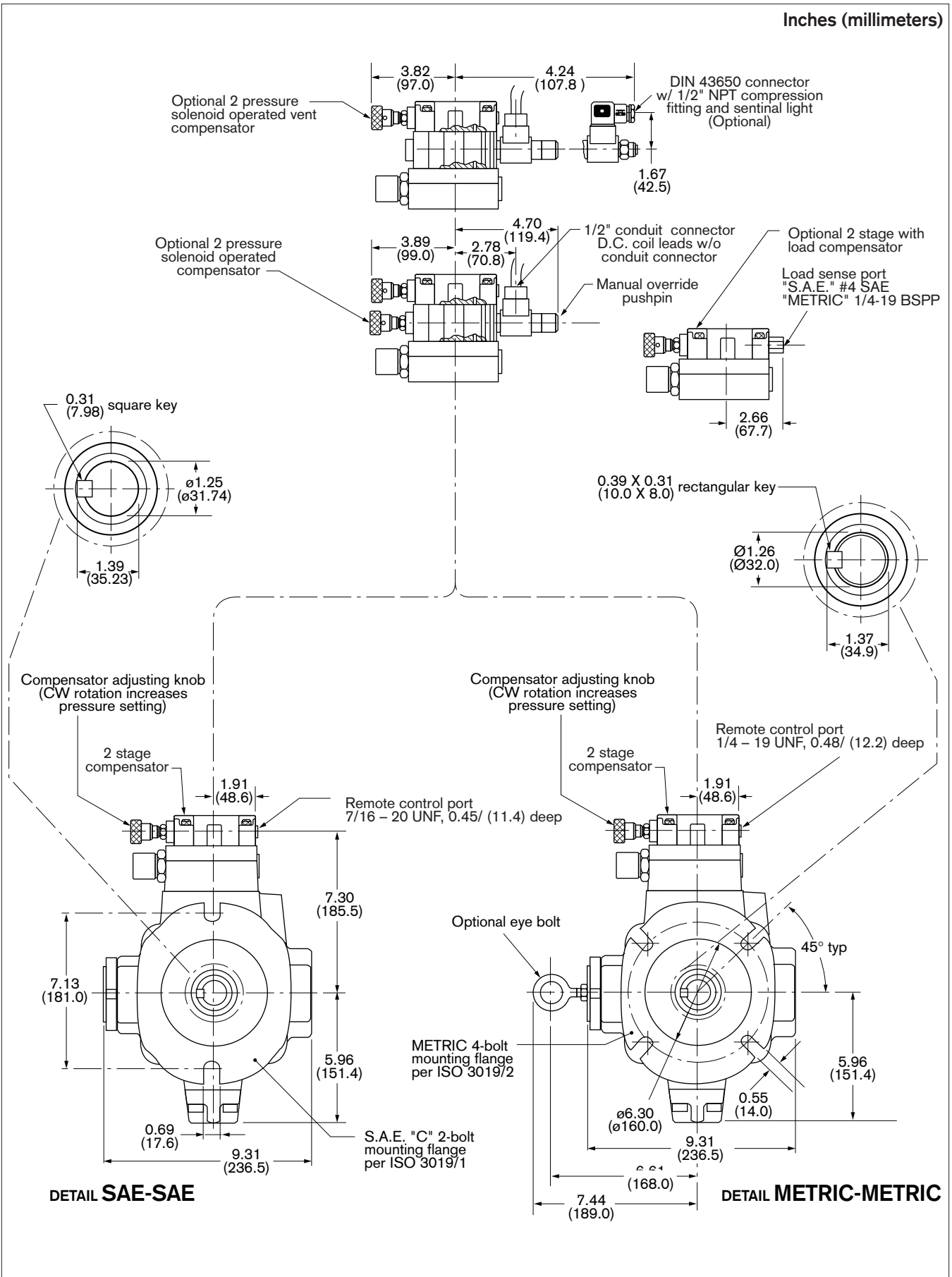

VPV 45/63/80 to VPV 45/63/80 (continued)

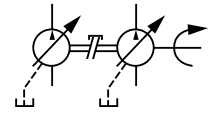

Inches (millimeters)

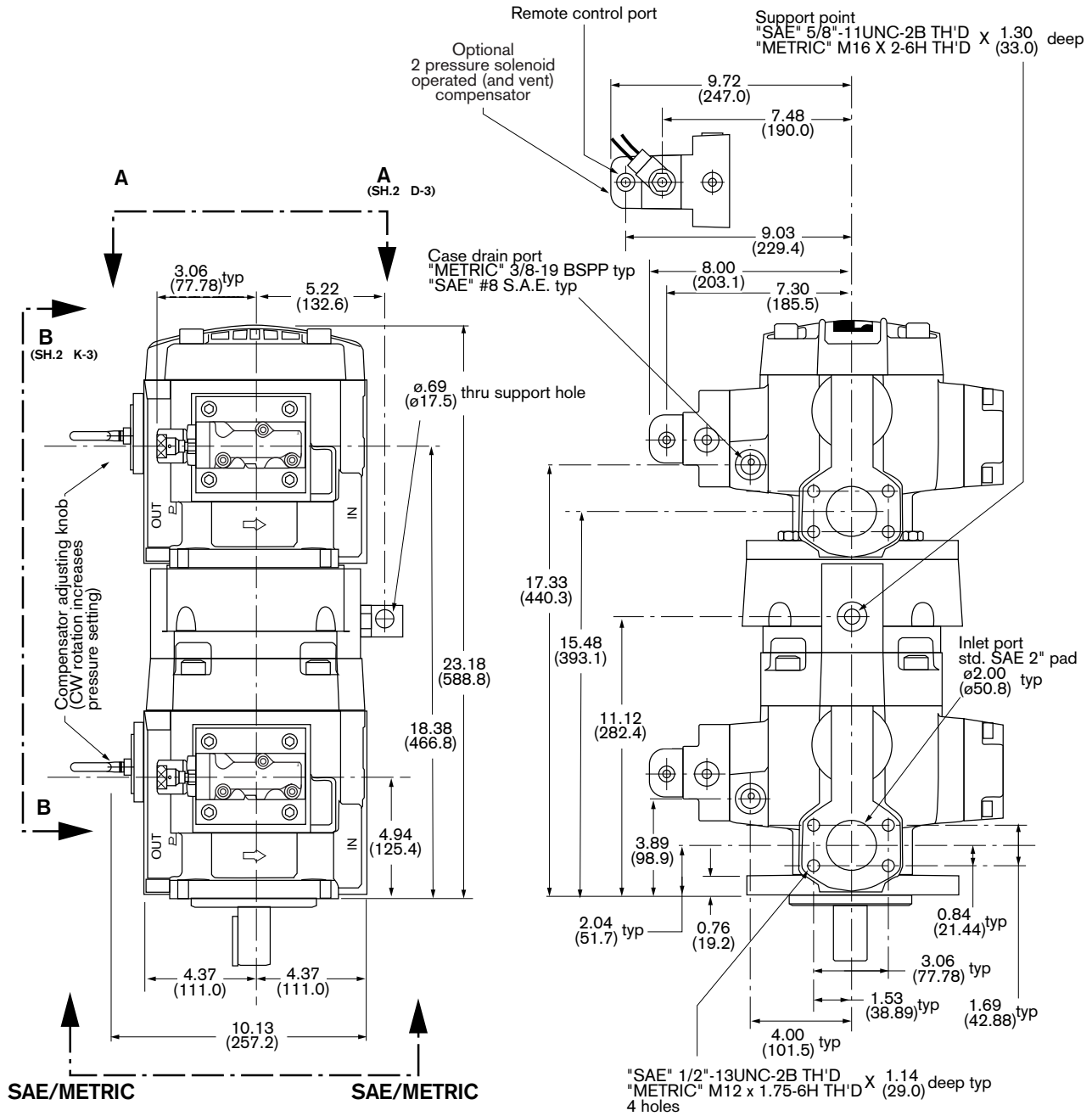

VPV 100/130/164 to VPV 100/130/164, S.A.E. & Metric Combination

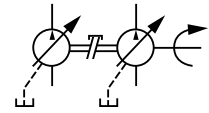

Inches (millimeters)

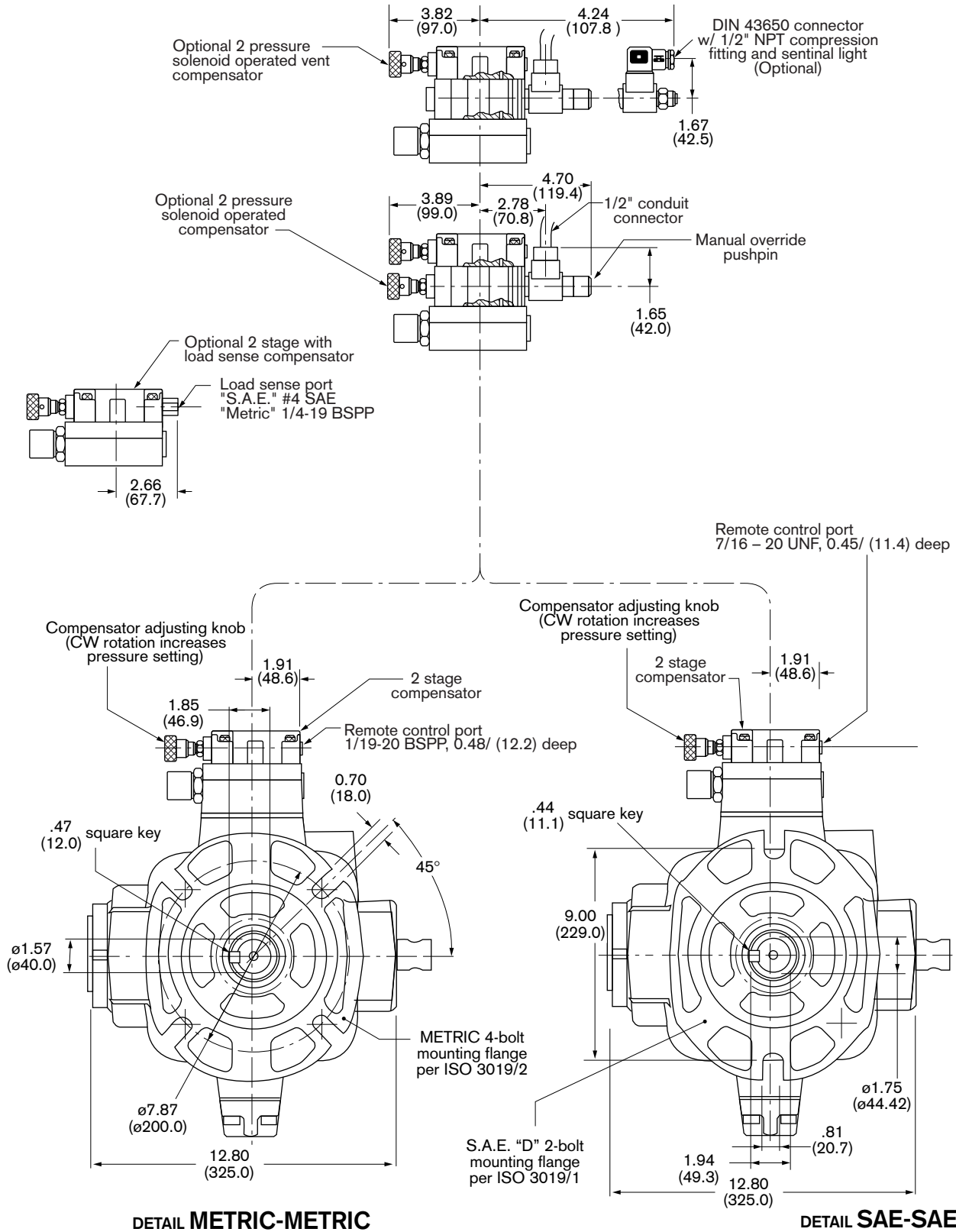

VPV 100/130/164 to VPV 100/130/164 (continued)

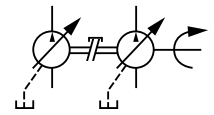

Inches (millimeters)

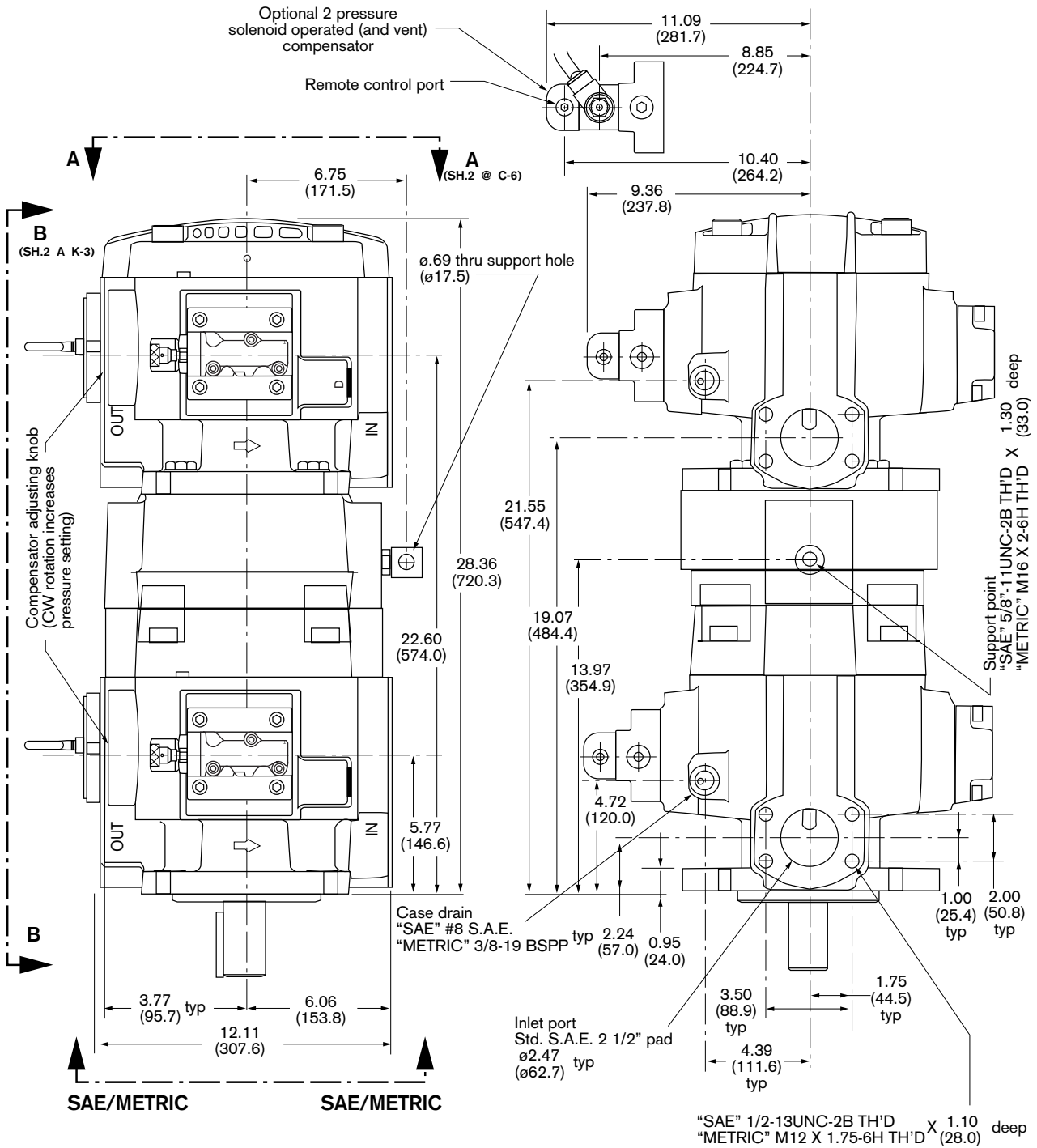

VPV 100/130/164 to VPV 16 S.A.E. & Metric Combination

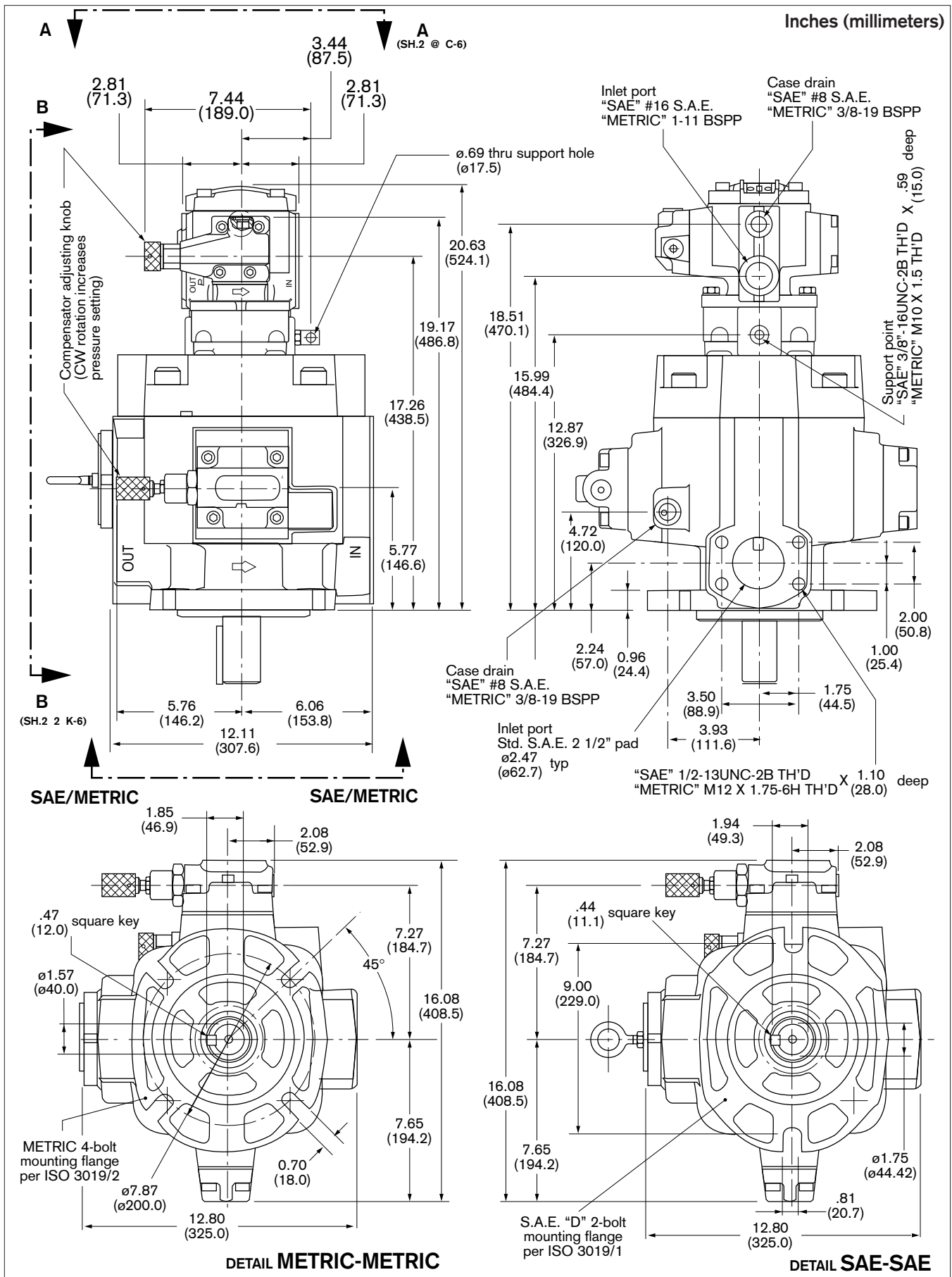
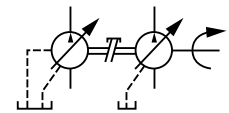

VPV 100/130/164 to VPV 16 (continued)

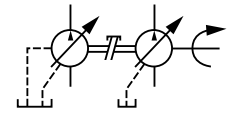

Inches (millimeters)

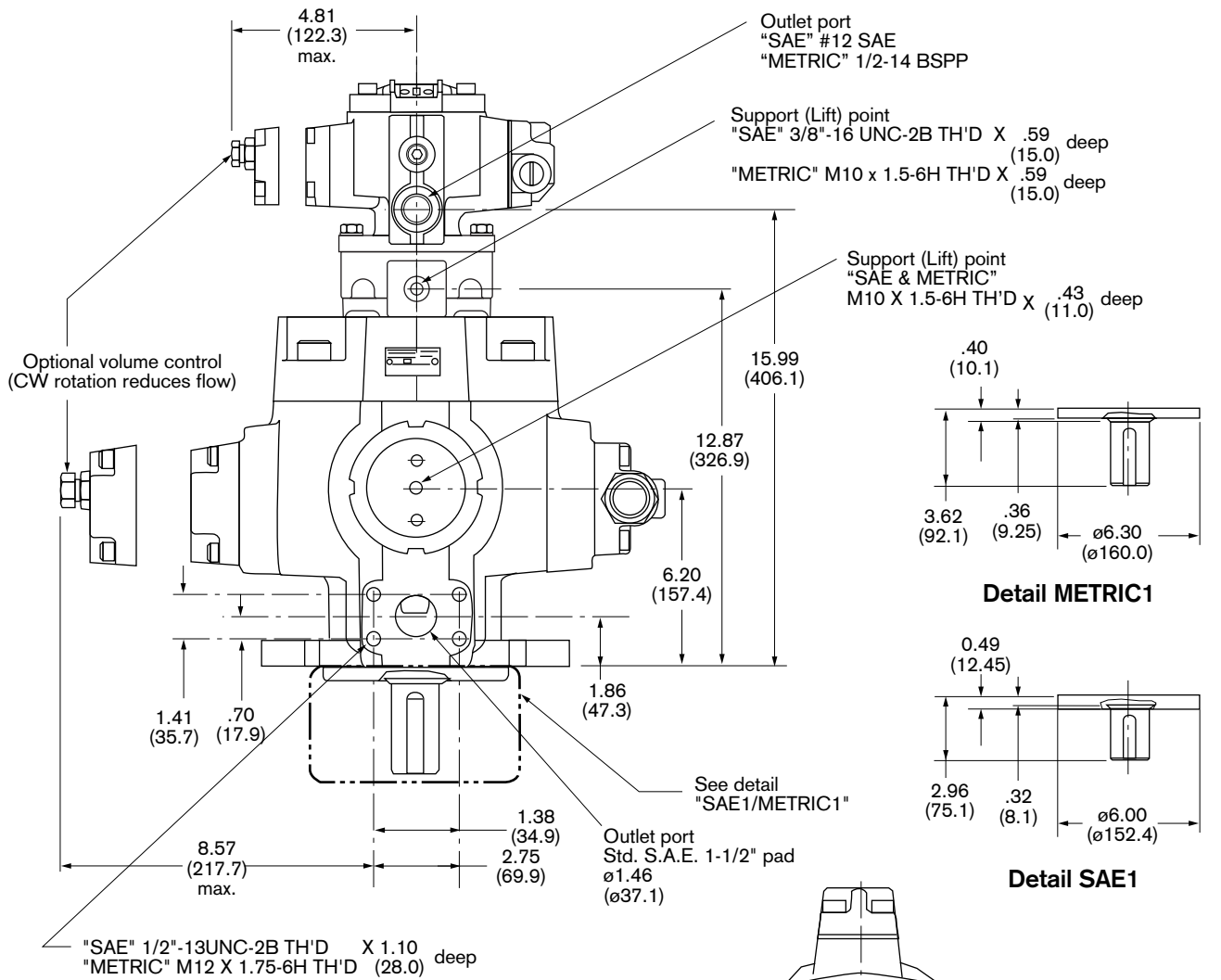

View B-B
 (SH.1 @ G-1)

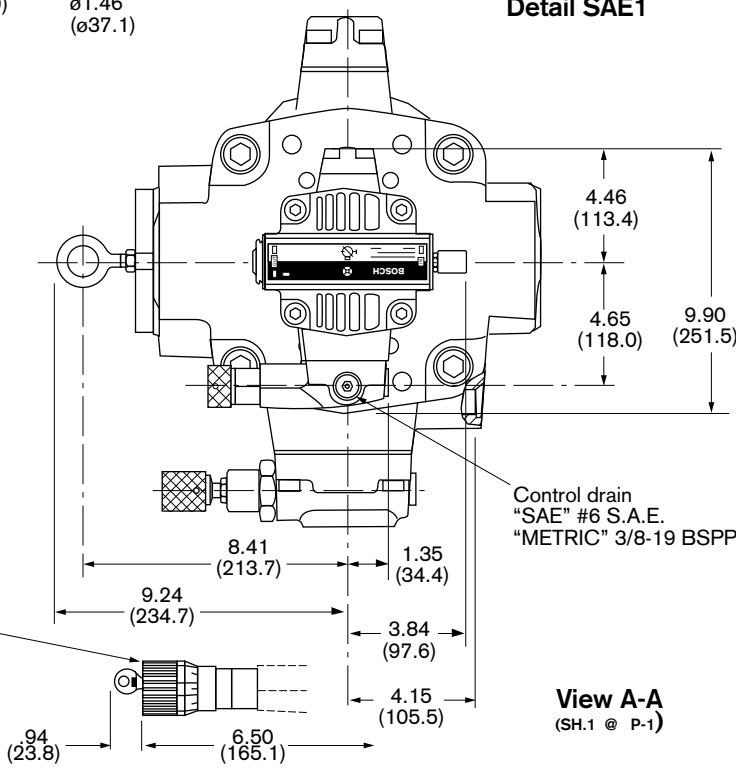

VPV 100/130/164 to VPV 16 (continued)

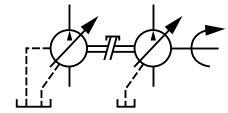

Inches (millimeters)

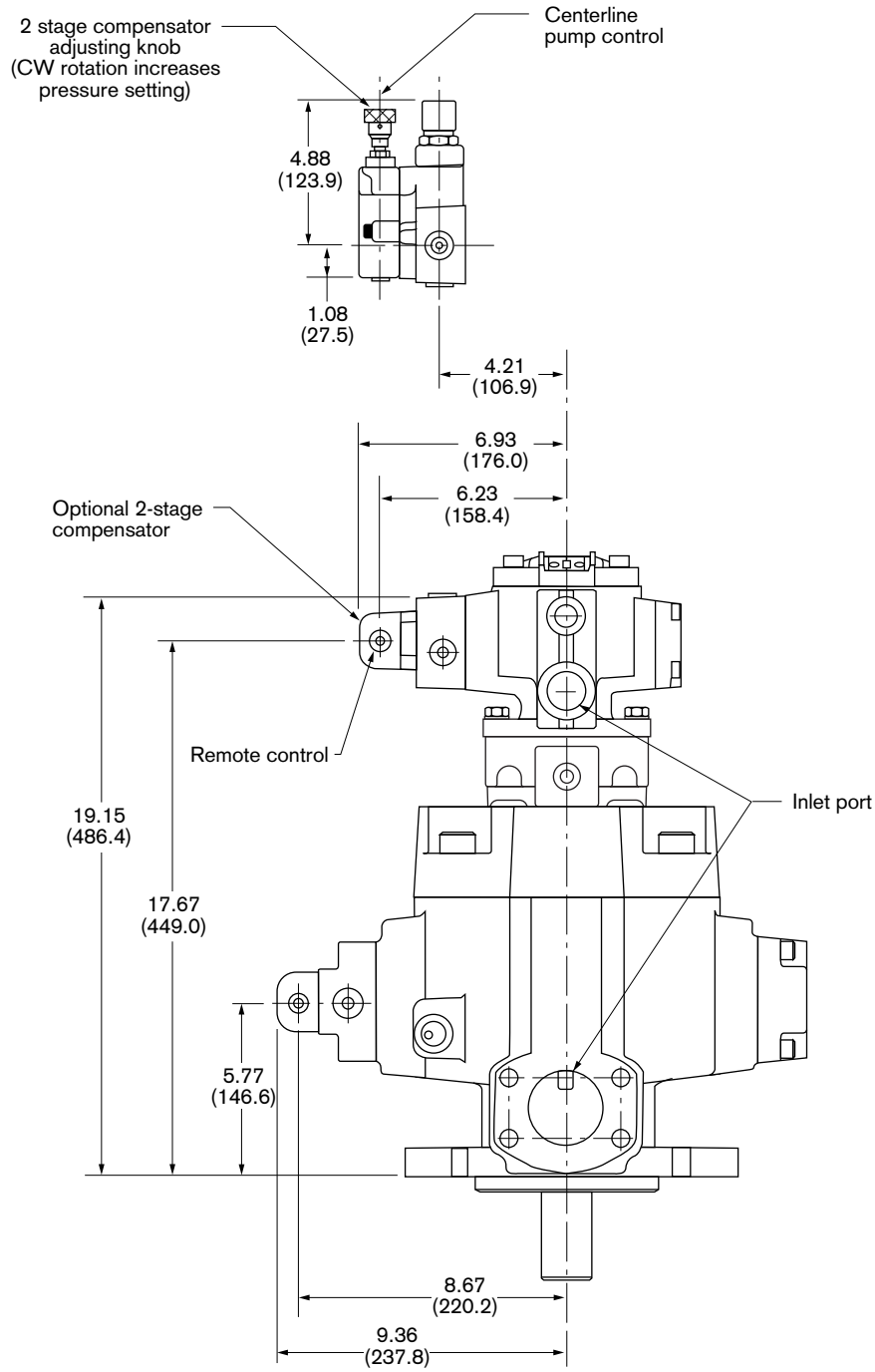

VPV 100/130/164 to VPV 25/32 S.A.E. & Metric Combination

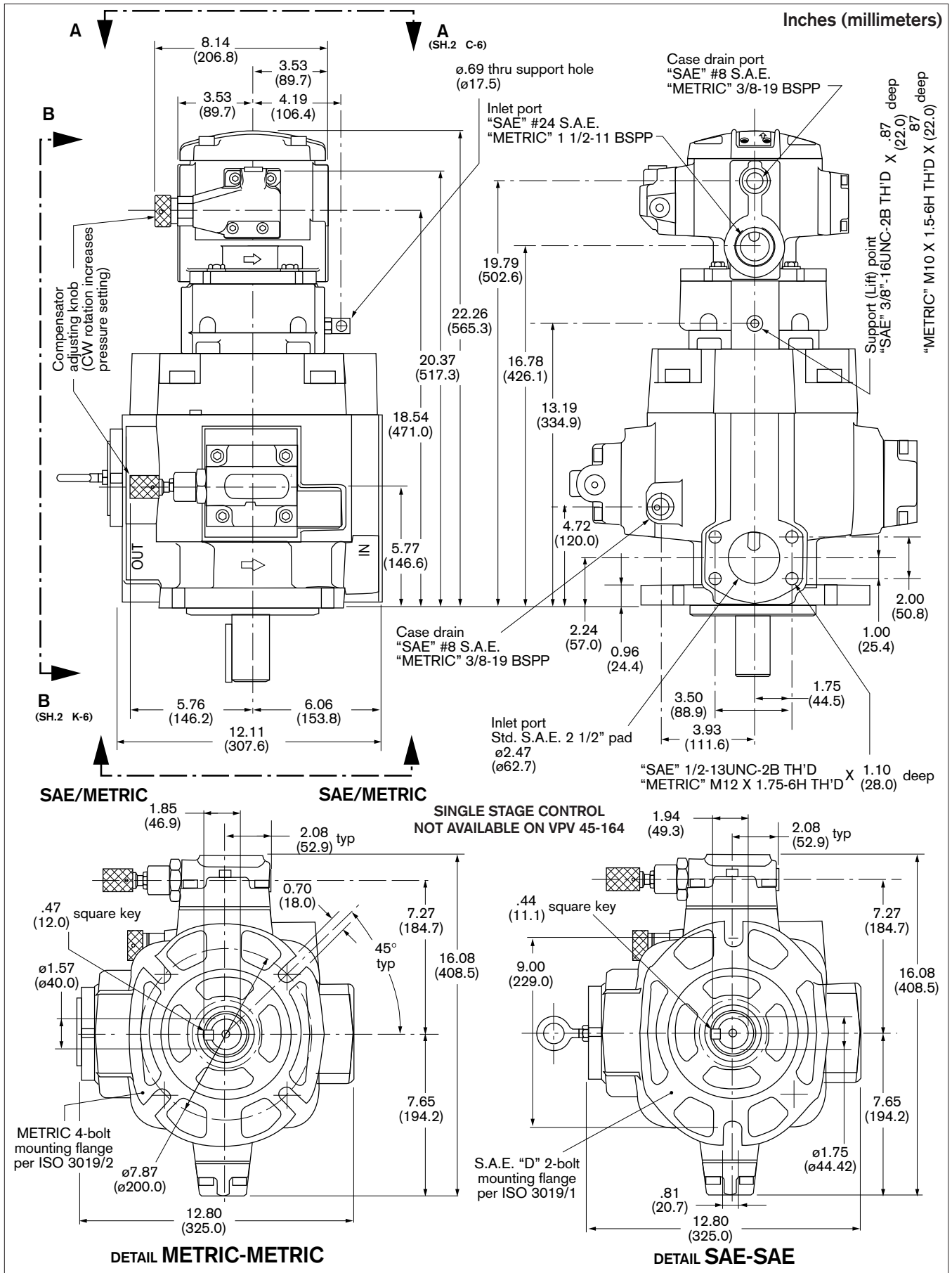
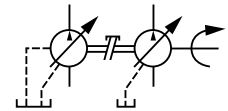

VPV 100/130/164 to VPV 25/32 (continued)

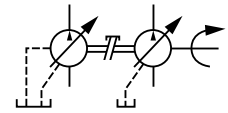

Inches (millimeters)

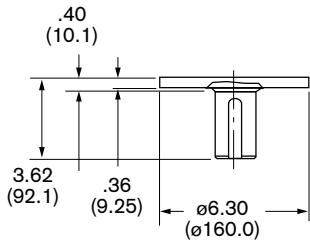
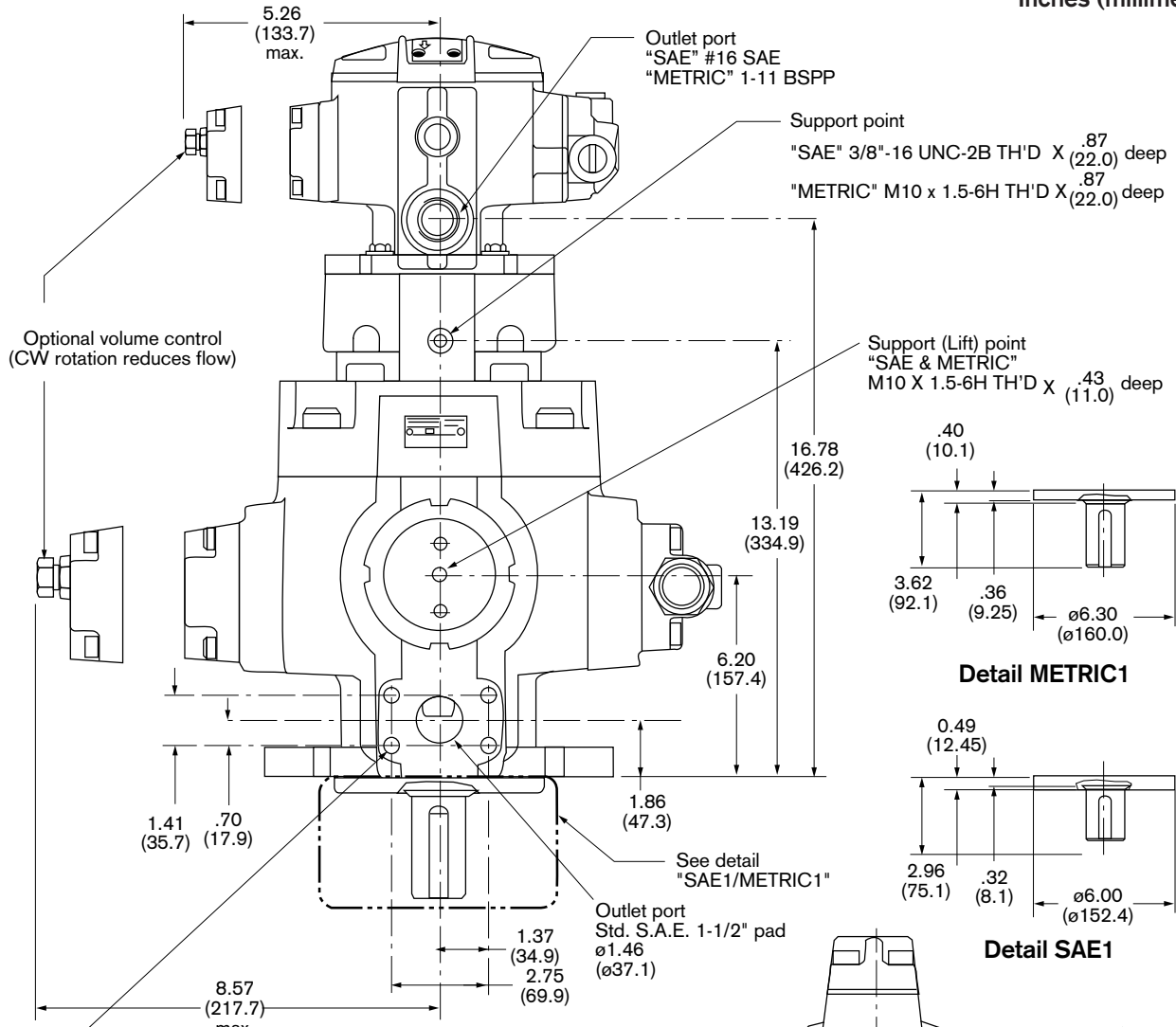

Detail METRIC1

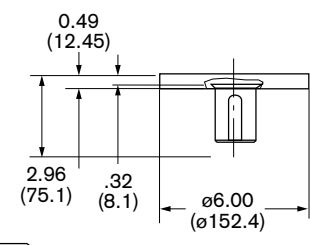

Detail SAE1

View B-B (SH.1 H-2)

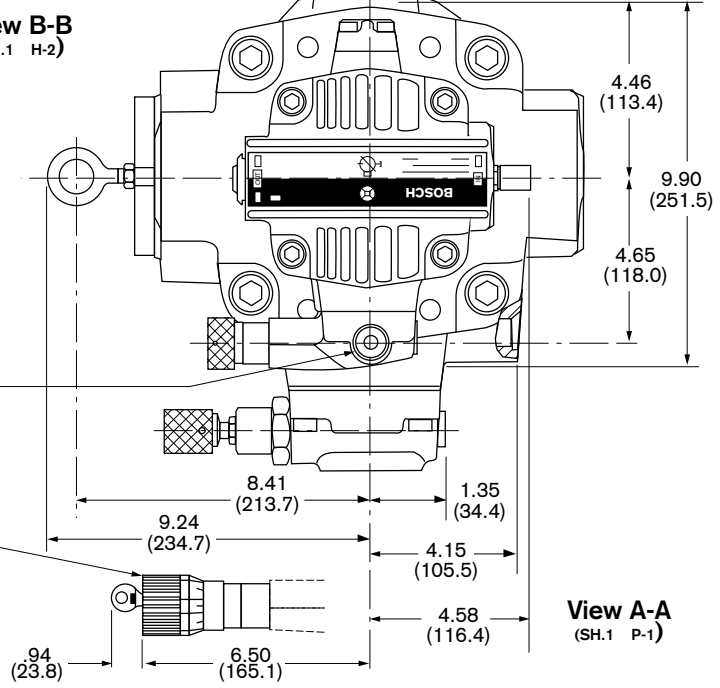

View A-A (SH.1 P-1)

Control drain
 "SAE" #6 S.A.E.
 "METRIC" 3/8-19 BSPP

Optional VPV25/32
 single stage
 compensator with
 locking device

VPV 100/130/164 to VPV 25/32 (continued)

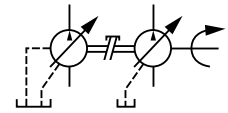

Inches (millimeters)

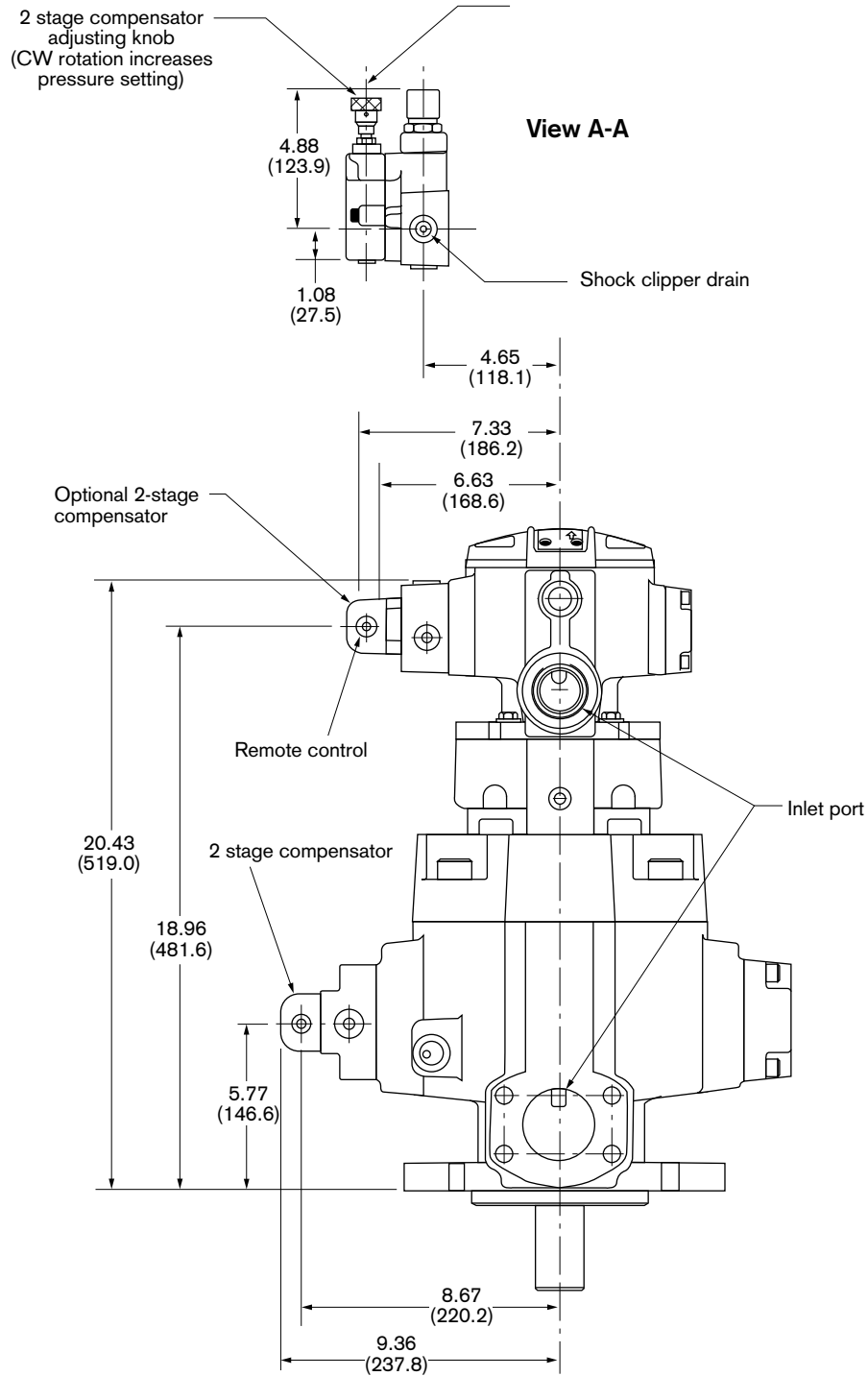

VPV 100/130/164 to VPV 45/63/80 S.A.E. & Metric Combination

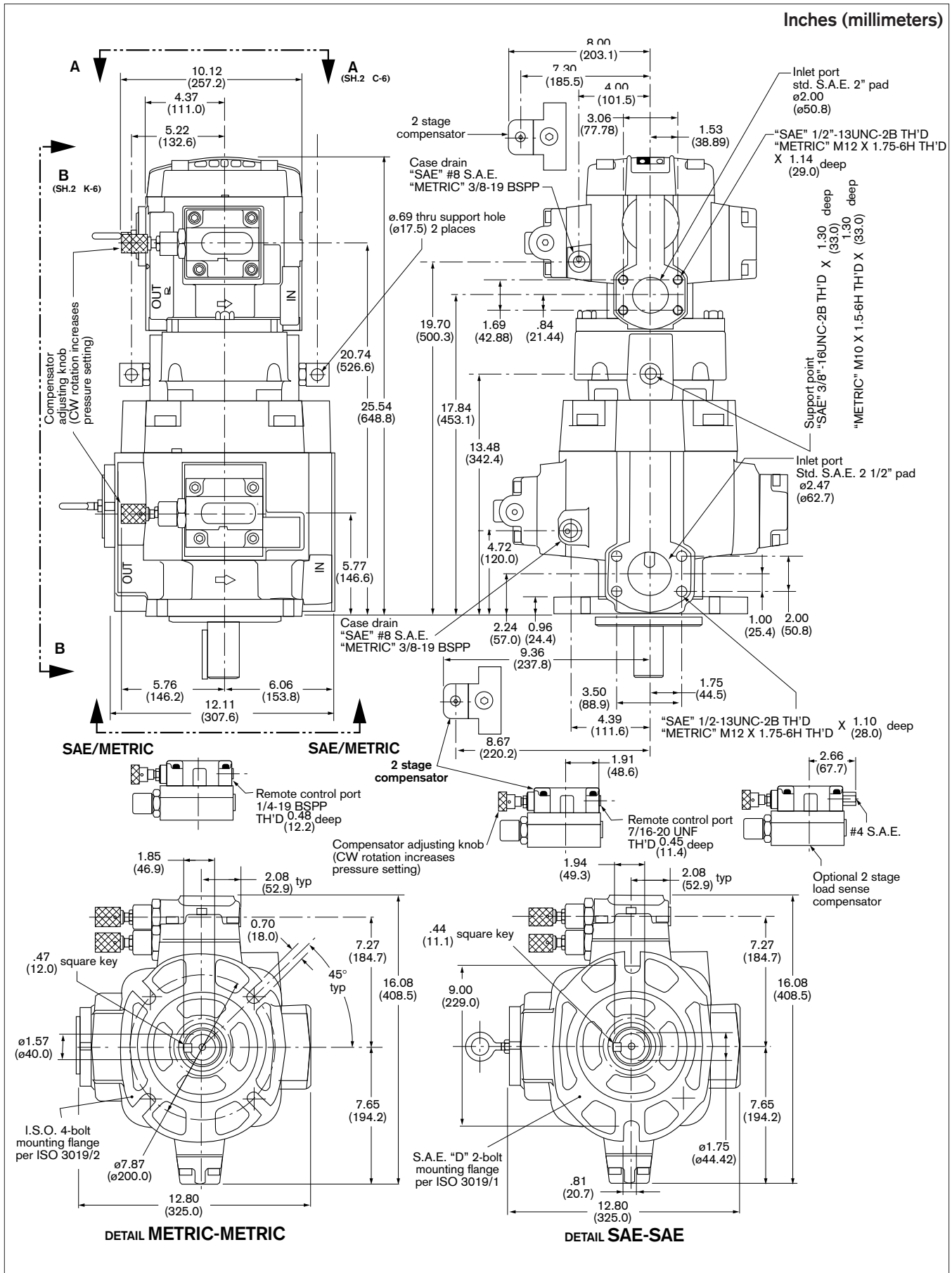
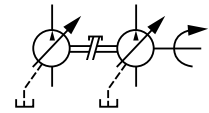

VPV 100/130/164 to VPV 45/63/80 (continued)

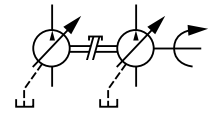

Inches (millimeters)

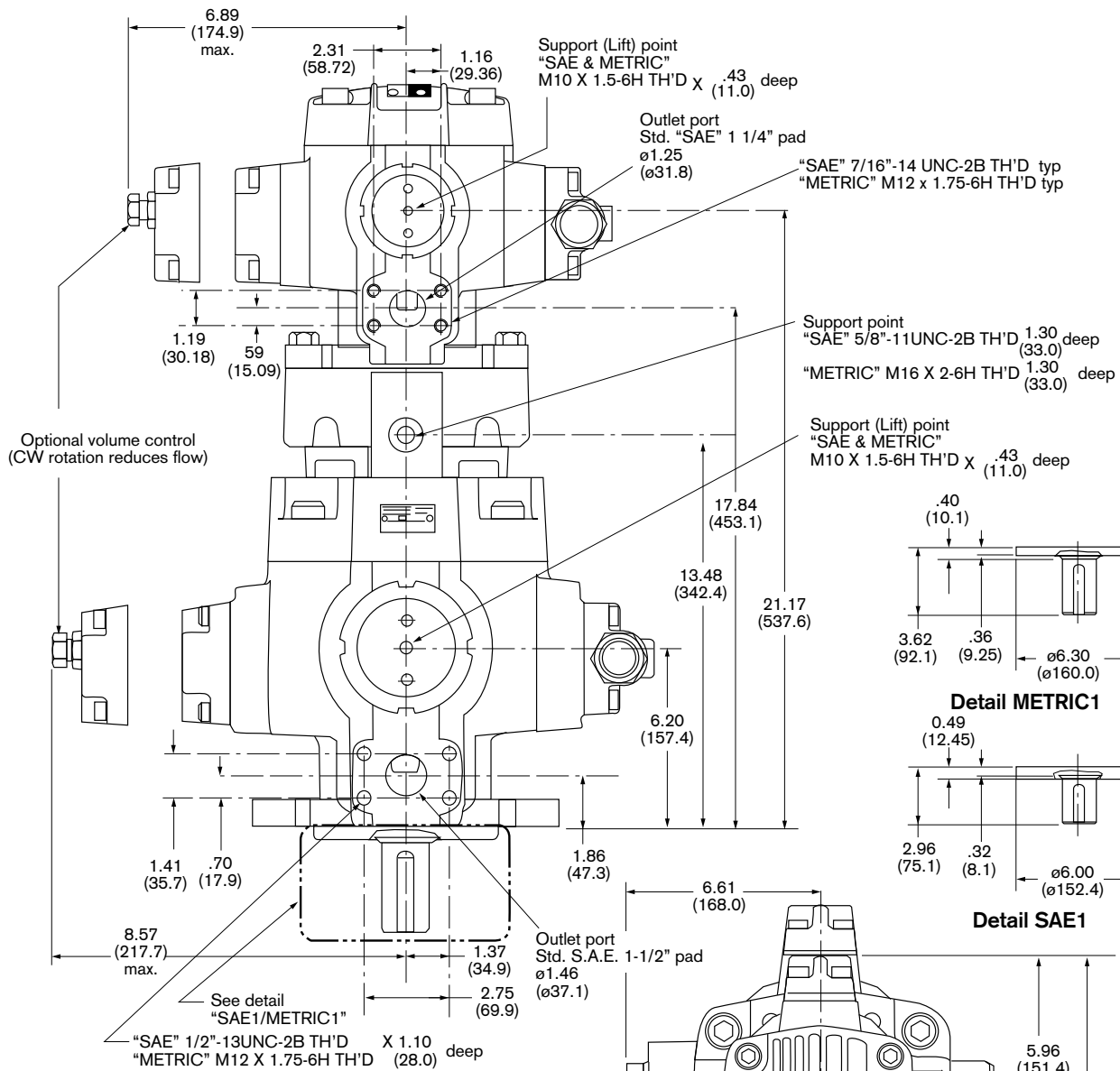

View B-B
(SH.1 @ G-1)

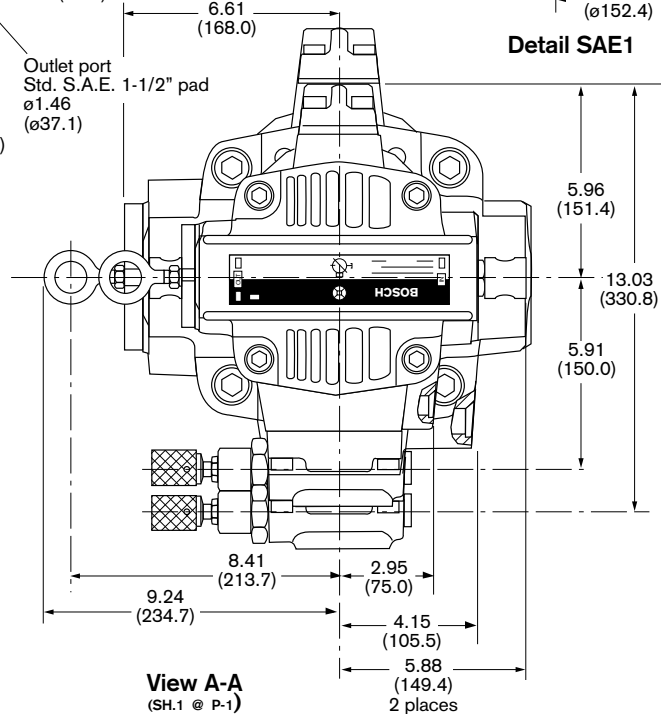

View A-A
(SH.1 @ P-1)

VPV 100/130/164 to VPV 45/63/80 (continued)

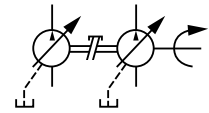

Inches (millimeters)

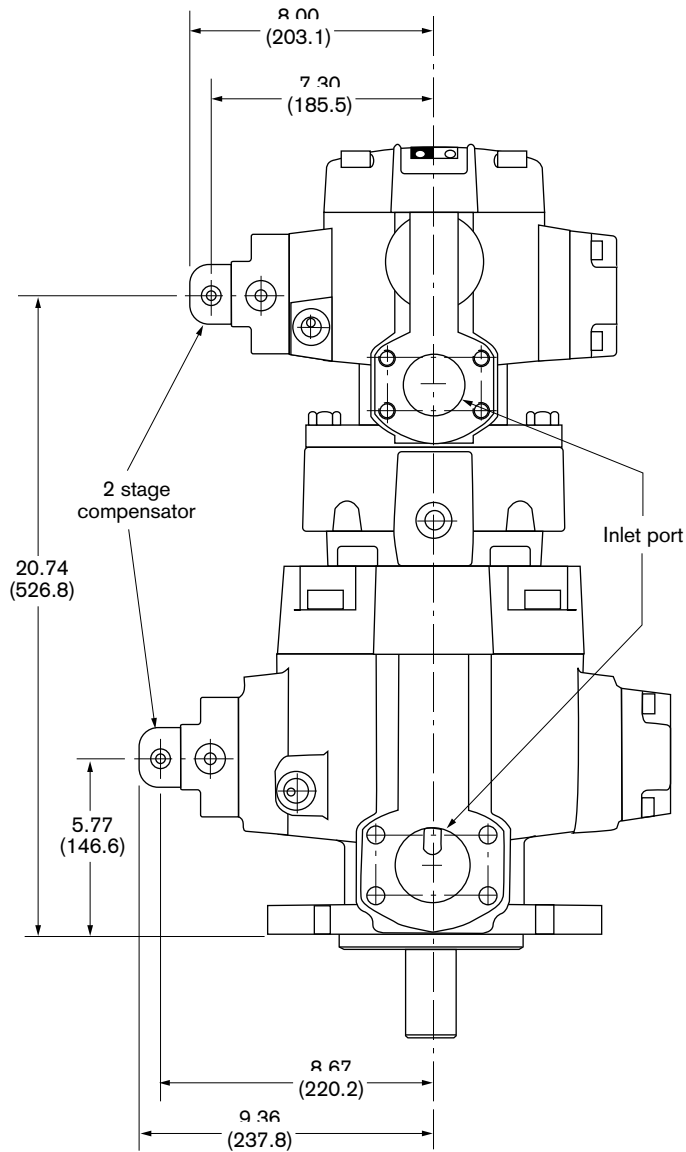

VPV 45/63/80 to an 'F' Gear pump, S.A.E. & Metric Combination

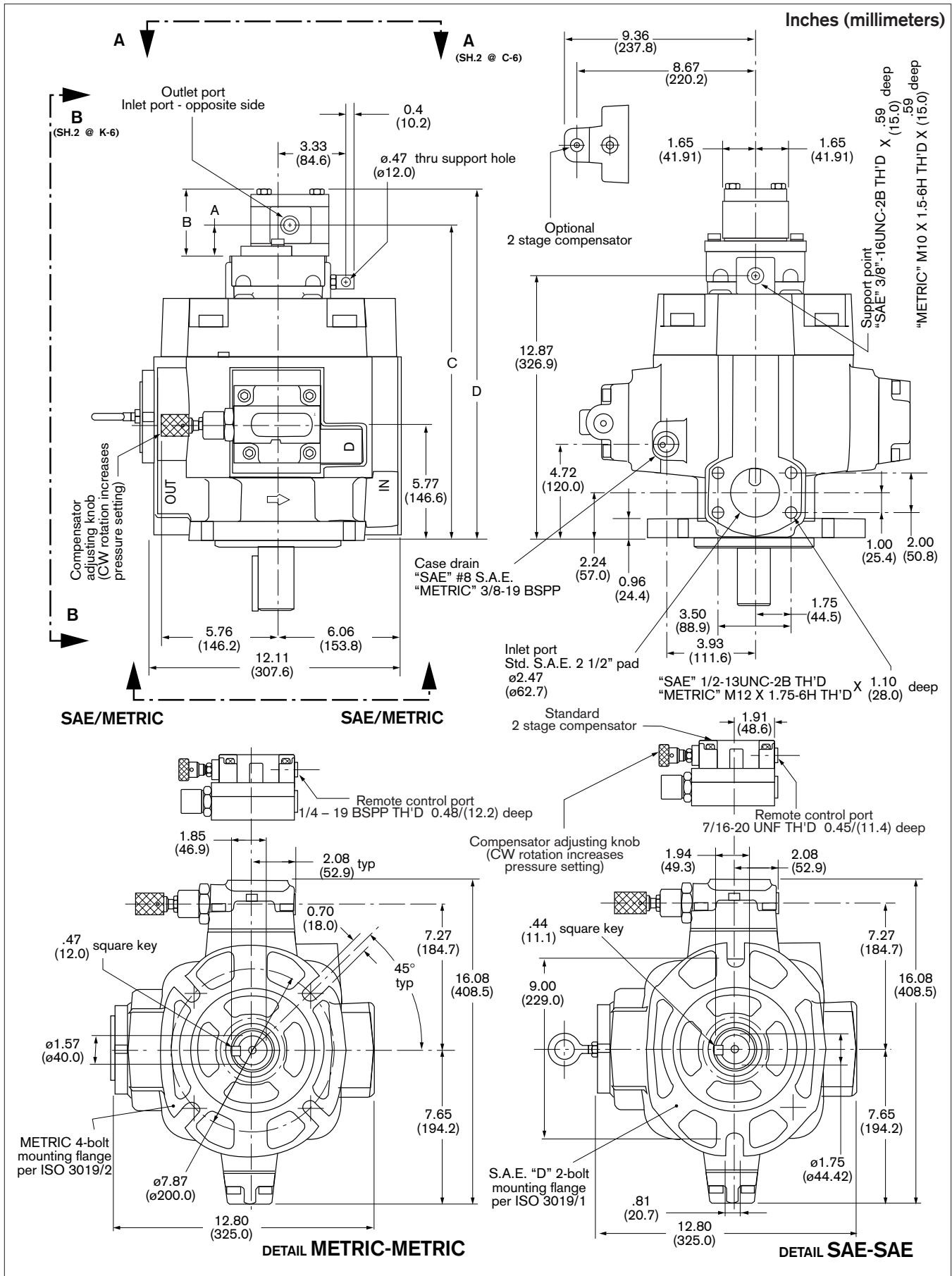
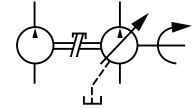

VPV 45/63/80 to an 'F' Gear pump (continued)

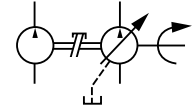

Inches (millimeters)

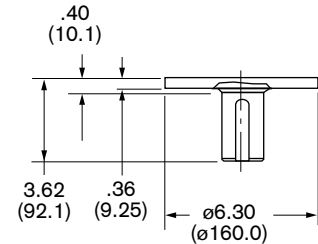
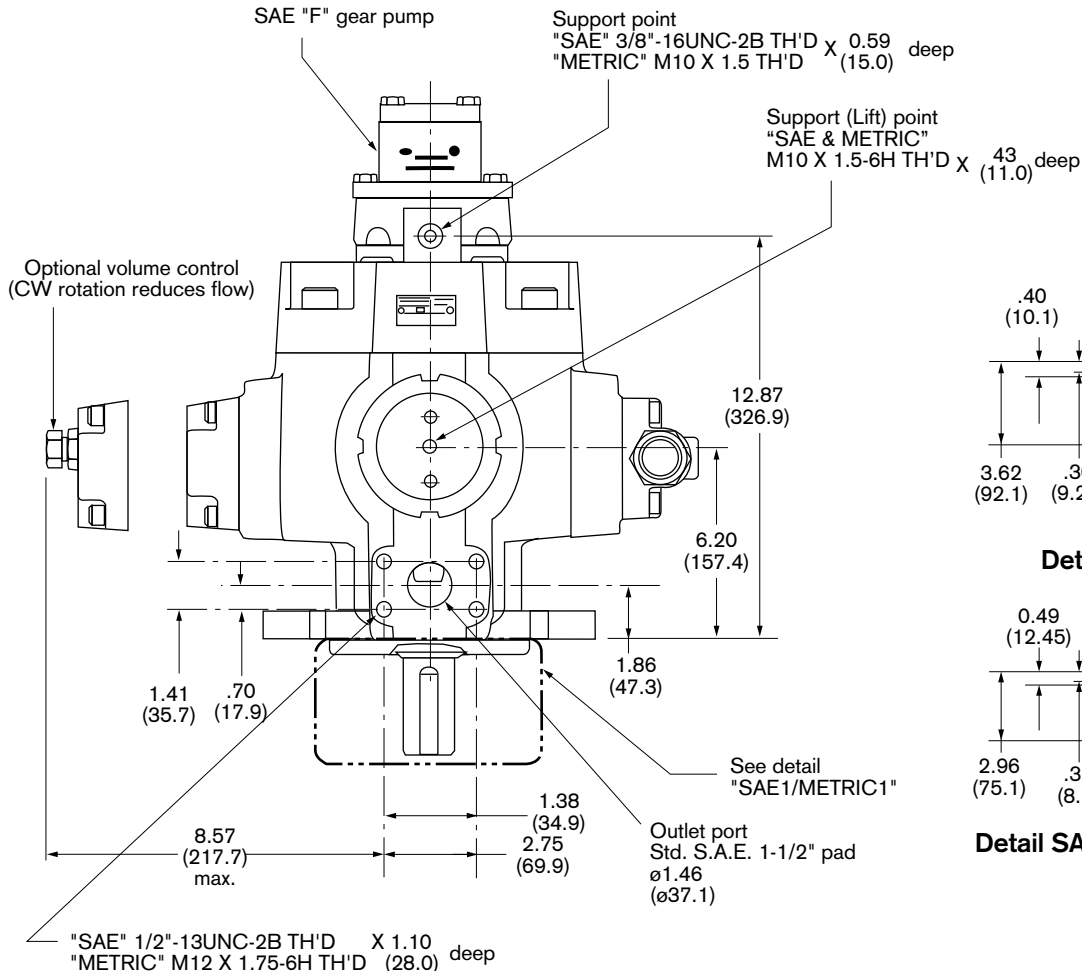

Detail METRIC1

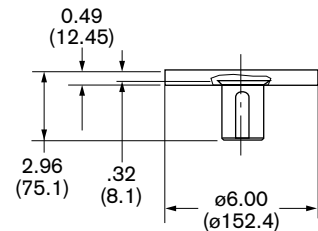

Detail SAE1

View B-B
 (SH.1 @ G-1)

View A-A
 (SH.1 @ P-1)

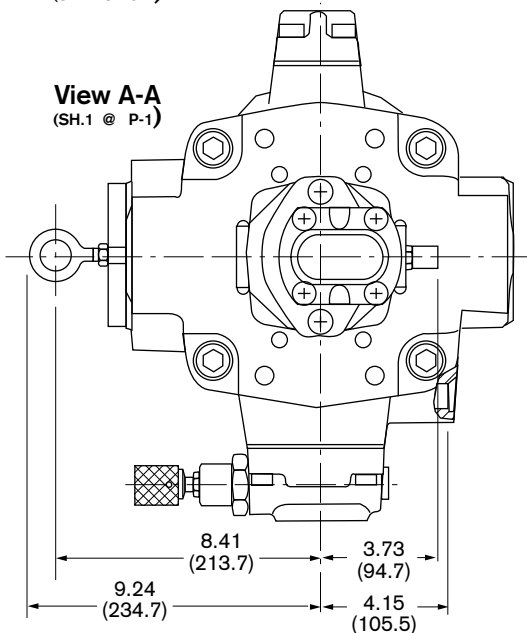

Gear pump Theoretical Displacement	Dimension				Gear Pump Port Sizes		Total Weight (Vane Pump & Gear Pump)
	A	B	C	D	Inlet	Outlet	
0.24 (4)	1.571 (39.9)	3.346 (85.0)	15.66 (397.8)	17.44 (443.2)	9/16-18 UNF	9/16-18 UNF	252 (114.3)
0.34 (5.5)	1.618 (41.1)	3.445 (87.5)	15.71 (399.0)	17.55 (445.8)	9/16-18 UNF	9/16-18 UNF	252.2 (114.4)
0.49 (8)	1.697 (43.2)	3.606 (91.6)	15.79 (401.0)	17.70 (449.6)	7/8-14 UNF	7/8-14 UNF	252.4 (114.5)
0.67 (11)	1.850 (47.0)	3.803 (96.6)	15.94 (404.9)	17.86 (453.3)	1-1/16-12 UN	7/8-14 UNF	252.6 (114.6)
0.85 (14)	1.870 (47.5)	4.0 (101.6)	15.96 (405.4)	18.05 (458.5)	1-1/16-12 UN	7/8-14 UNF	252.8 (114.7)
0.98 (16)	1.870 (47.6)	4.134 (105.0)	15.94 (404.8)	18.22 (463.0)	1-1/16-12 UN	7/8-14 UNF	252.9 (114.7)
1.16 (19)	1.870 (47.5)	4.330 (110.0)	15.96 (405.5)	18.42 (468.0)	1-1/16-12 UN	7/8-14 UNF	253.1 (114.8)
1.37 (22.5)	2.169 (55.1)	4.543 (115.4)	16.26 (41301)	18.63 (473.4)	1-1/16-12 UN	7/8-14 UNF	253.4 (114.9)

VPV 45/63/80 to an 'F' Gear pump (continued)

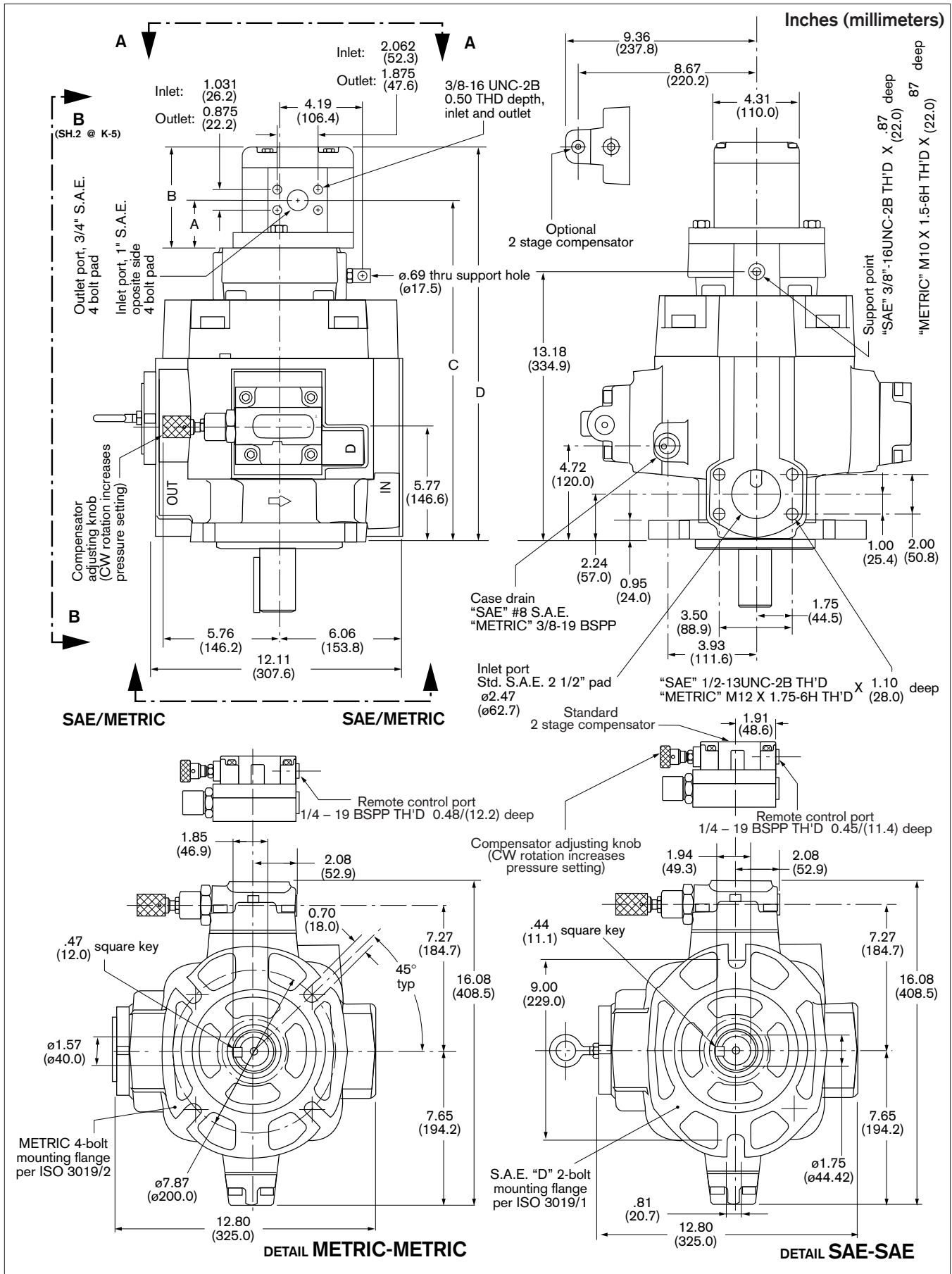
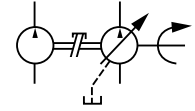

VPV 45/63/80 to an 'F' Gear pump (continued)

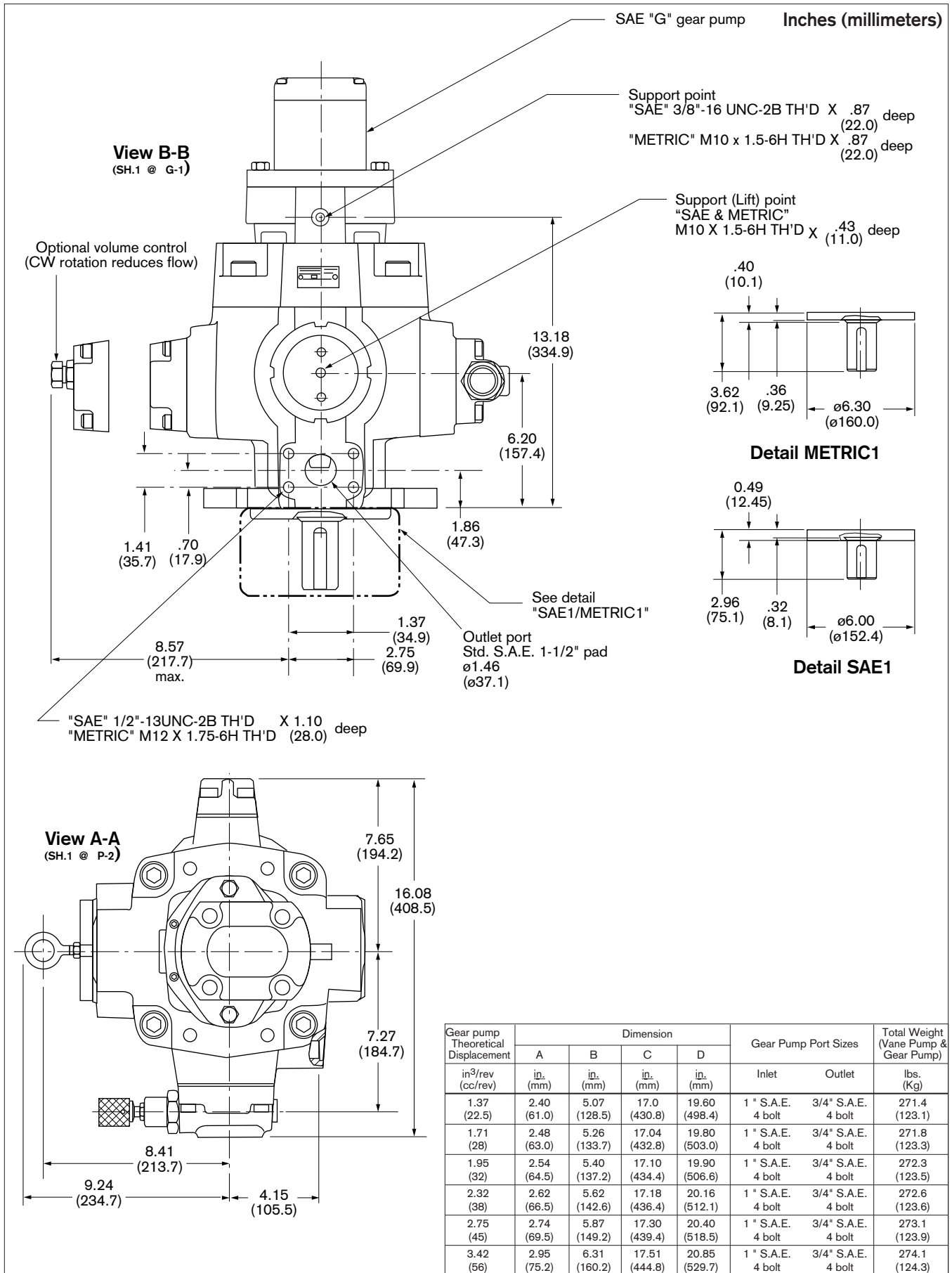
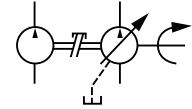

Gear pump Theoretical Displacement	Dimension				Gear Pump Port Sizes		Total Weight (Vane Pump & Gear Pump)
	A	B	C	D	Inlet	Outlet	
in ³ /rev (cc/rev)	in. (mm)	in. (mm)	in. (mm)	in. (mm)			lbs. (Kg)
1.37 (22.5)	2.40 (61.0)	5.07 (128.5)	17.0 (430.8)	19.60 (498.4)	1" S.A.E. 4 bolt	3/4" S.A.E. 4 bolt	271.4 (123.1)
1.71 (28)	2.48 (63.0)	5.26 (133.7)	17.04 (432.8)	19.80 (503.0)	1" S.A.E. 4 bolt	3/4" S.A.E. 4 bolt	271.8 (123.3)
1.95 (32)	2.54 (64.5)	5.40 (137.2)	17.10 (434.4)	19.90 (506.6)	1" S.A.E. 4 bolt	3/4" S.A.E. 4 bolt	272.3 (123.5)
2.32 (38)	2.62 (66.5)	5.62 (142.6)	17.18 (436.4)	20.16 (512.1)	1" S.A.E. 4 bolt	3/4" S.A.E. 4 bolt	272.6 (123.6)
2.75 (45)	2.74 (69.5)	5.87 (149.2)	17.30 (439.4)	20.40 (518.5)	1" S.A.E. 4 bolt	3/4" S.A.E. 4 bolt	273.1 (123.9)
3.42 (56)	2.95 (75.2)	6.31 (160.2)	17.51 (444.8)	20.85 (529.7)	1" S.A.E. 4 bolt	3/4" S.A.E. 4 bolt	274.1 (124.3)

VPV Controls

Schematics shown illustrate VPV 45–164 controls with shock clipper integrated and no exterior plumbing required. The case drain shows an integrated check valve not present in VPV 16, 25 and 32. All controls leave the factory pre-set at 500 PSI.

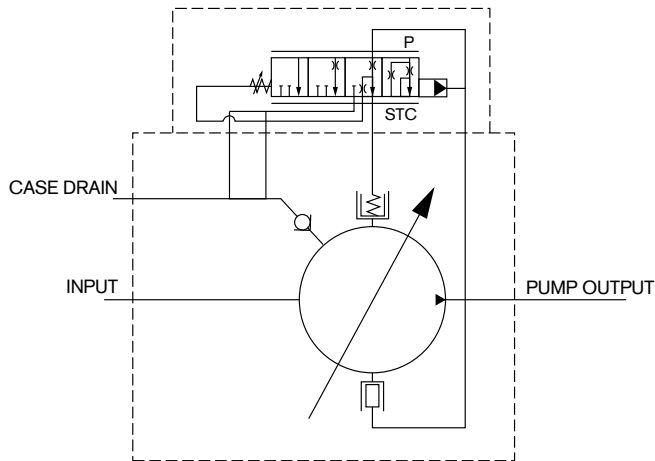

Single Stage Compensator

The single stage control for normal pressure compensation is a good choice where speed is important and remote capability is not required. This control is available on VPV 16, 25 and 32.

Two Stage Compensator

The two stage pressure compensators are the platform for most VPV controls. A remote port is standard and may, or may not be enabled according to the circuit design. This is the smoothest of the standard pressure controls, and is the standard pressure compensator for VPV 45–164.

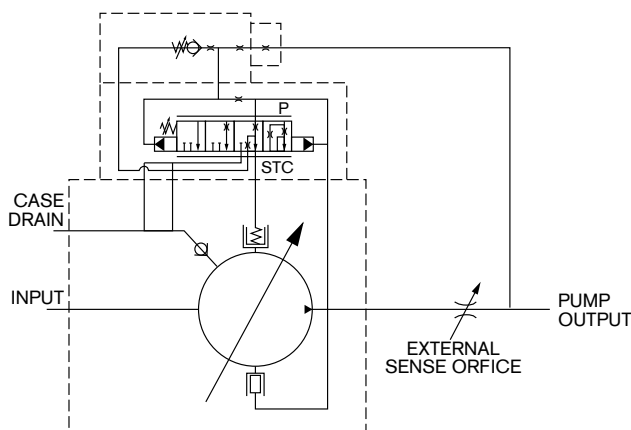
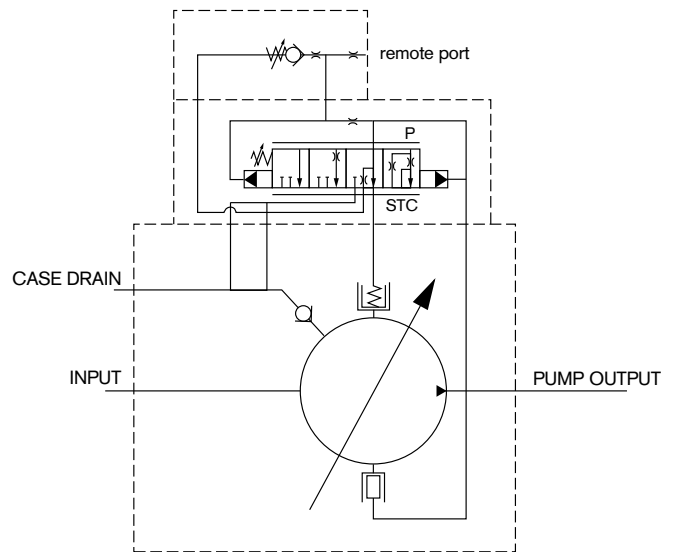

Load Sense Compensator

Load sense allows the user to maintain constant flow regardless of changes in load or in pump shaft rotational speed. The Whisper™ Pump load sense accomplishes this by using an external orifice and continually senses a pressure drop of 100 PSI across this orifice. The minimum ΔP is 200 PSI, however the pressure drop can be adjusted to meet circuit requirements. Consult factory.

VPV Controls (continued)

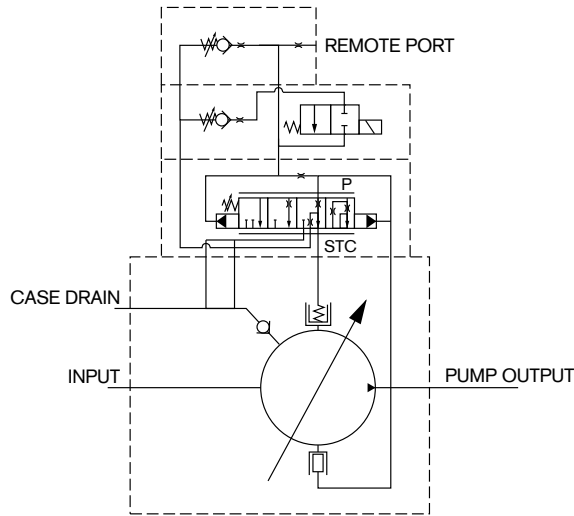

Two Pressure Compensator

Solenoid two-pressure compensators are available in normally open (normally low, energize to high) and normally closed (normally high, energize to low) versions. These two-pressure controls can greatly reduce horsepower demand and heat generation during periods of idle cycle time, or when the machine operating cycle does not require maximum pressure.

Solenoid Vent Compensator

Solenoid vented compensators are similar to the two-pressure controls, except that there is no adjustment possible. By venting the compensator the pump will go to minimum deadhead.

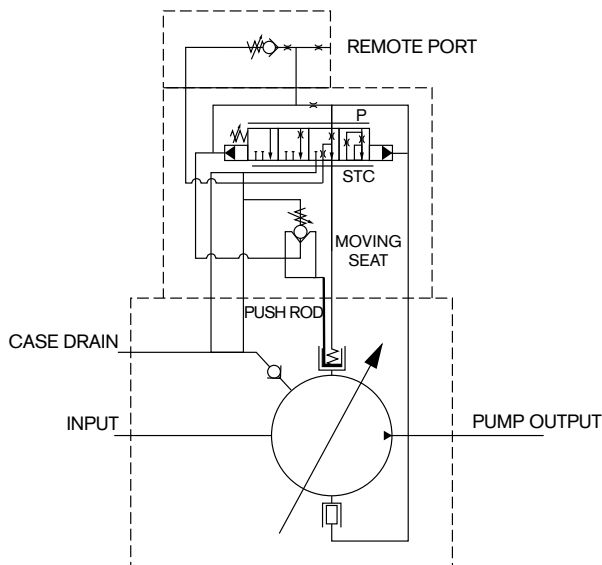
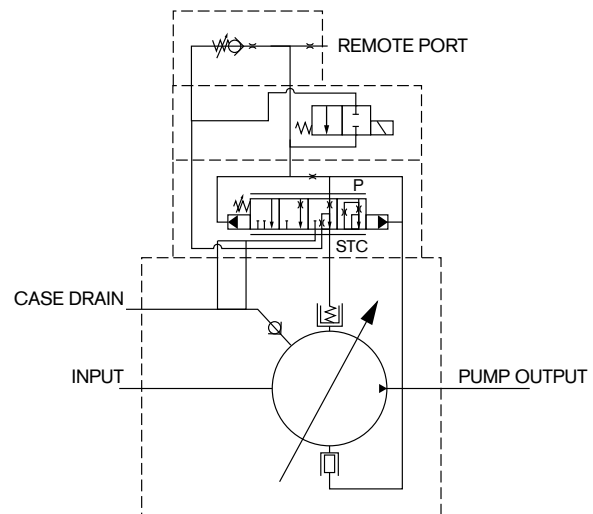

Torque Limiting Compensator

Torque limiting for VPV limits the input torque to the pump shaft, in effect limiting the horsepower transmitted to the load. No torque or horsepower sensing is done on the load, only at the pump itself. Pump output flow rate is linear and proportional to movement of the pressure ring. This compensator is adjustable in the field as torque vs. flow requirements demand. Consult factory for adjustment procedure.

Comparison of Sound Levels

Source of Sound	Intensity (dB)	
Threshold	0	
Rustling leaves	10	Barely audible
Broadcast studio	20	
Typical bedroom at night	30	Very quiet
Typical living room	40	
Office, classroom	50	← VPV16 @ 1200 rpm & 500 psi, deadhead (49 dB)
Normal conversation	60	Moderate
Automobile interior	70	
Urban street	80	← VPV130 @ 1800 rpm & 3000 psi, full flow (76 dB)
Heavy truck (15 m)	90	Very noisy
Shout (1.5 m)	100	
Construction site	110	
Loud rock music	120	Threshold of pain
Jet airplane	150	Intolerable
Rocket engine	180	

Trouble Shooting for VPV “Whisper Pumps™”

Some of the most common difficulties that could be experienced in the field are listed here with potential causes and their remedies.

TROUBLE	POTENTIAL CAUSE	REMEDY
Excessive pump noise	1) Coupling misalignment	1) Align the pump and motor shaft to within .006 of an inch total indicator reading. The tighter the alignment, the quieter the pump will be.
	2) The continuous pressure is significantly below 200 psi for 140 bar pumps, or 300 psi for 210 bar pumps.	2) The pumps have been sound tuned at rated pressure. Consult factory or raise minimum pressure 200 psi for single stage compensators in 2000 psi rated pumps, or 300 psi for 3000 psi rated pumps.
	3) Fluid in the reservoir is low and the pump is sucking air.	3) Fill the reservoir so that the fluid level is well above the end of the suction line during all of the working cycle .
	4) Restricted inlet.	4) If a suction strainer is used, check it for obstructions or dirt. We do not recommend the use of strainers as they tend to be a leading cause of cavitation which manifests as excessive noise. Check also for shop rags left in the reservoir.
	5) Air leak in the suction line.	5) Tighten all fittings. If it still leaks, smear grease over the joints to locate the leak.
	6) Suction line has too many elbows, or is too long.	6) The suction line should be as short and as straight as possible to reduce the resistance to flow.
	7) Air in the fluid.	7) The return line should terminate below the fluid level to prevent splashing.
	8) Suction line is too small.	8) Suction line should always be equal in size to the suction port. Never reduce it.
	9) Vane does not move freely.	9) Contamination in the fluid or a burr in the vane slot can cause a vane to bind up. Proper filtration and/or deburring of the vane slots is required.
	10) Vane is installed incorrectly.	10) In vane pumps built up to and including SV series 62 and VPV series 00 and A02, vanes must be mounted with the rounded edge toward the ring. In SV series 72 and VPV series B01 and later, the leading edge of the vanes must be oriented in the direction of rotation. The leading edge is identified as the low side of the vane taper.
	11) A vane is missing.	11) Make sure all vane slots have a vane in them.
	12) Port plates installed incorrectly.	12) Plates must be installed so that the arrows point in the same direction as the rotational arrows on the pump body. Port plates with ratio valves may not be installed in pump bodies prior to SV series 74, and VPV series B01. VPV series B01 requires the use of port plates with ratio valves for 45cc and larger pumps.
Pump will not prime	1) Shaft rotation in the wrong direction.	1) When installing a pump, always jog the electric motor to check for proper shaft rotation. Rotation should only be clockwise (right hand) for VPV pumps.
	2) Air leak in the suction line.	2) Make sure all fittings are tight.
	3) Pump is air bound.	3) Use an air bleed valve to void the pump and suction line of air.
	4) Fluid level in the reservoir is too low.	4) Fill the reservoir so that the fluid level is well above the end of the suction line.
	5) Stroke limiter is turned in too far.	5) Flow should not be reduced more than 50% of maximum. Turn CW to restrict flow, (see page 83).
	6) Suction port dust plug left in place.	6) Remove plug.
Pump is unstable	1) Contamination in the compensator.	1) Thoroughly clean the control orifices and check filtration.
	2) Pressure ring is not moving properly.	2) Control piston should be checked for freedom of movement.
Pump is too hot	1) Case drain line is installed too close to the pump inlet line.	1) The case drain and pump inlet should be separated by a baffle in the reservoir.
	2) Reservoir is undersized. Rule of thumb is a minimum or 2 to 3 times pump output flow.	2) Add a cooler.

Adapter Kits for VPV Combinations Using "P1" Pumps

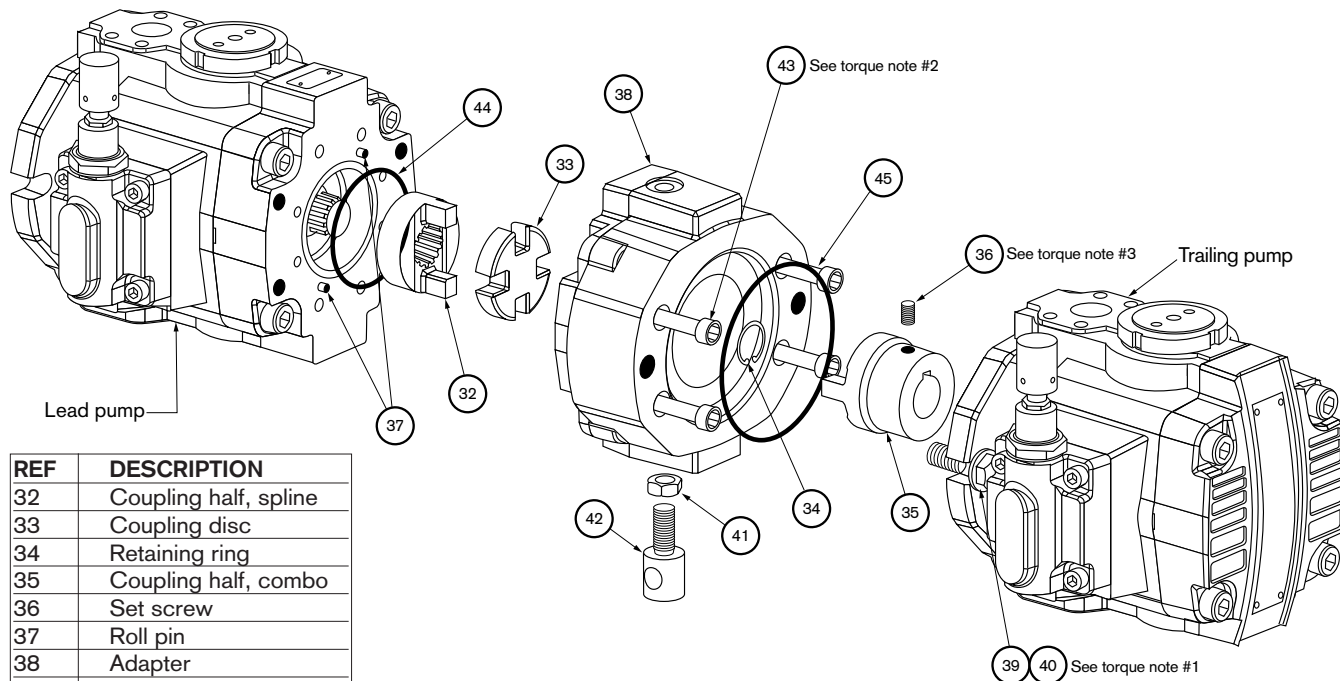

REF	DESCRIPTION
32	Coupling half, spline
33	Coupling disc
34	Retaining ring
35	Coupling half, combo
36	Set screw
37	Roll pin
38	Adapter
39	Washer
40	Hex head cap screw
41	Jam nut
42	Support
43	Soc. head cap screw
44	O-ring, ASA-043
45	O-ring

ADAPTER KITS	
LIST NUMBER	DESCRIPTION
9 511 230 518	VPV 16 to VPV 16 SAE
9 511 230 520	VPV 16 to VPV 16 Metric
9 511 230 521	VPV 16 to SAE "F" Gear
9 511 230 522	VPV 25/32 to VPV 25/32 Metric
9 511 230 523	VPV 25/32 to VPV 25/32 SAE
9 511 230 524	VPV 25/32 to VPV 16 Metric
9 511 230 525	VPV 25/32 to VPV 16 SAE
9 511 230 526	VPV Metric/SAE 25/32 to SAE "F" Gear
9 511 230 527	VPV 45/63/80 to VPV 45/63/80 Metric
9 511 230 528	VPV 45/63/80 to VPV 45/63/80 SAE
9 511 230 529	VPV 45/63/80 to VPV 25/32 Metric
9 511 230 530	VPV 45/63/80 to VPV 25/32 SAE
9 511 230 531	VPV 45/63/80 to VPV 16 Metric
9 511 230 532	VPV 45/63/80 to VPV 16 SAE
9 511 230 533	VPV Metric/SAE 45/63/80 to SAE "F" Gear
9 511 230 534	VPV Metric/SAE 45/63/80 to SAE "G" Gear
9 511 230 535	VPV Metric 100/130/164 to VPV 100/130/164
9 511 230 536	VPV SAE 100/130/164 to VPV 100/130/164
9 511 230 537	VPV Metric 100/130/164 to VPV 45/63/80
9 511 230 538	VPV SAE 100/130/164 to VPV 45/63/80
9 511 230 539	VPV Metric 100/130/164 to VPV 25/32
9 511 230 540	VPV SAE 100/130/164 to VPV 25/32
9 511 230 541	VPV Metric 100/130/164 to VPV 16
9 511 230 542	VPV SAE 100/130/164 to VPV 16
9 511 230 543	VPV Metric/SAE 100/130/164 to SAE "F" Gear
9 511 230 554	VPV Metric/SAE 32/25 to SAE "G" Gear
9 511 230 594	VPV Metric/SAE 100/130/164 to SAE "G" Gear
9 511 230 590	VPV Metric/SAE 100/130/164 to SAE "B" Spline

Torque Note #1	
Torque to 2000 lb/in (Torque to 225 Nm)	"VPV 100/130/164"
Torque to 1800 lb/in (Torque to 204 Nm)	"VPV 45/63/80"
Torque to 1050 lb/in (Torque to 119 Nm)	"VPV 25/32"
Torque to 780 lb/in (Torque to 88 Nm)	"VPV 16" & Type 'G' gear pump
Torque to 550 lb/in (Torque to 62 Nm)	Type 'F' gear pump
Torque Note #2	
Torque to 2300 lb/in (Torque to 260 Nm)	"VPV 100/130/164"
Torque to 850 lb/in (Torque to 96 Nm)	"VPV 45/63/80"
Torque to 550 lb/in (Torque to 62 Nm)	"VPV 25/32" & Type 'G' gear pump
Torque to 400 lb/in (Torque to 46 Nm)	"VPV 16" & Type 'F' gear pump
Torque Note #3	
Torque to 800 lb/in (Torque to 90 Nm)	"VPV 100/130/164"
Torque to 330 lb/in (Torque to 37 Nm)	"VPV 45/63/80"
Torque to 280 lb/in (Torque to 31.5 Nm)	"VPV 25/32" & Type 'G' gear pump
Torque to 200 lb/in (Torque to 22.5 Nm)	Type 'F' gear pump

Through Drive Horsepower Limitations

The VPV pumps can be cooupled with other VPV pumps, Bosch gear pumps or other pumps with standard SAE or metric mounting patterns. (VPV pumps can be coupled without losing use of stroke limiter.) VPV combination pumps are rated to carry the load of an additional pump(s) equal to the maximum load the lead VPV pump can generate (see chart).

Pump	Flow @ 1750 RPM (gpm)	Maximum Pressure (psig)	Pump #1 Input Horsepower	Maximum Input Power for other pumps
VPV 16	8.03	3000	17.6	17.6
VPV 25	12.6	3000	25.3	25.3
VPV 32	15.4	3000	30.7	30.7
VPV 45	21.8	3000	43.3	43.3
VPV 63	29.6	3000	58.5	58.5
VPV 80	37.2	3000	74.6	74.6
VPV 100	46.2	3000	88.8	88.8
VPV 130	60.0	3000	117.6	117.6
VPV 164	75.8	3000	156.5	156.5

EXAMPLES:

VPV 100 @ 3045 psig + VPV 63 @ 3045 psig + VPV 25 @ 3045 psig
 88.8 hp ≥ 58.5 hp + 23.3 hp

VPV 116 @ 3045 psig + VPV 16 @ 1500 psig + VPV 16 @ 1500 psig
 17.6 hp ≥ 8.7 hp + 8.7 hp

VPV Stroke Limiter Adjustment

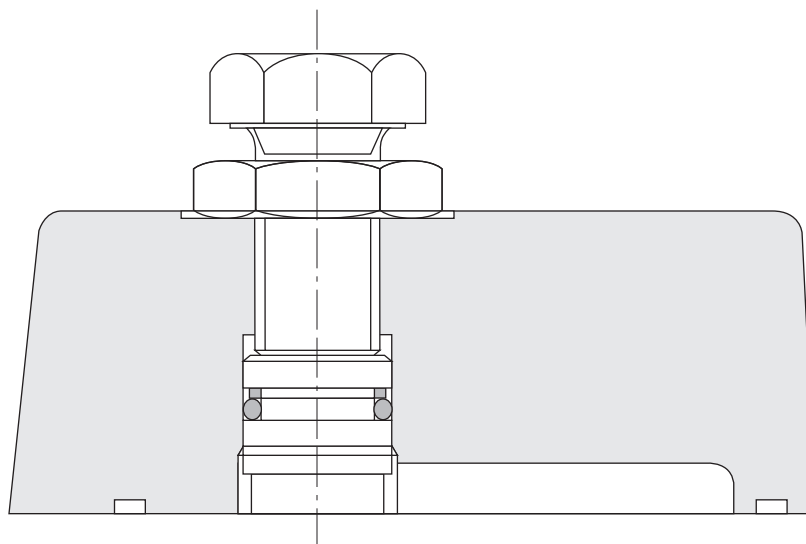

Pump Model	Nominal Stroke	Decrease in Flow Per Turn	Minimum Flow Attainable
VPV 16	1.9 mm (0.075")	53%	<0%
VPV 25	2.0 mm (0.080")	50%	0%
VPV 32	2.5 mm (0.099")	40%	20%
VPV 45	1.9 mm (0.077")	80%	<0%
VPV 63	2.7 mm (0.106")	56%	8%
VPV 80	3.4 mm (0.132")	44%	26%
VPV 100	3.0 mm (0.117")	50%	17%
VPV 130	3.8 mm (0.150")	40%	34%
VPV 164	4.7 mm (0.186")	32%	47%

- During initial start-up, volume should be at least 30% of maximum flow.
- Only make adjustments to volume control with pump running at full flow and low pressure while observing output flow.

2000 PSI Repair Parts – VPV 16/25/32

REPAIR KITS		
SIZE	SAE	METRIC
16	9 511 230 504	9 511 230 505
25	9 511 230 506	9 511 230 507
32	9 511 230 506	9 511 230 507

SEAL KITS		
SIZE	SAE	METRIC
16	9 511 230 500	9 511 230 500
25	9 511 230 501	9 511 230 501
32	9 511 230 501	9 511 230 501

Repair kits consists of:

REF	DESCRIPTION	QTY
1	Key	1
2	Roll pin	4
3	Vane set	1
4	Spacer ring	1
5	Pressure ring	1
6	Port plate, body	1
7	Port plate, cover	1
8	Thrust screw	1
9	Lock nut	1
10	Shaft	1
11	Retaining ring (VPV 16)	1
12	Bearing	2

Repair kits consists of:

REF	DESC., VPV16/(VPV25/32)	QTY
13	O-ring, ASA-111 / (ASA-111)	1
14	O-ring, ASA-110 / (ASA-110)	1
15	O-ring, ASA-127 / (ASA-136)	2
16	O-ring, ASA-128 / (ASA-128)	1
17	O-ring, ASA-026 / (ASA-028)	2
18	O-ring, ASA-151 / (ASA-152)	2
19	O-ring, ASA-031 / (ASA-031)	1
20	O-ring, ASA-156 / (ASA-160)	1
21	Back up ring	2
22	Shaft seal	1
23	O-ring, ASA-011	1
24	Back up ring	1
25	Control piston	1
26	Bias piston	1

(All O-rings durometer rating = 75)

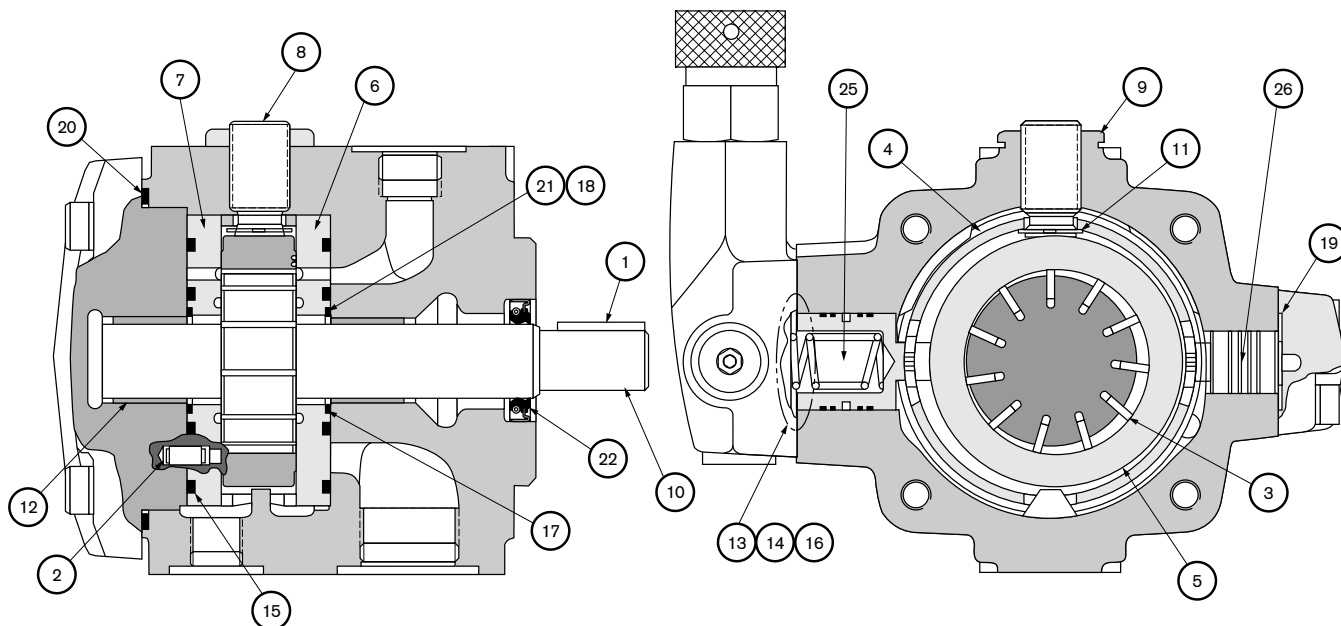
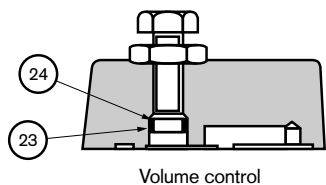

2000 PSI Repair Parts – VPV 16/25/32

INSTALLATION NOTES

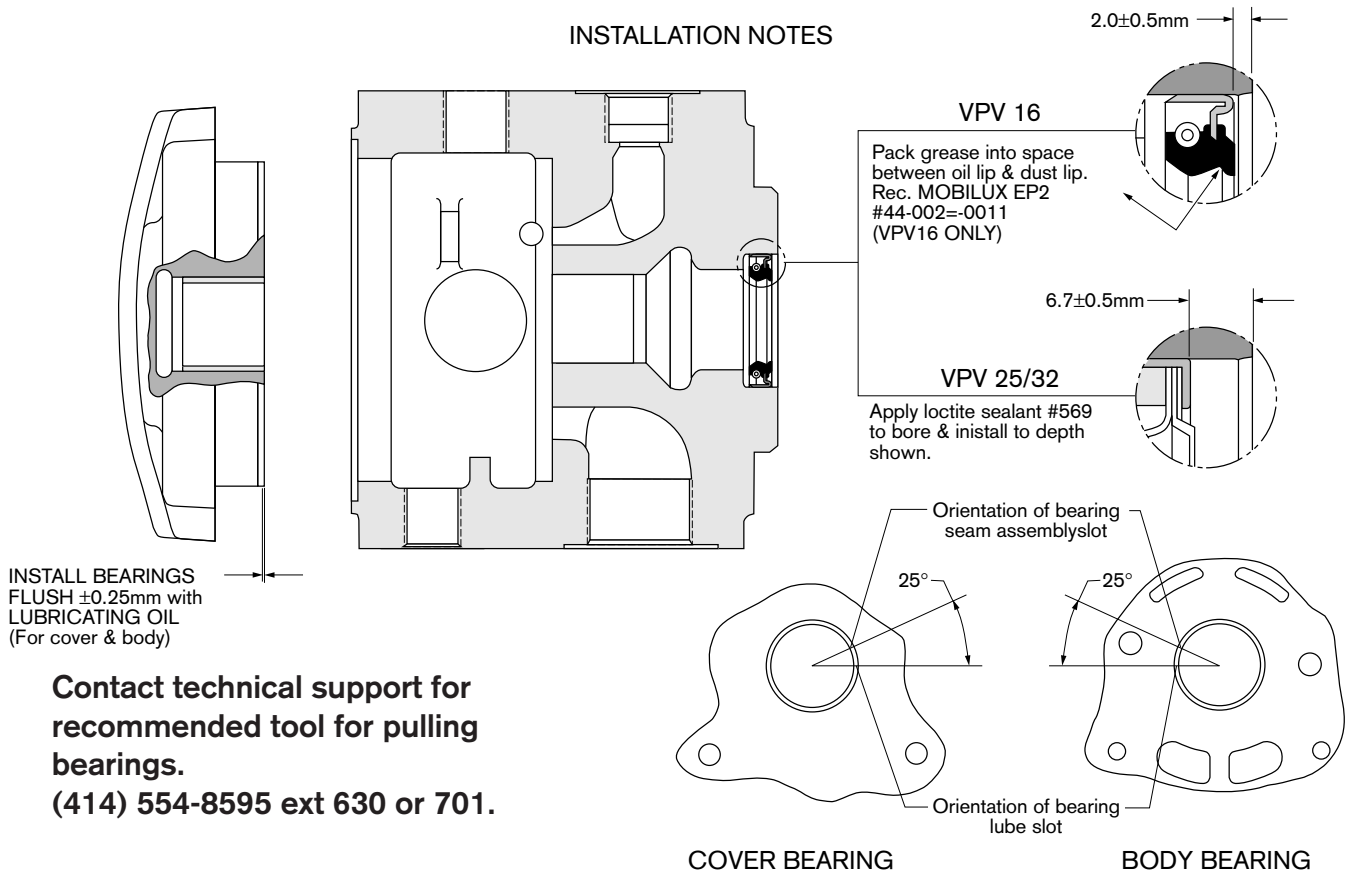

Contact technical support for recommended tool for pulling bearings.
 (414) 554-8595 ext 630 or 701.

TORQUE RATINGS

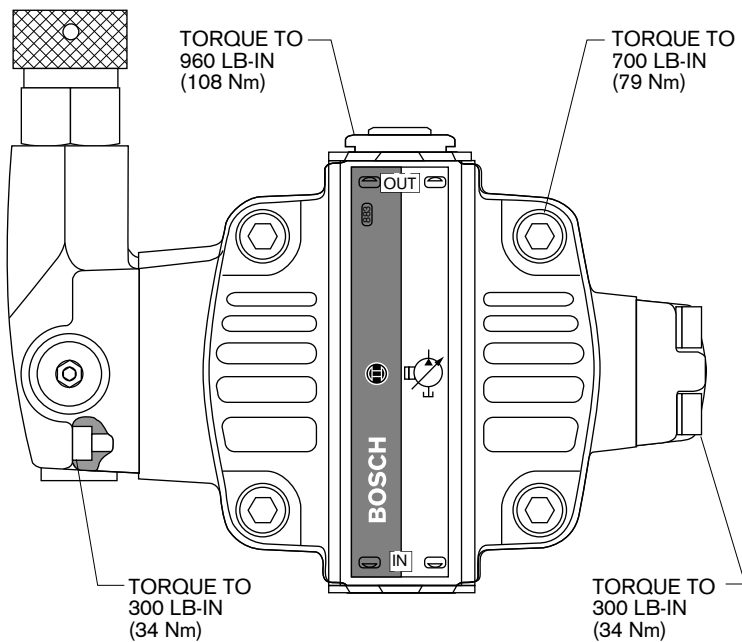

VOLUME CONTROL ASSEMBLY	
9 537 232 000	

Assembly consists of:

REF	DESCRIPTION	QTY
1	O-ring (-011 / 75)	1
2	Back up ring	1
3	Piston	1
4	Body	1
5	Adjusting screw	1
6	Jam nut	1

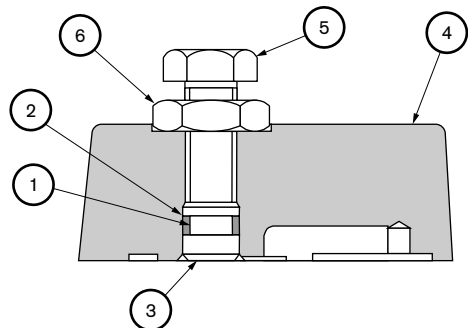

2000 PSI Repair Parts – VPV 16/25/32

SINGLE STAGE COMPENSATOR

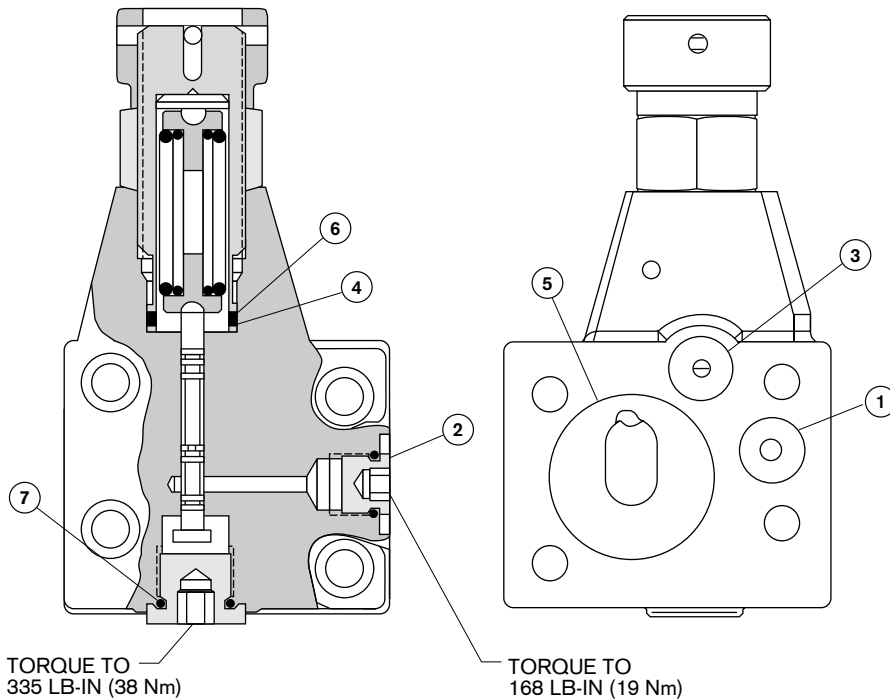

COMPLETE ASSEMBLY FOR SINGLE STAGE COMPENSATOR	
SAE	9 511 230 513
METRIC	9 511 230 512

REPAIR KIT FOR SINGLE STAGE COMPENSATOR	
SAE	9 511 230 624
METRIC	9 511 230 510

Repair kit consists of:

REF	DESCRIPTION	QTY
1	O-ring (-011 / 75)	1
2	Plug w/ O-ring	1
3	O-ring (-110 / 75)	1
4	O-ring (-018 / 75)	1
5	O-ring (-128 / 75) *	1
6	Back up ring	1
7	O-ring	1

*=If O-ring is teardrop shape use 9 511 230 511 (SAE)

BOLT KIT FOR MOUNTING SINGLE STAGE TO VPV 16/25/32 (M8 X 1.25 X 25)	
9 539 232 012	

TWO-STAGE COMPENSATOR

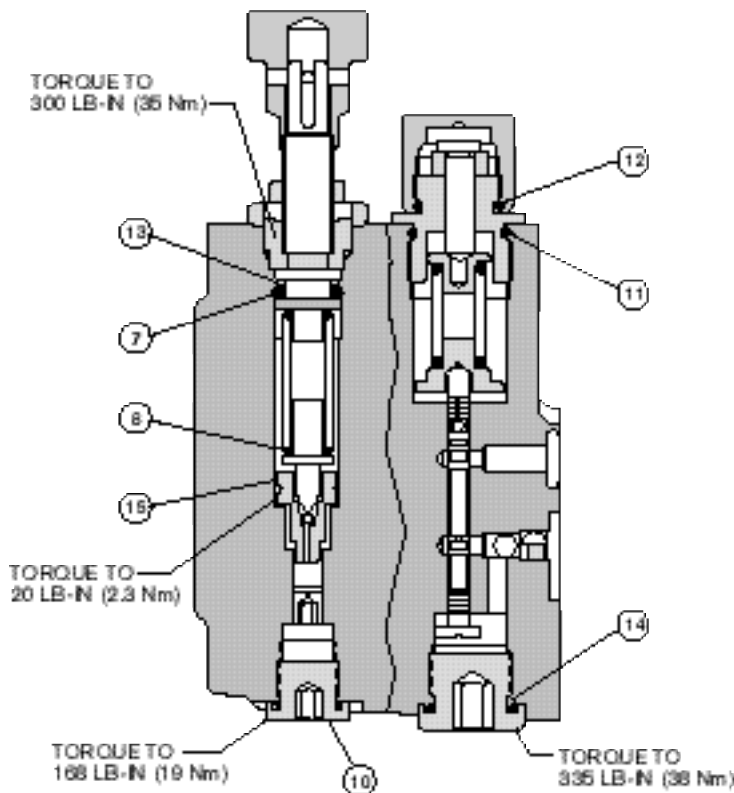

COMPLETE ASSEMBLY FOR TWO-STAGE COMPENSATOR	
SAE	9 511 230 514
METRIC	9 511 230 515

COMPLETE ASSEMBLY FOR LOAD SENSE	
SAE	9 511 230 600
METRIC	Consult factory

REPAIR KIT FOR TWO-STAGE COMPENSATOR	
SAE	9 511 230 624
METRIC	9 511 230 516

Repair kit consists of:

REF	DESC. (ASA#/durometer)	QTY
1*	O-ring (-111 / 75)	2
2*	Plug w/ O-ring	1
3*	O-ring (-110 / 75)	1
5*	O-ring (-128 / 75)	1
7	O-ring (-111 / 75)	1
8	Poppet second stage	1
10	Plug w/ O-ring	1
11	O-ring (-910 / 75)	1
12	O-ring (-908 / 75)	1
13	Back up ring	1
14	O-ring	1
15	Poppet seat w/ O-ring	1

*=See above view for location of Ref. #1, 2, 3,5

BOLT KIT FOR MOUNTING TWO STAGE & SOLENOID COMPENSATORS TO VPV 16/25/32 (M8 X 1.25 X 45)	
9 539 232 013	

2000 PSI Repair Parts – VPV 45 – 164

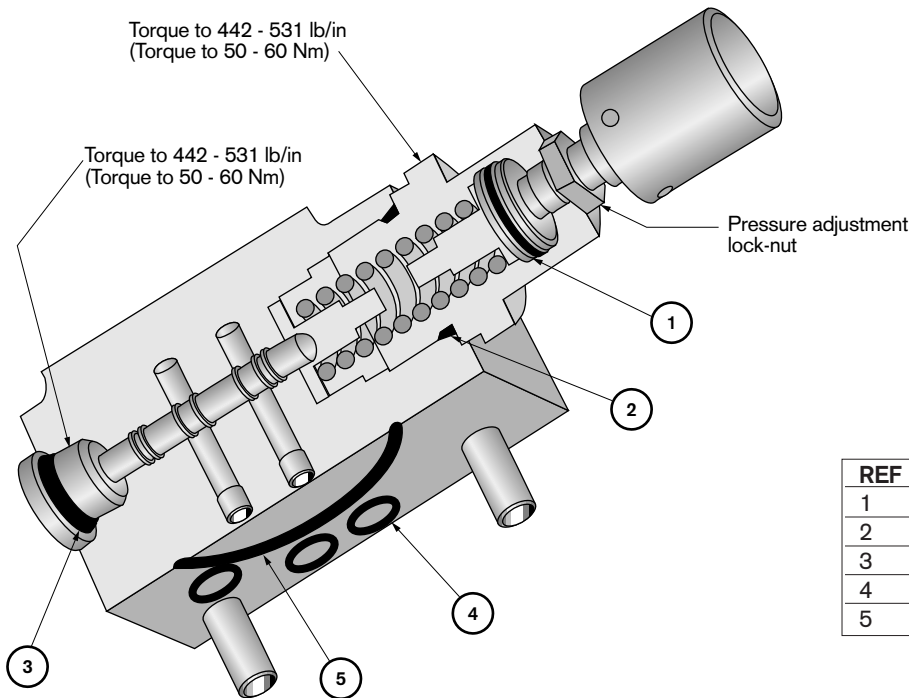

COMPLETE ASSEMBLY FOR SINGLE STAGE COMPENSATOR
9 511 230 548
SAE and METRIC

SEAL KIT FOR SINGLE STAGE COMPENSATOR
9 511 230 545
SAE and METRIC

Viton seal kits consist of:

REF	DESCRIPTION	QTY
1	O-ring 19mm i.d. X 2.5mm c.s.	1
2	O-ring ASA-916	1
3	O-ring 15.3mm i.d. X 2.4mm c.s.	1
4	O-ring ASA-111	3
5	O-ring ASA-143	1

TWO-STAGE COMPENSATOR

Note:
 Qty of 3, M6 S.H.C.S. not shown.
 Mounts 2nd stage to 1st stage compensator
 Torque to 133 - 177 lb/in
 (Torque to 15 - 20 Nm)

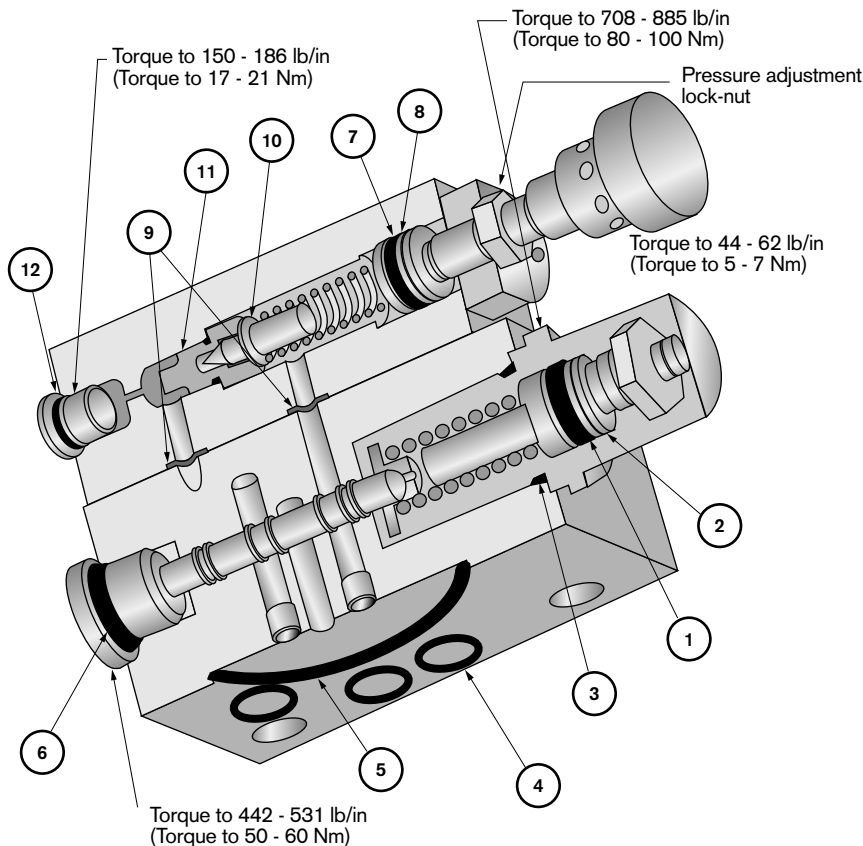

COMPLETE ASSEMBLY FOR TWO-STAGE COMPENSATOR	
SAE	9 511 230 550
METRIC	9 511 230 551

COMPLETE ASSEMBLY FOR LOAD SENSE	
SAE	9 511 230 589
METRIC	9 511 230 588

REPAIR KIT FOR TWO-STAGE COMPENSATOR	
SAE	9 511 230 546
METRIC	9 511 230 552

Repair kit consists of:

REF	DESCRIPTION	QTY
1	O-ring ASA-113	1
2	Back up ring	1
3	O-ring	1
4	O-ring ASA-111	3
5	O-ring ASA-143	1
6	O-ring 15.3, i.d. x 2.4mm c.s.	1
7	O-ring ASA-111	1
8	Back up ring	1
9	O-ring ASA-011	2
10	Poppet	1
11	Poppet seat w/ O-ring	1
12	Plug w/ O-ring	1

BOLT KIT FOR MOUNTING TWO STAGE & SOLENOID COMPENSATORS TO VPV 45/164 (M10 X 1.5 X 40)
9 539 232 014

2000 PSI Repair Parts – VPV 45 – 164

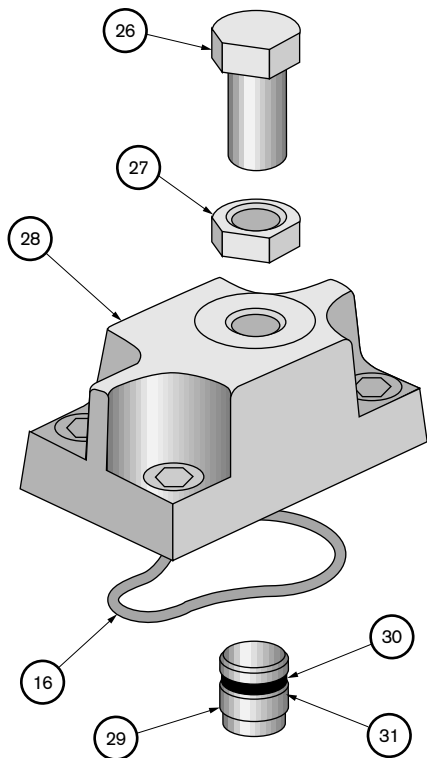

VOLUME CONTROL ASSEMBLY
 9 537 232 002

Repair kits consists of:

REF	DESCRIPTION	QTY
16	O-ring, ASA-146	1
26	Adjusting screw	1
27	Jam nut	1
28	Body	1
29	Piston	1
30	Back up ring	1
31	O-ring, ASA-113	1

REPAIR KITS				
SIZE	SAE	METRIC	SAE "P1"	METRIC "P1"
45	9 511 230 559	9 511 230 564	9 511 230 576	9 511 230 579
63	9 511 230 562	9 511 230 566	9 511 230 577	9 511 230 580
80	9 511 230 563	9 511 230 567	9 511 230 578	9 511 230 581
100	9 511 230 568	9 511 230 573	9 511 230 582	9 511 230 585
130	9 511 230 571	9 511 230 574	9 511 230 583	9 511 230 586
164	9 511 230 572	9 511 230 575	9 511 230 584	9 511 230 587

SEAL KITS	
SIZE	PART NUMBER
45-80	9 511 230 544
100-164	9 511 230 547

Repair kits consists of:

REF	DESCRIPTION	QTY
1	Key	1
2	Rotor shaft	1
3	Vane kit	1
4	Port plate, cover side	1
5	Roll pin	4
6	Thrust block kit	1
7	Bearing	2
8	Spacer ring	1
9	Pressure ring	1
10	Port plate, body side	1

Viton seal kits consist of:

REF	DESC., VPV45/80/(VPV100/164)	QTY
13	O-ring, ASA-031 / (ASA-035)	2
14	O-ring, ASA-162 / (ASA-265)	1
15	O-ring, ASA-130 / (ASA-229)	1
16	O-ring, ASA-146 / (ASA-146)	1
17	Shaft seal	1
18	O-ring, ASA-229 / (ASA-237)	1
19	O-ring, ASA-110 / (ASA-110)	1
20	O-ring, ASA-111 / (ASA-111)	3
21	O-ring, ASA-143 / (ASA-143)	1
22	O-ring, ASA-157 / (ASA-160)	2
23	Back up ring	2
24	O-ring, ASA-139 / (ASA-152)	2
24	O-ring, ASA-043 / (ASA-043)	1

(All o-rings durmoeter rating = 75)

2000 PSI Cutaway – VPV 45 – 164

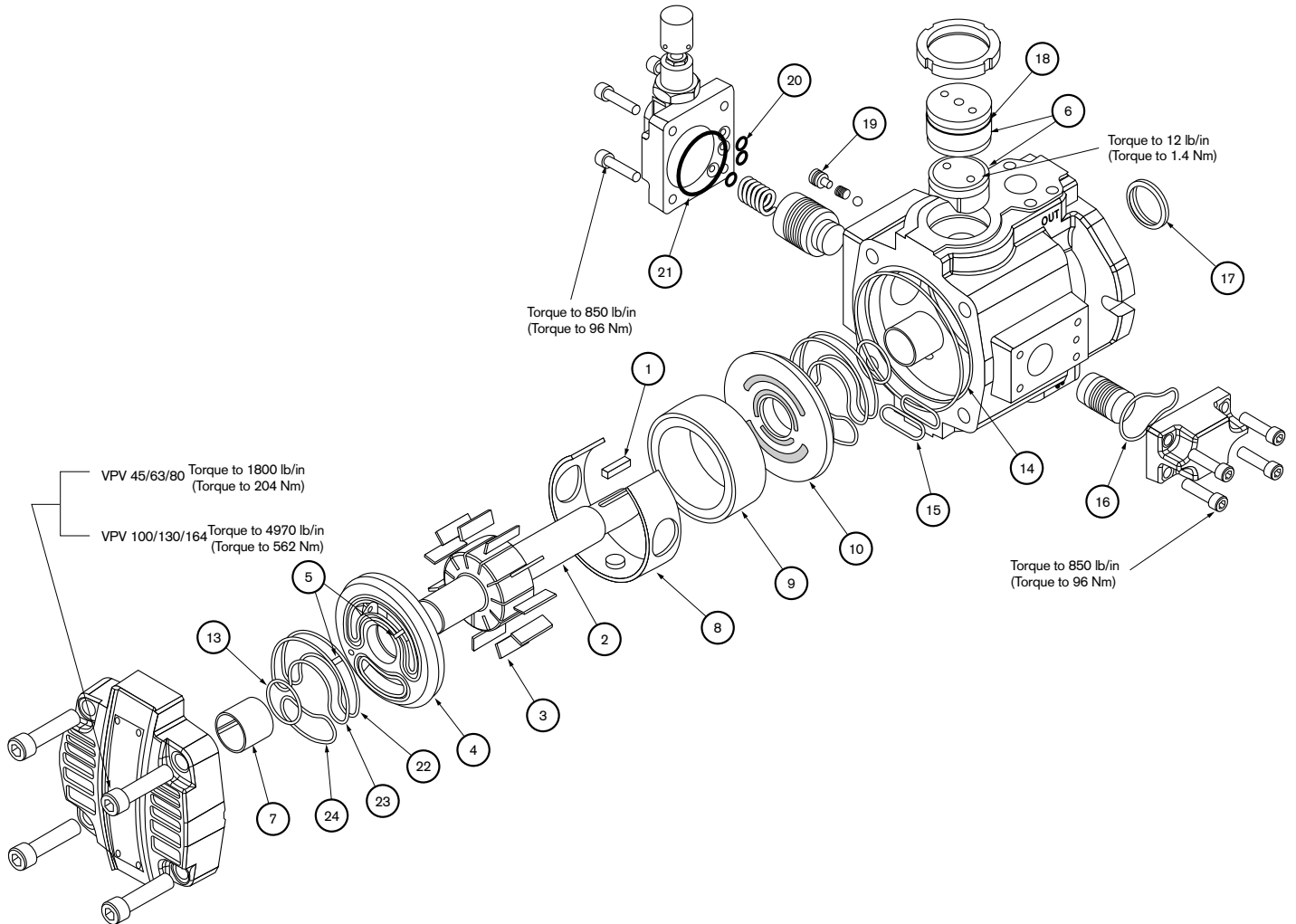
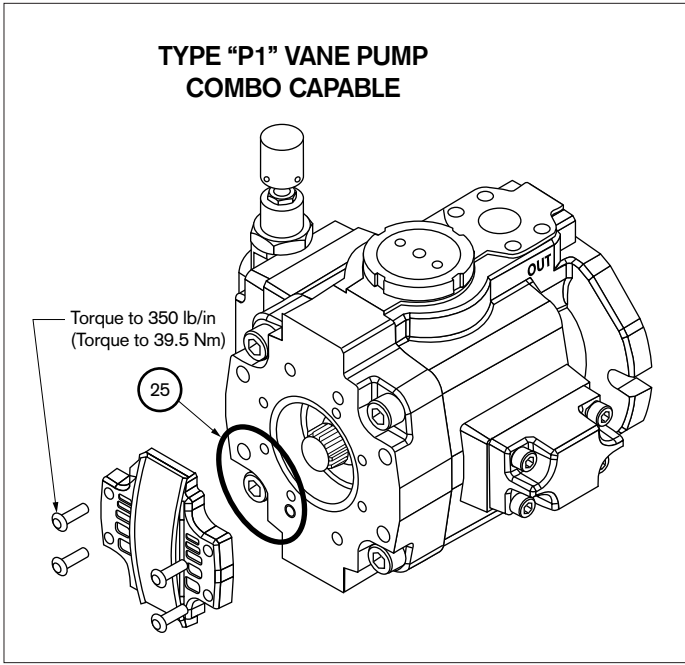

3000 PSI Repair Parts – VPV 16/25/32

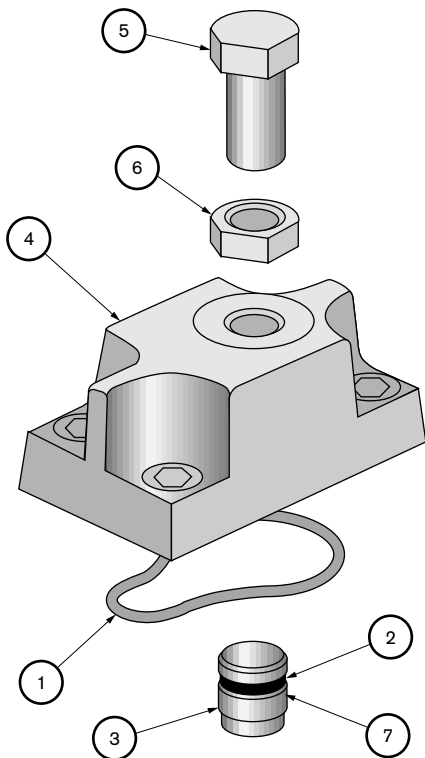

VOLUME CONTROL ASSEMBLY
 9 537 232 004

Repair kits consists of:

REF	DESCRIPTION	QTY
1	O-ring, (-011/75)	1
2	Back up ring	1
3	Piston	1
4	Body	1
5	Adjusting screw	1
6	Jam nut	1
7	O-Ring ASA-113	1

REPAIR KITS				
SIZE	SAE	METRIC	SAE "P1"	METRIC "P1"
16	9 511 230 606	9 511 230 607	9 511 230 608	9 511 230 609
25	9 511 230 598	9 511 230 599	9 511 230 623	9 511 230 622
32	9 511 230 598	9 511 230 599	9 511 230 623	9 511 230 622

SEAL KITS		
SIZE	SAE	METRIC
16	9 511 230 605	9 511 230 605
25/32	9 511 230 558	9 511 230 597

Repair kits consists of:

DESCRIPTION	QTY
Key	1
Rotor shaft	1
Vane kit	1
Port plate, cover side	1
Roll pin	4
Thrust block kit	1
Bearing	2
Spacer ring	1
Pressure ring	1
Port plate, body side	1

Viton seal kits consist of:

Desc., VPV16/(VPV25/32)	QTY
O-ring, ASA-111 / (ASA-111)	1
O-ring, ASA-110 / (ASA-110)	1
O-ring, ASA-127 / (ASA-136)	2
O-ring, ASA-128 / (ASA-128)	1
O-ring, ASA-026 / (ASA-028)	2
O-ring, ASA-151 / (ASA-152)	2
O-ring, ASA-031 / (ASA-031)	1
O-ring, ASA-156 / (ASA-160)	1
Back up ring	2
Shaft seal	1
O-ring, ASA-011	1
Back up ring	1
Control piston	1
Bias piston	1

(All o-rings durmoeter rating = 75)

3000 PSI Repair Parts – VPV 16/25/32

ATTENTION: These compensators are rated for 210 bar (3000 psi) operation. Install only on pumps rated at 210 bar (3000 psi). Activating shock clipper is highly recommended on all applications greater than 140 bar (2000 psi). Install unrestricted line back to tank.

SINGLE STAGE COMPENSATOR

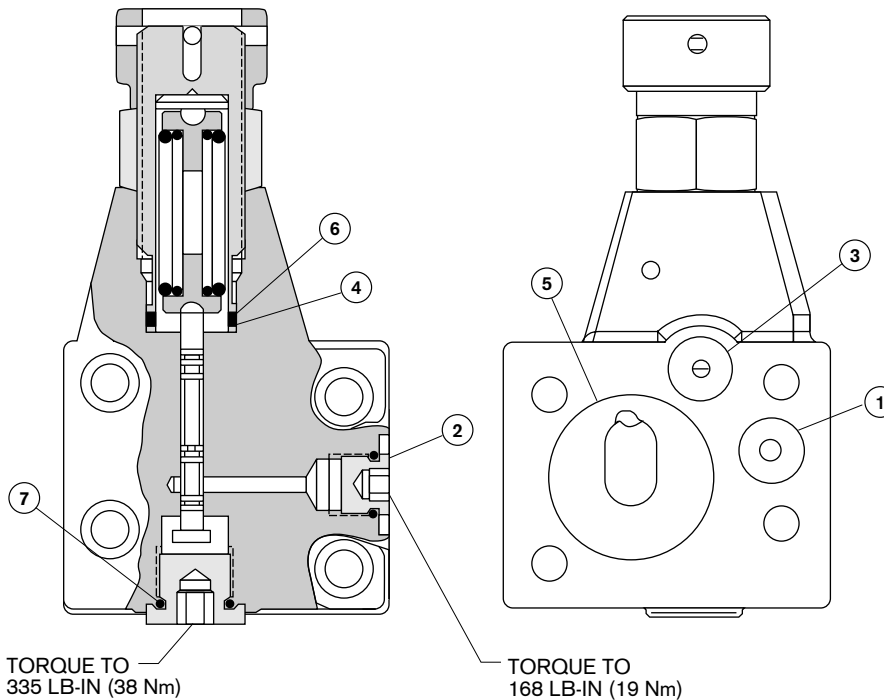

COMPLETE ASSEMBLY FOR SINGLE STAGE COMPENSATOR	
SAE	9 511 230 595
METRIC	9 511 230 596

REPAIR KIT FOR SINGLE STAGE COMPENSATOR	
SAE	9 511 230 625
METRIC	9 511 230 626

Repair kit consists of:

REF	DESCRIPTION	QTY
1	O-ring (-011 / 75)	1
2	Plug w/ O-ring	1
3	O-ring (-110 / 75)	1
4	O-ring (-018 / 75)	1
5	O-ring (-128 / 75)	1
6	Back up ring	1
7	O-ring	1

BOLT KIT FOR MOUNTING SINGLE STAGE TO VPV 16/25/32 (M8 X 1.25 X 25)	
9 539 232 012	

TWO-STAGE COMPENSATOR

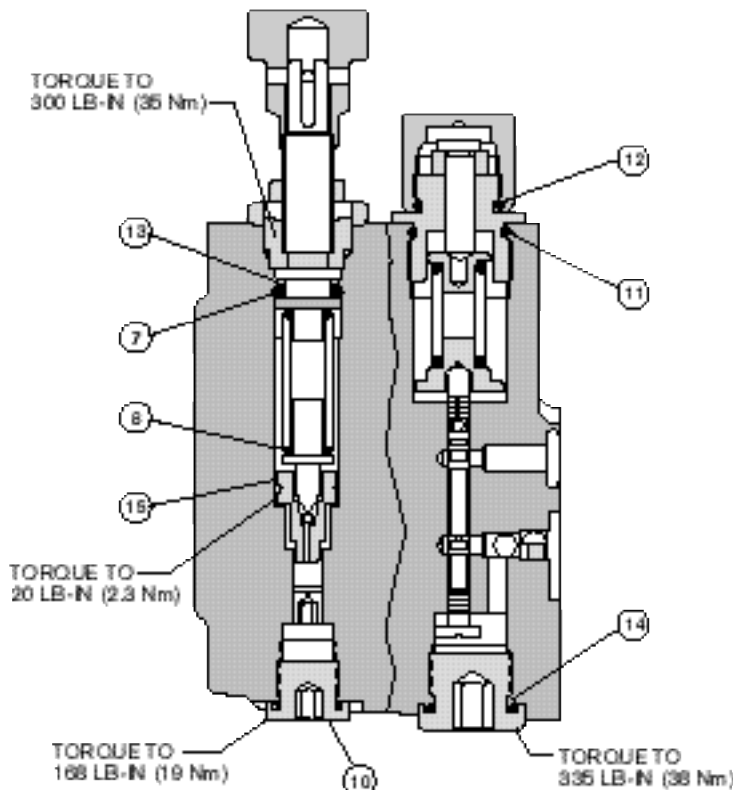

COMPLETE ASSEMBLY FOR TWO-STAGE COMPENSATOR	
SAE	9 511 230 601
METRIC	9 511 230 602

COMPLETE ASSEMBLY FOR LOAD SENSE	
SAE	9 511 230 603
METRIC	9 511 230 604

REPAIR KIT FOR TWO-STAGE COMPENSATOR	
SAE	9 511 230 627
METRIC	9 511 230 628

Repair kit consists of:

REF	DESC. (ASA#/durometer)	QTY
1*	O-ring (-111 / 75)	2
2*	Plug w/ O-ring	1
3*	O-ring (-110 / 75)	1
5*	O-ring (-128 / 75)	1
7	O-ring (-111 / 75)	1
8	Poppet second stage	1
10	Plug w/ O-ring	1
11	O-ring (-910 / 75)	1
12	O-ring (-908 / 75)	1
13	Back up ring	1
14	O-ring	1
15	Poppet seat w/ O-ring	1

*=See above view for location of Ref. #1, 2, 3,5

BOLT KIT FOR MOUNTING TWO STAGE & SOLENOID COMPENSATORS TO VPV 16/25/32 (M8 X 1.25 X 45)	
9 539 232 013	

3000 PSI Repair Parts – VPV 16/25/32

INSTALLATION NOTES

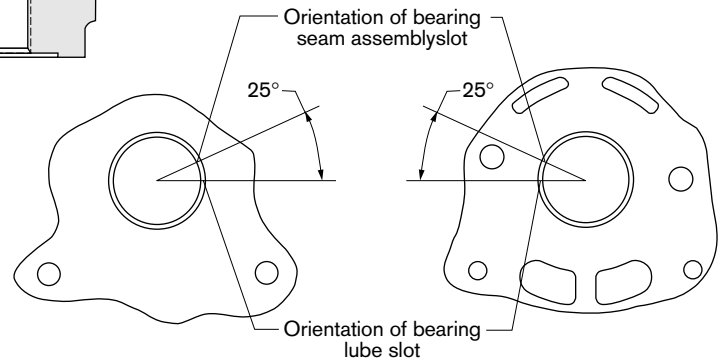
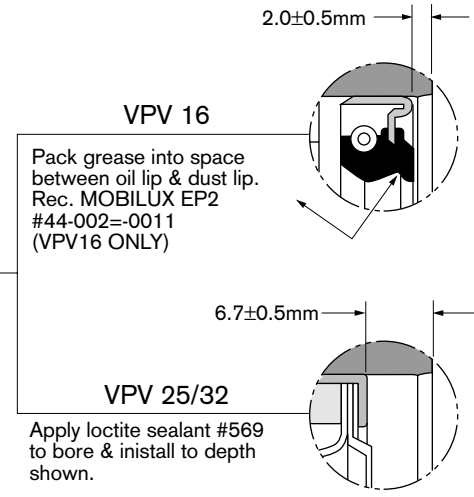
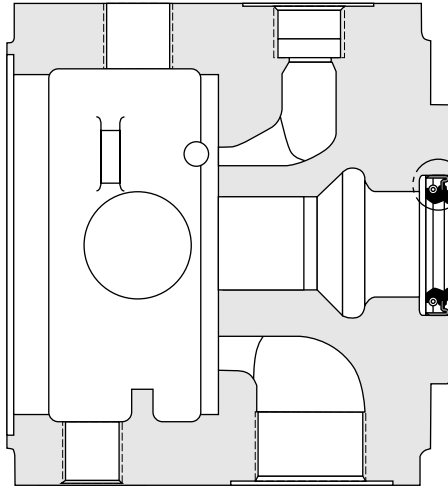
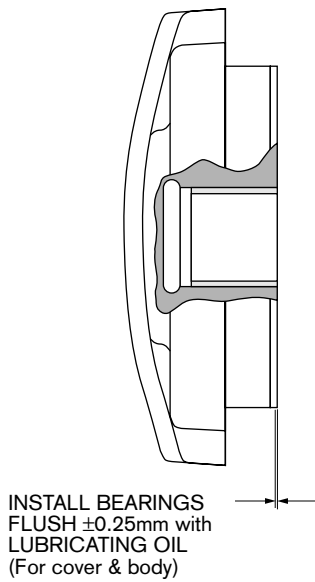

COVER BEARING

BODY BEARING

Contact technical support for
 recommended tool for pulling
 bearings.
 (414) 554-8595 ext 630 or 701.

TORQUE RATINGS

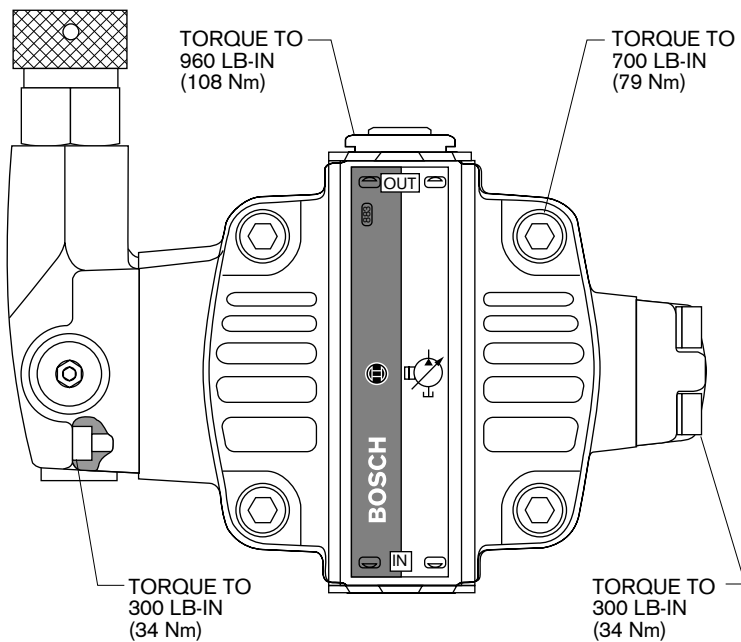

VOLUME CONTROL ASSEMBLY
 9 537 232 000

Assembly consists of:

REF	DESCRIPTION	QTY
1	O-ring (-011 / 75)	1
2	Back up ring	1
3	Piston	1
4	Body	1
5	Adjusting screw	1
6	Jam nut	1

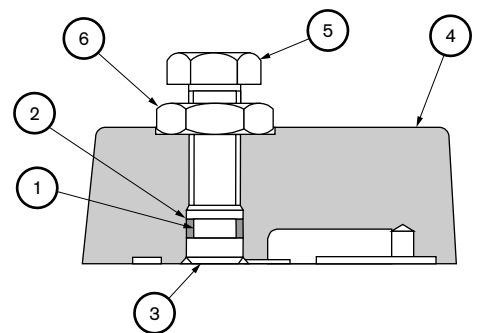

3000 PSI Repair Parts – VPV 45 – 164

ATTENTION: These compensators are rated for 210 bar (3000 psi) operation. Install only on pumps rated at 210 bar (3000 psi).

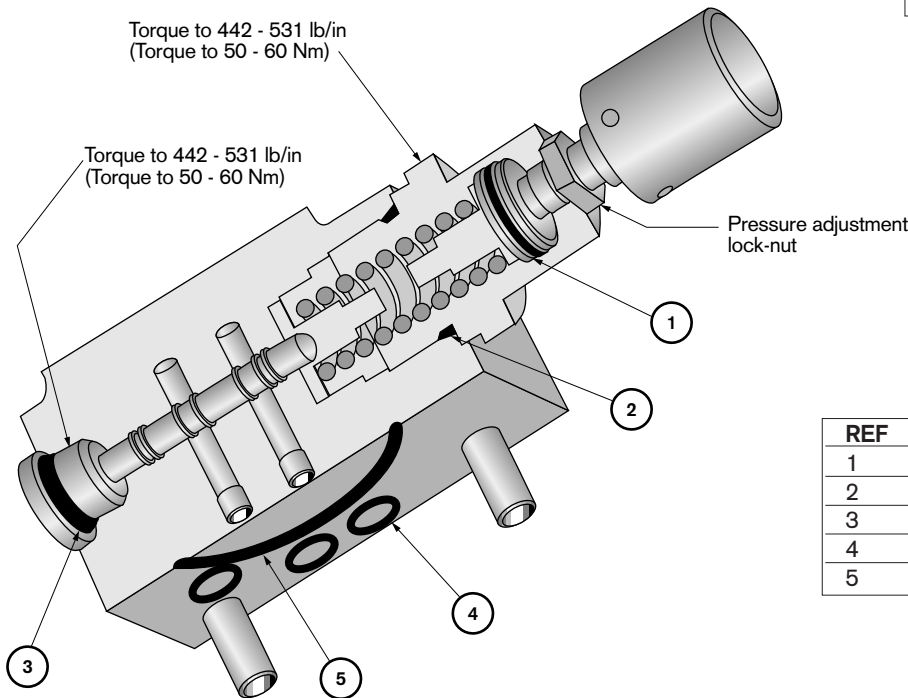

COMPLETE ASSEMBLY FOR SINGLE STAGE COMPENSATOR

Consult factory.

SEAL KIT FOR SINGLE STAGE COMPENSATOR

Consult factory.

Viton seal kits consist of:

REF	DESCRIPTION	QTY
1	O-ring 19mm i.d. X 2.5mm c.s.	1
2	O-ring ASA-916	1
3	O-ring 15.3mm i.d. X 2.4mm c.s.	1
4	O-ring ASA-111	3
5	O-ring ASA-143	1

TWO-STAGE COMPENSATOR

Note:
 Qty of 3, M6 S.H.C.S. not shown.
 Mounts 2nd stage to 1st stage compensator
 Torque to 133 - 177 lb/in
 (Torque to 15 - 20 Nm.)

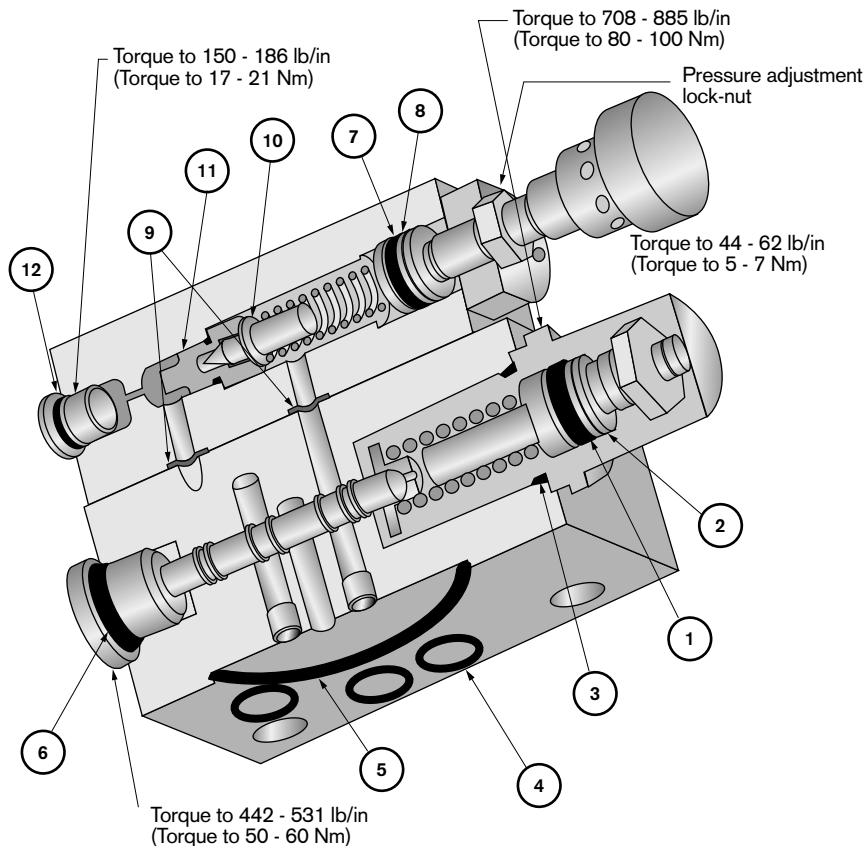

COMPLETE ASSEMBLY FOR TWO STAGE COMPENSATOR

SAE	9 511 230 610
METRIC	9 511 230 611

COMPLETE ASSEMBLY FOR LOAD SENSE

SAE	9 511 230 612
METRIC	9 511 230 613

REPAIR KIT FOR TWO-STAGE COMPENSATOR

SAE	9 511 230 660
METRIC	9 511 230 661

Repair kit consists of:

REF	DESCRIPTION	QTY
1	O-ring ASA-113	1
2	Back up ring	1
3	O-ring	1
4	O-ring ASA-111	3
5	O-ring ASA-143	1
6	O-ring 15.3, i.d. x 2.4mm c.s.	1
7	O-ring ASA-111	1
8	Back up ring	1
9	O-ring ASA-011	2
10	Poppet	1
11	Poppet seat w/ O-ring	1
12	Plug w/ O-ring	1

BOLT KIT FOR MOUNTING TWO STAGE & SOLENOID COMPENSATORS TO VPV 45/164 (M10 X 1.5 X 40)

9 539 232 014

3000 PSI Repair Parts – VPV 45 – 164

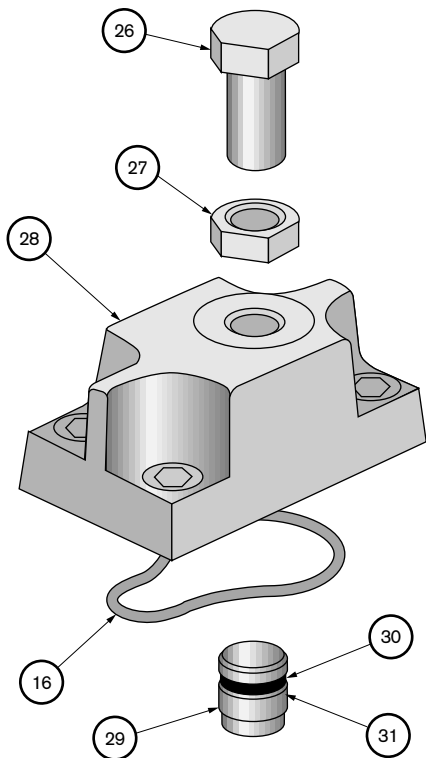

VOLUME CONTROL ASSEMBLY
 9 537 232 005

Repair kits consists of:

REF	DESCRIPTION	QTY
16	O-ring, ASA-146	1
26	Adjusting screw	1
27	Jam nut	1
28	Body	1
29	Piston	1
30	Back up ring	1
31	O-ring, ASA-113	1

REPAIR KITS				
SIZE	SAE	METRIC	SAE "P1"	METRIC "P1"
45	9 511 230 639	9 511 230 644	9 511 230 642	9 511 230 646
63	9 511 230 639	9 511 230 644	9 511 230 642	9 511 230 646
80	9 511 230 641	9 511 230 645	9 511 230 643	9 511 230 647
100	9 511 230 650	9 511 230 654	9 511 230 652	9 511 230 656
130	9 511 230 650	9 511 230 654	9 511 230 652	9 511 230 656
164	9 511 230 651	9 511 230 655	9 511 230 653	9 511 230 657

SEAL KITS		
SIZE	SAE	METRIC
45-80	9 511 230 658	9 511 230 658
100-164	9 511 230 659	9 511 230 659

Repair kits consists of:

REF	DESCRIPTION	QTY
1	Key	1
2	Rotor shaft	1
3	Vane kit	1
4	Port plate, cover side	1
5	Roll pin	4
6	Thrust block kit	1
7	Bearing	2
8	Spacer ring	1
9	Pressure ring	1
10	Port plate, body side	1

Viton seal kits consist of:

REF	DESC., VPV45/80/(VPV100/164)	QTY
13	O-ring, ASA-031 / (ASA-035)	2
14	O-ring, ASA-162 / (ASA-265)	1
15	O-ring, ASA-130 / (ASA-229)	1
16	O-ring, ASA-146 / (ASA-146)	1
17	Shaft seal	1
18	O-ring, ASA-229 / (ASA-237)	1
19	O-ring, ASA-110 / (ASA-110)	1
20	O-ring, ASA-111 / (ASA-111)	3
21	O-ring, ASA-143 / (ASA-143)	1
22	O-ring, ASA-157 / (ASA-160)	2
23	Back up ring	2
24	O-ring, ASA-139 / (ASA-152)	2
24	O-ring, ASA-043 / (ASA-043)	1

(All o-rings durmoeter rating = 75)

Vane Tip Orientation

Orient vanes as shown when servicing VPV Whisper™ Pumps.

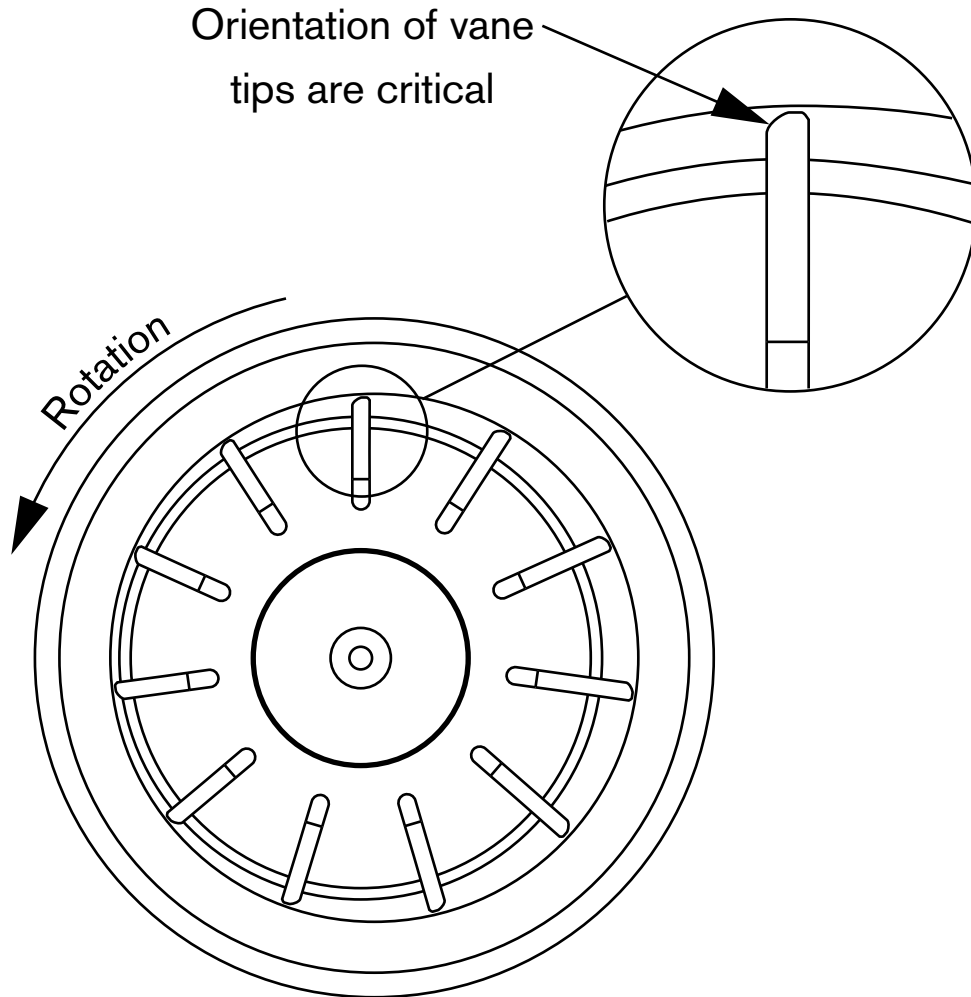

Looking into pump body
from cover side

VPV Tool Kit

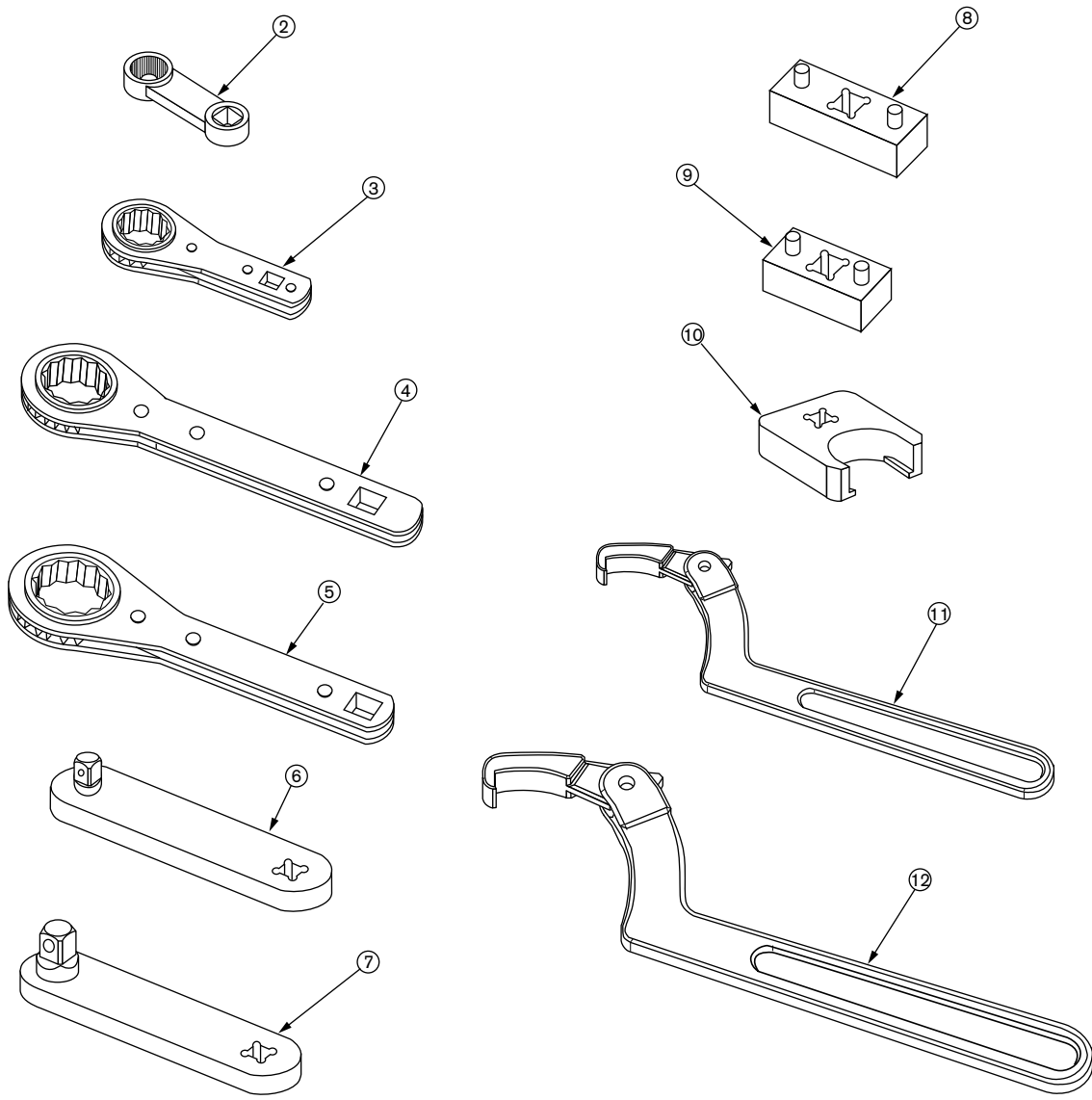

VPV tool kit consists of:

ITEM #	DESCRIPTION
1	Wrench adapter, 13mm
2	Wrench adapter, 17mm
3	Wrench adapter, 19mm, VPV25/32
4	Wrench adapter 24mm, VPV45/63/80
5	Wrench adapter, 30mm, VPV100/130/164
6	Extension bar, 3/8" socket
7	Extension bar, 1/2" socket
8	Spanner socket, VPV100/130/164
9	Spanner socket, VPV45/63/80
10	Crowfoot, VPV16/25/32, locknut
11	Spanner wrench, VPV45/63/80
12	Spanner wrench, VPV100/130/164

VPV tool kit
 9 511 230 557

Reaction Characteristics and Shock Clipper Function

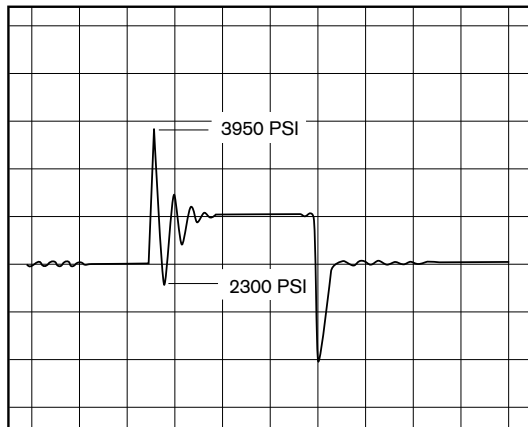
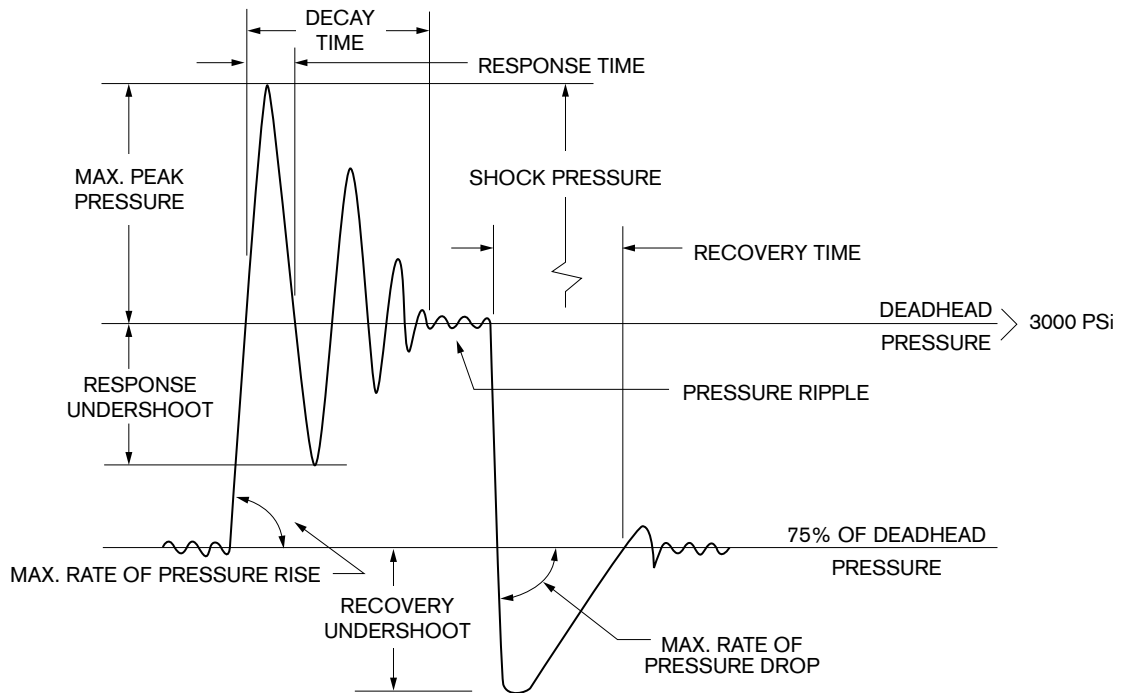

VPV 16, Single stage compensator, plot with shock clipper inactive. (Response overshoot of 950 PSI, response undershoot of 700 PSI)

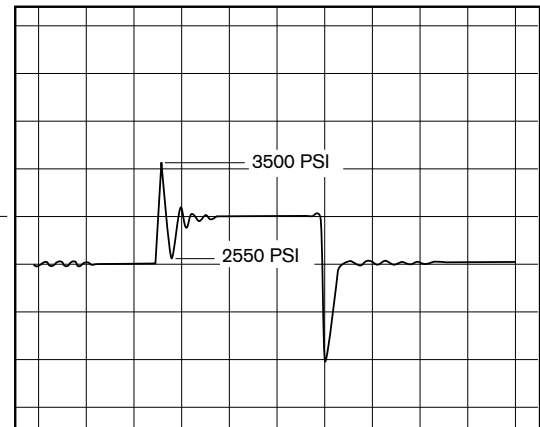

VPV 16, Single stage compensator, plot with shock clipper active. (Response overshoot of 500 PSI, response undershoot of 450 PSI)

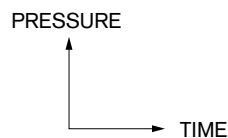

Notes:

For More Information, Contact Your Local Distributor:



Visit us on the World Wide Web at <http://www.boschfluidpower.com>

NORTH AMERICA

Bosch Automation Technology
P.O. Box 2025
Racine, Wisconsin 53401-2025 U.S.A.
Phone (414) 554-7100
Fax (414) 554-7117

EUROPE

Robert Bosch GmbH
Geschäftsbereich
Automationstechnik
Montagetechnik
Postfach 30 02 07
D-70442 Stuttgart
Telefax (0711) 811-7712

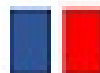

www.khadamathydraulic.com

Tell: 021-55882749

Tell: 021-33488178

Fax: 021-33488105