 www.khadamathydraulic.com
Tell: **021-55882749**
Tell: **021-33488178**
Fax: **021-33488105**

Series 20 Axial Piston Motors

Service Manual and Repair Instructions

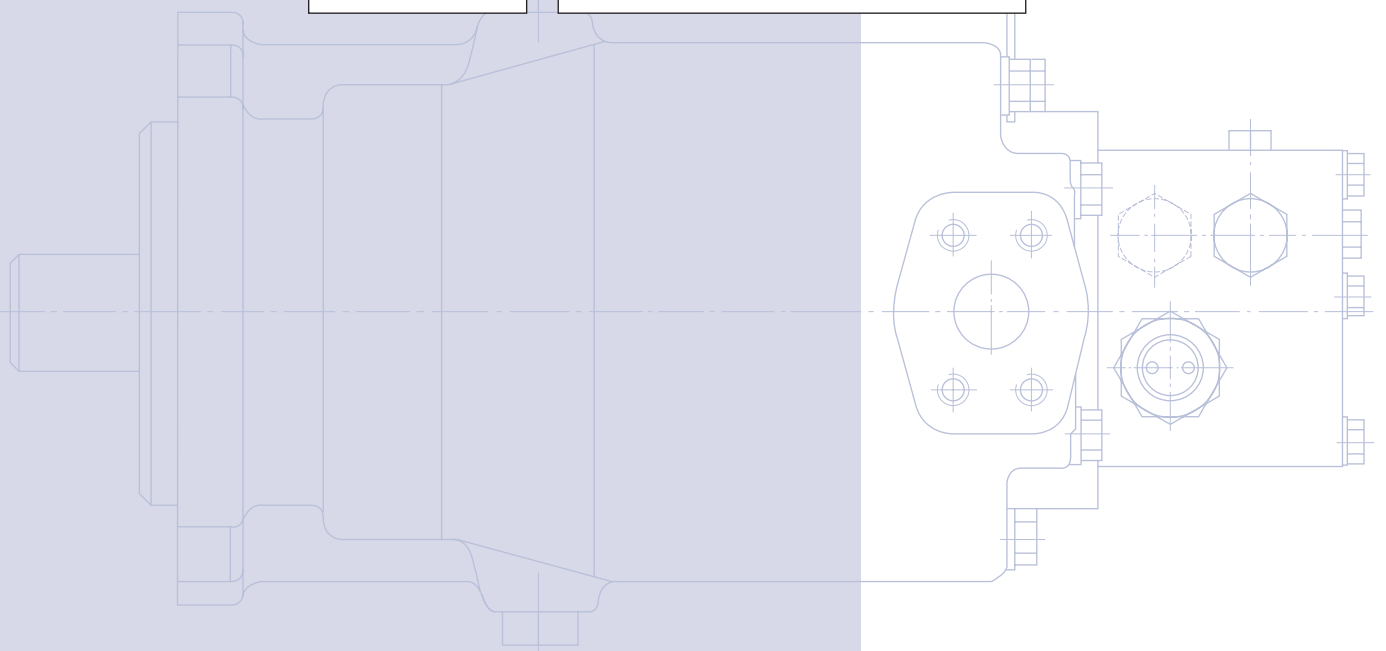
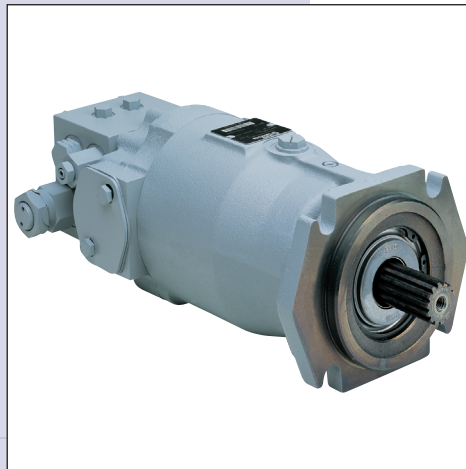
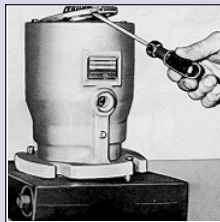
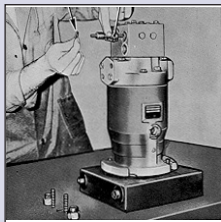

Series 20 Axial Piston Motors

Service Manual and Repair Instructions

General Information

Introduction

The purpose of this manual is to provide you with the information necessary for the normal maintenance and servicing of the Sauer-Danfoss hydrostatic series 20 units. This includes a description of the units and their components as well as troubleshooting, pressure setting and repair procedures.

Minor repairs may be performed without affecting the warranty. Major repairs performed during the warranty time could eventually affect the warranty.

To facilitate easy servicing, the unit has been designed with this in mind.

Many of the individual parts and assemblies are interchangeable throughout the entire series 20 family. This includes such items as the servo valve, the charge pumps and the manifold components.

In addition, many repairs and adjustments can be performed without having to remove the unit from the vehicle, provided that the unit is easily accessible and a thorough cleaning of the unit is possible before beginning with repairs.

Dirt or other forms of contamination are in most cases the reason for the breakdown of a hydraulic unit. Please pay attention to cleanliness, not only when making repairs, but also when putting the unit into operation, changing the oil, changing filters or any other procedures.

The following manual will provide you with comprehensive instructions for preventative maintenance and recognition of causes of failure of the axial-piston units.

Description

Sauer-Danfoss axial pistons fixed displacement motors are of swash plate design with preset displacement suitable for hydrostatic transmissions with closed loop circuit.

The output speed is proportional to the motor's input flow.

The output torque is proportional to the differential pressure applied to the main pressure ports.

The direction of motor (output) shaft rotation depends on flow input to the main pressure ports.

The full-length shaft with a highly efficient tapered roller bearing arrangement offers a high loading capacity for external radial forces.

High case pressures can be achieved without leakage even at the lowest temperatures by using suitable shaft seals.

Sauer-Danfoss axial piston units are designed for easy servicing. Complete dismantling and reassembly can be carried out with standard hand tools, and all components or sub-assemblies are replaceable.

© 2010 Sauer-Danfoss. All rights reserved.

Sauer-Danfoss accepts no responsibility for possible errors in catalogs, brochures and other printed material. Sauer-Danfoss reserves the right to alter its products without prior notice. This also applies to products already ordered provided that such alterations can be made without affecting agreed specifications. All trademarks in this material are properties of their respective owners. Sauer-Danfoss, the Sauer-Danfoss logotype, the Sauer-Danfoss S-icon, PLUS+1™, What really matters is inside® and Know-How in Motion™ are trademarks of the Sauer-Danfoss Group.

| | |
|---|---|
| General Information | Introduction2 |
| | Description2 |
| Model Code | Model Code4 |
| Recommended Tools and Installation | Tools for Minor Repairs and Unit Maintenance5 |
| | Additional Tools for Complete Stripping of Units5 |
| | Measurement Instruments5 |
| | Troubleshooting, Gauge Installation and Information6 |
| Start-up procedure | Preconditions for Trouble-free Operation7 |
| | Cleanliness7 |
| | Preconditions for trouble-free operation (continued)8 |
| | Plumbing Installation (Variable Displacement Pump - Fixed Displacement Motor)9 |
| | System Circuit Description.....10 |
| System Maintenance | Inlet Filter11 |
| | Changing the oil11 |
| | Leak Test.....11 |
| | Cleanliness11 |
| | Checking the oil level.....11 |
| | Recommended oils.....11 |
| Troubleshooting | Transmission Operates in one Direction Only12 |
| | System Response is sluggish.....12 |
| | System Operating hot.....13 |
| | System will not operate in either direction.....13 |
| | Inspection Instructions14 |
| | Checking the high pressure relief valve14 |
| | Preparation for Assembly15 |
| | Checking the shuttle valve15 |
| | Mounting block15 |
| Disassembly and Assembly | Sectional View16 |
| | Axial piston fixed displacement motor16 |
| | Exploded View17 |
| | Minor Repairs18 |
| | Changing the shaft seal (disassembly).....18 |
| | Changing the shaft seal (assembly)19 |
| | Changing the valve manifold assembly20 |
| | Repair the manifold valve assembly21 |
| | Installation Torque Values22 |
| | Changing the valve and bearing plate (disassembly)23 |
| | Changing the valve and bearing plate (assembly)24 |
| | Changing the cylinder block kit, the swash plate and the motor shaft (disassembly)..25 |
| | Changing the cylinder block kit, the swash plate and the motor shaft (assembly)27 |

Model Code

| | | | | | | | | | | | | | | | | | | |
|---|---|---|---|--|--|---|--|--|--|--|--|--|--|--|--|--|---|---|
| S | M | F | 2 | | | B | | | | | | | | | | | A | 1 |
|---|---|---|---|--|--|---|--|--|--|--|--|--|--|--|--|--|---|---|

| Series of product | |
|-------------------|---------------------|
| SMF | motor fixed |
| 2 | association type 20 |

| Producer mark | |
|---------------|--|
| A1 | producer specification according to construction (at present = A1) |

| Displacement cm ³ [in ³] | |
|---|-----------------|
| 033 | = 33.3 [2.03] |
| 052 | = 51.6 [3.15] |
| 070 | = 69.8 [4.26] |
| 089 | = 89.0 [5.43] |
| 119 | = 118.7 [7.24] |
| 166 | = 165.8 [10.12] |
| 227 | = 227.3 [13.87] |
| 334 | = 333.7 [20.36] |

| Units with working mark | |
|---|--|
| 3 - letter combination e.g.: | |
| Cxx | making all seals in Viton |
| special copies with or without mark of copy | |
| 035 | 3 - letter combination e.g. with industrial valve block, with brake pneumatic valve and all seals in Viton |

| Orientation of rotation | |
|-------------------------|------------|
| B | reversible |

| Input port | |
|-------------------------|--|
| working port SAE-flange | |
| 3 | = 3000 psi SAE J518 (207 bar) for displacement 033 - 119 cm ³ |
| 6 | = 6000 psi SAE J518 (414 bar) for displacement 166 - 334 cm ³ |

| End cap execution | | | | | | |
|---|---|--------|--------|--------|--------|--------|
| end cap (not assembled) | | | | | | |
| no entry = basic making | | | | | | |
| MS | valve block with washing function | | | | | |
| MR | additional shorting valve with connection plate | | | | | |
| AM 01000 | without valve block | | | | | |
| typical numbers for possible levels of high pressure (pressure drop) in port A and/or B | | | | | | |
| 1. characteristic number for setting of pressure port A | | | | | | |
| 2. characteristic number for setting of pressure port B | | | | | | |
| characteristic number | 07 | 10 | 14 | 17 | 21 | 24 |
| p bar | 70 | 105 | 140 | 175 | 210 | 245 |
| [psi] | [1015] | [1520] | [2030] | [2540] | [3050] | [3550] |
| characteristic number | 28 | 31 | 35 | 38 | (40)* | (42)* |
| p bar | 280 | 315 | 350 | 385 | (400) | (420) |
| [psi] | [4060] | [4570] | [5080] | [5580] | [5800] | [6090] |
| * level of high pressure in parenthesis: after application engineer approval | | | | | | |
| 2 | typical number for flushing pressure 12 bar [174 psi] (different setting of flushing pressure on request) | | | | | |

| Shaft end | |
|------------------------|---------------------------------------|
| SAE-spline shaft 16/32 | |
| Z | = 21 teeth for displacement 033 - 070 |
| | = 23 teeth for displacement 089 |
| | = 27 teeth for displacement 119 - 227 |
| | = 40 teeth for displacement 334 |
| K* | conic shaft end with toleranced key |
| | * available on request |

Order example:
 Axial piston fixed displacement motor SMF 2
 Displacement V_g = 333.7 cm³, Orientation of rotation: reversible
 Input port 6000 psi SAE J518
 SAE spline shaft 40 teeth
 End cap execution: connection plate
Order mark:
 SMF 2/334-B6Z-AM 01000-A1

Series 20 Axial Piston Motors Service Manual and Repair Instructions Recommended Tools and Installation

Tools for Minor Repairs and Unit Maintenance

- Circlip pliers \varnothing 2 to 2.5 mm
- Screw drivers 3, 6 and 9mm
- Plastic hammer - small
- Pointed pliers (can also be slightly bent)
- Torque key to 14.9 Nm [132 lbf·inch]
- Set of ring spanners $5/16$ to $1\frac{1}{4}$
- Set of Allenkeys $1/4$ to $3/8$
- Fixed spanner $1\frac{5}{6}$ for high pressure relief valve
- Puller retainer seal

Additional Tools for Complete Stripping of Units

(Major repairs should not be carried out during the warranty period.)

- Right angle screw driver 16 mm
- Set of drifts 2 to 10 mm
- Plastic hammer - large
- Bearing puller 80 x 120 mm
- Bearing puller 200 x 250 mm
- Each fixed spanner for servo cylinder 36, 41, 46, 50, 55, 60, 65 mm
- Depth gauge 300 mm
- Set of fixed or open ended spanners $7/16$ to $1\frac{1}{4}$
- Fitting block - see *page 14*

Measurement Instruments

- At least 2 pressure gauges up to 60 bar damped (charge pressure - servo pressure)
- 1 vacuum gauge to $+1.0 \div -1.0$ bar [$14.5 \div -14.5$ psi] (vacuum measurement at the charge pump)
 - 2 pressure gauges to 600 bar [8700 psi] (high pressure measurement at the valve block)
 - 1 pressure gauge to 8 bar [116 psi] (casing pressure measurement)

Additional: Torque spanners, separate order!

Series 20 Axial Piston Motors Service Manual and Repair Instructions Recommended Tools and Installation

Troubleshooting, Gauge Installation and Information

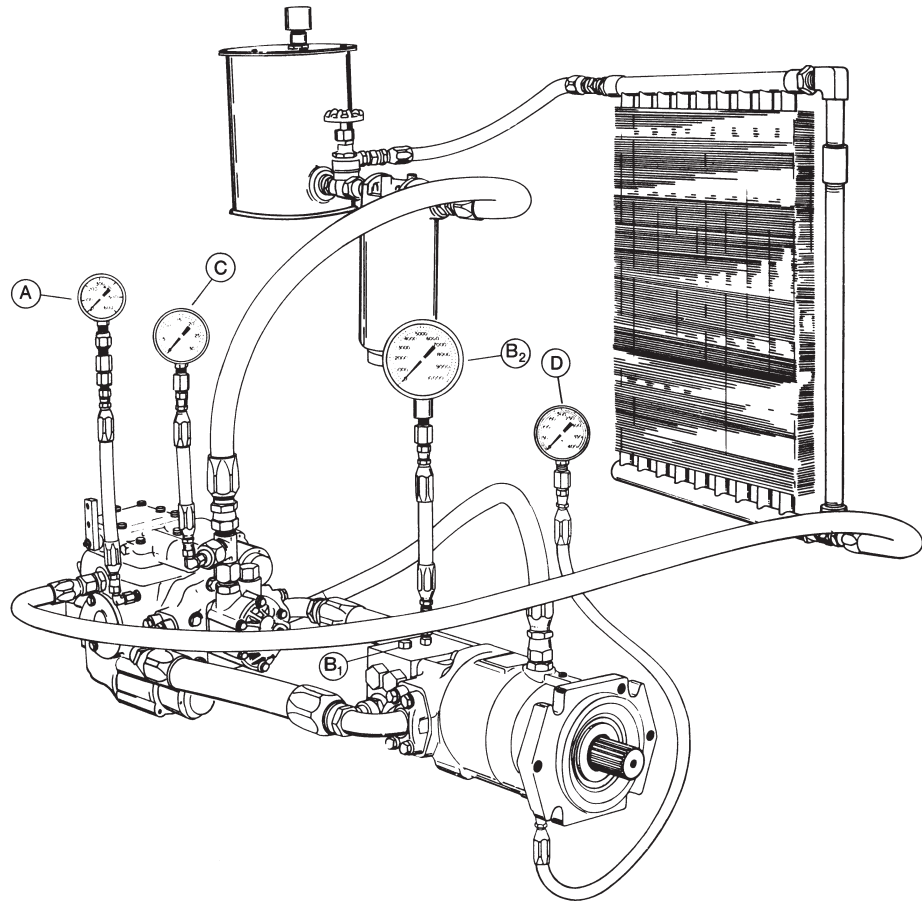

Gauge Information

| | | | |
|----------|------------------------|----------------------------|------------------------------|
| A | Charge Pressure | 60 bar [870 psi] - Gauge | 7/16 - 20 UNF O-ring Fitting |
| B | System pressure | 600 bar [8700 psi] - Gauge | 7/16 - 20 UNF O-ring Fitting |
| C | Inlet Vacuum | Vacuum gauge | Tree Into Inlet Line |
| D | Case pressure | 8 bar [116 psi] - Gauge | Adapt to Bottom Drain Port |

Series 20 Axial Piston Motors

Service Manual and Repair Instructions

Start-up procedure

Preconditions for Trouble-free Operation

Cleanliness

Ensure that the pipes, pipe connections and hoses as well as all other components are completely clean.

Ventilation and venting of the oil reservoir via an air filter.

Operating fluid

HLP fluid according to DIN 51524, ATF type A SUFFIX A, HD-SAE motor oils, see *Fluid Manufacturers, Technical Information*.

Oil level: (The inlet pipe and return flow port must always be below the surface of the oil). No funnel-shaped eddying at the inlet connection pipe. No formation of foam at the return flow pipe. The inlet connection pipe must be substantially above the bottom of the reservoir. A partition plate should be located between the inlet and return flow connection pipes.

Filtration

Filtration grade = 10 µm [394 µinch] nominal.

Inlet pressure of charge pump: 0.85 bar [12.3 psi] absolute (- 0.15 bar [-2.2 psi]) with a new filter element and at an operating temperature of approx. 50 °C [122 °F].

A charge pump inlet pressure less than 0.75 bar [10.9 psi] absolute (-0.25 bar [-3.6 psi]) is permissible for a short time with a reservoir temperature of less than 50 °C [122 °F] on a cold start in order to warm up the system under no-load.

If frequent cold starts are to be made, the system should be warmed up by a reservoir heater.

If the charge pump inlet pressure is less than 0.75 bar [10.9 psi] absolute (-0.25 bar [-3.6 psi]) on operating temperatures higher than 50 °C [122 °F], **the filters must be changed.**

A charge pump inlet pressure of less than 0.5 bar [7.3 psi] absolute (- 0.5 bar [-7.3 psi]) is not permissible.

The filter requires changing or the operating temperature is too low.

Venting the pump and motor housing as well as the connection lines and other components.

The return flow to the oil reservoir must be free of bubbles. After venting the system, check the fluid level and fill to proper level if necessary.

Carry out a leak test on the transmission (inlet line, filter, pipe and hose lines, valves, control elements, pump and motor) giving due consideration to the service life of the transmission, environmental protection and the reduction of oil consumption.

Tighten up any leaking joints and other connections while the system is not under pressure.

Pressure fluid temperature range: min. = -40 °C [-40 °F], max. = 95 °C [203 °F].

Viscosity range:

max. = 1000 mm²/s [4630 SUS*] (cSt) (for a short time only on a cold start).

min. = 7 mm²/s [49 SUS*] (cSt).

Recommended viscosity range: 12-60 mm²/s [66-278 SUS*] (cSt).

*SUS (Saybolt Universal Second)

Series 20 Axial Piston Motors

Service Manual and Repair Instructions

Start-up procedure

Preconditions for trouble-free operation (continued)

Changing the oil: The oil should be changed after max. 80-100 hours of operation, but at the latest one year after first-time operation.

The second oil change should be after max. 500 hours of operation but at the latest one year after the first change of fluid.

Thereafter, the oil should be changed every 1000 hours of operation but at least once a year. It is not permissible to mix oil.

Renew the inlet filter each time the oil is changed or when the inlet pressure of the charge pump falls below the permissible tolerance.

Clean the air filter whenever too much dirt has accumulated.

The max. speed is as specified in the catalogue **L1003621** *Series 20 Axial Piston Pumps, Technical Information* or **L1003465** *Series 20 Axial Piston Motors, Technical Information*.

First-time operation

The charge pressure measured at the charge pressure gauge connection port of the pump with the adjusting lever in the neutral position should be approx. 15 bar [217.6 psi] at a pump input speed $n = 1500 \text{ min}^{-1}$ (rpm).

The charge pressure measured at the charge pressure gauge connection port of the pump with the adjusting lever engaged should be approx. 2 bar lower at a pump input speed $n = 1500 \text{ min}^{-1}$ (rpm).

1. After installing the transmission and the corresponding pipeline connections, remove the plug from the charge pressure gauge port of the variable displacement pump. Fit a gauge with a measuring range up to 60 bar [870 psi] to this port. The charge pressure gauge port has a straight 7/16-20 UNF-2 B SAE thread.
2. Disconnect the charge pump inlet line from the charge pump inlet connection pipe.
3. Fill the pump case and the motor case with the recommended oil through the drain port.
4. Fill the oil reservoir with fluid. As soon as oil emerges from the end of the disconnected charge pump inlet line tighten the pipe connector (see *table to page 27* for the correct tightening torque) and continue to fill the reservoir. Only use oil reservoirs that are fitted with air filters.
5. Disconnect the control linkage from the control handle.
The pump must be in the zero position.
6. Allow the prime mover to turn for approx. 15 sec. by using the starter. If the prime mover is an electric motor: Switch on and off again.
7. Then start the prime mover and allow the pump to turn at idling speed (approx. 750 min^{-1}) for approx. 5 minutes.
In the case of electric prime mover: **Allow to turn for approx. 1 minute.**
After initial fluctuations in pressure, the charge pressure should settle down to 10 bar [145 psi] or 12 bar [174 psi].
8. Check the pressure fluid level.

Series 20 Axial Piston Motors Service Manual and Repair Instructions Start-up procedure

First-time operation (continued)

9. Raise the speed to approx. 1500 min⁻¹ (rpm). The gauge should now indicate a pressure of approx. 15 bar [217.6 psi].
10. If the charge pressure falls to below 8 bar [116 psi], stop the prime mover, find the fault in accordance with the trouble-shooting guide and take the appropriate remedial action.
11. Stop the prime mover and attach the control linkage to the control handle. Check the fluid level in the sight glass and fill to proper level if necessary.
12. Restart the prime mover and, under no-load, adjust the zero position by means of the control handle - or even better by the control linkage - so that in both directions final position of stroke per **L1003621** *Series 20 Axial Piston Pumps, Technical Information* is achieved.
13. Allow the prime mover to turn at 1500 min⁻¹ (rpm). The charge pressure should now be 15 bar [217.6 psi].
14. Slowly move the control handle backwards and forwards. If the pump is working properly, the charge pressure drops by about 2 bar [29 psi] from the value stated in step 13 above as the control handle initiated.
15. Allow the system to work under full load with a pump speed of approx. 1500 min⁻¹ (rpm). It must be possible to achieve the values stated in steps 13 and 14 above.
16. Check all joints and connections for leaks.
17. Stop the prime mover. Remove the gauge from the connection port. Replace the 7/16-20 UNF-2 B plug and tighten with the tightening torque stated in the table to page 27.
Check the pressure fluid level in sight glass of the reservoir and fill to proper level if necessary.
The system is now ready for operation.

Plumbing Installation (Variable Displacement Pump - Fixed Displacement Motor)

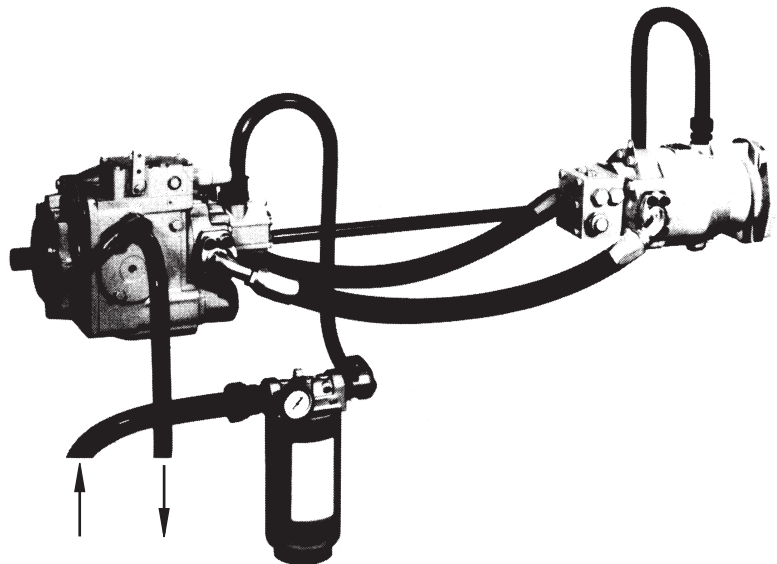

Series 20 Axial Piston Motors

Service Manual and Repair Instructions

Start-up procedure

System Circuit Description

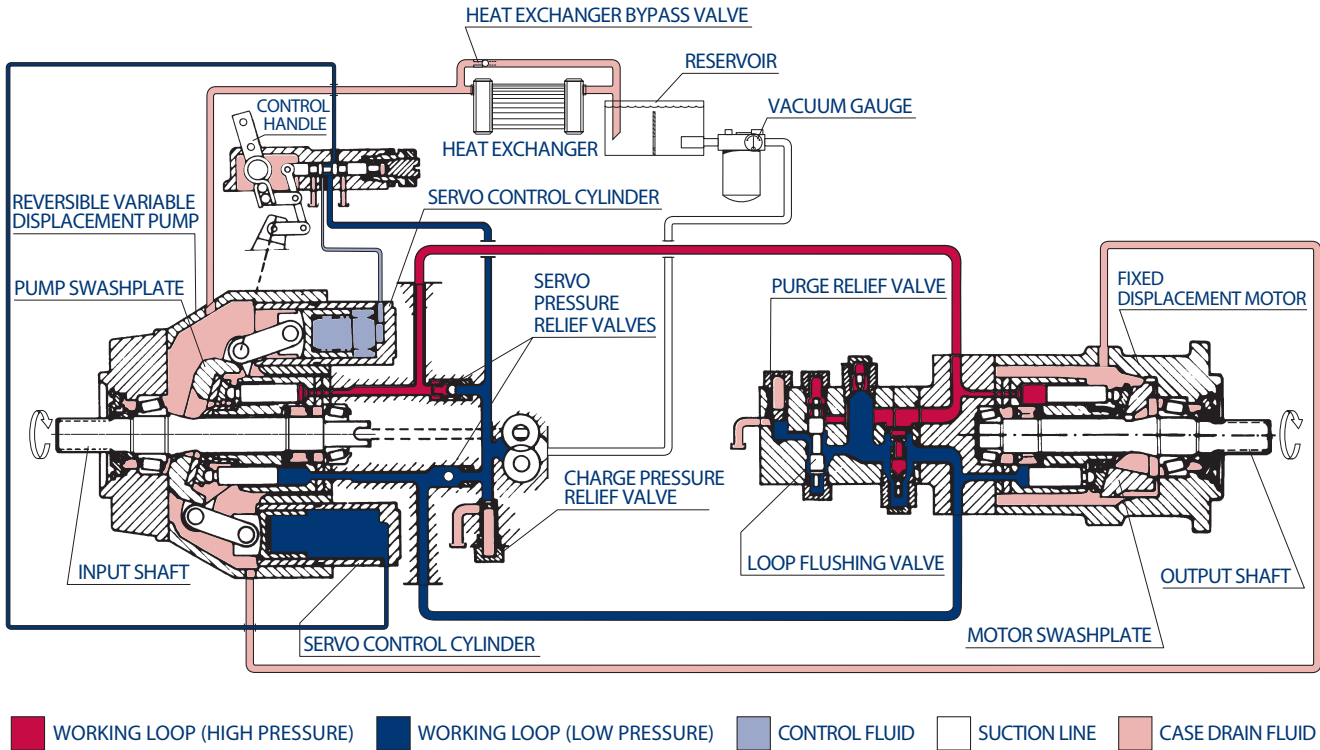

P000 027E

Inlet Filter

The filter element must be exchanged as soon as the pressure drops below 0.75 bar [10.9 psi] absolute (-0.25 bar [-3.6 psi]) when the transmission is at normal operating temperature. The filter must also be exchanged each time the pressure fluid is changed. Filtration grade = 10 µm [394 µinch] nominal.

Changing the oil

Under normal operating conditions, the oil should be changed at the following intervals: The first oil change should be carried out after max. 80-100 hours of operation but at the latest one year after first-time operation. The second change should take place after max. 500 hours of operation but at the latest one year after the first change. Thereafter, the oil should be changed at least every 1000 hours of operation or at least once a year.

To change the oil, the used fluid must be drained off when the system is at operating temperature! Remove any residual dirt or sludge from the reservoir!

In extremely dusty atmospheres, the intervals between oil changes must be correspondingly shortened.

Oil samples should be taken every 500 hours of operation. To do this, take approx. 0.5l of oil from a point on a level with the inlet (suction) connection. Fill the sample into a closable container that is free of residues.

Have the oil examined for serviceability by Sauer-Danfoss, by Oil Manufacturer or by an appropriate institution.

Important: Use only recommended oils! (See *Fluid Manufacturers, Technical Information*). It is not permissible to mix oils.

Leak Test

Carry out a leak test on the transmission (inlet line, filter, pipe and hose lines and connections, valves, control elements, pump and motor) giving due consideration to the service life of the transmission, environmental protection and reduction of oil consumption. Tighten up any leaking joint and other connections while the system is not under pressure.

Cleanliness

Make certain that the air filter for ventilation of the oil reservoir is regularly cleaned, since the input pressure may be affected if it is dirty. If there is an oil cooler, the cooler surface should be kept free from contamination. On units which have hose couplings on the connecting pipes, contamination of any sort must be avoided. Cotton rags or lint cleaning cloths may not be used for cleaning. Use only lint-free materials. When changing the oil, be sure the area around the filler cap is free from foreign objects. The oil, which can be kept clean by using a filter cloth, should be added by means of a clean funnel.

Checking the oil level

The level of the oil should be checked daily using the gauge glass. In case of loss of oil, the leak must be rectified.

Important: Use only recommended fluids! (See *Fluid Manufacturers, Technical Information*.) It is not permissible to mix.

Recommended oils

HLP - hydraulic fluids according to DIN 51524

ATF - automatic transmission fluids type A, SUFFIX A

HD - SAE motor oils

see Sauer-Danfoss manual *Fluid Manufacturers, Technical Information*.

Series 20 Axial Piston Motors

Service Manual and Repair Instructions

Troubleshooting

Transmission Operates in one Direction Only

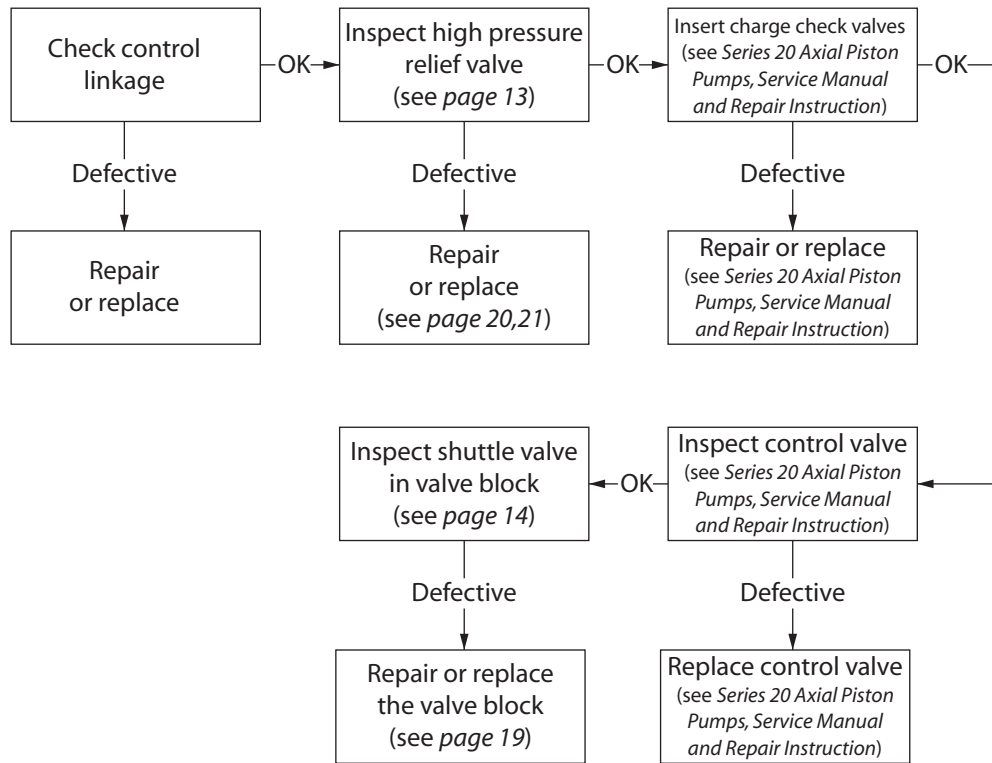

System response is sluggish

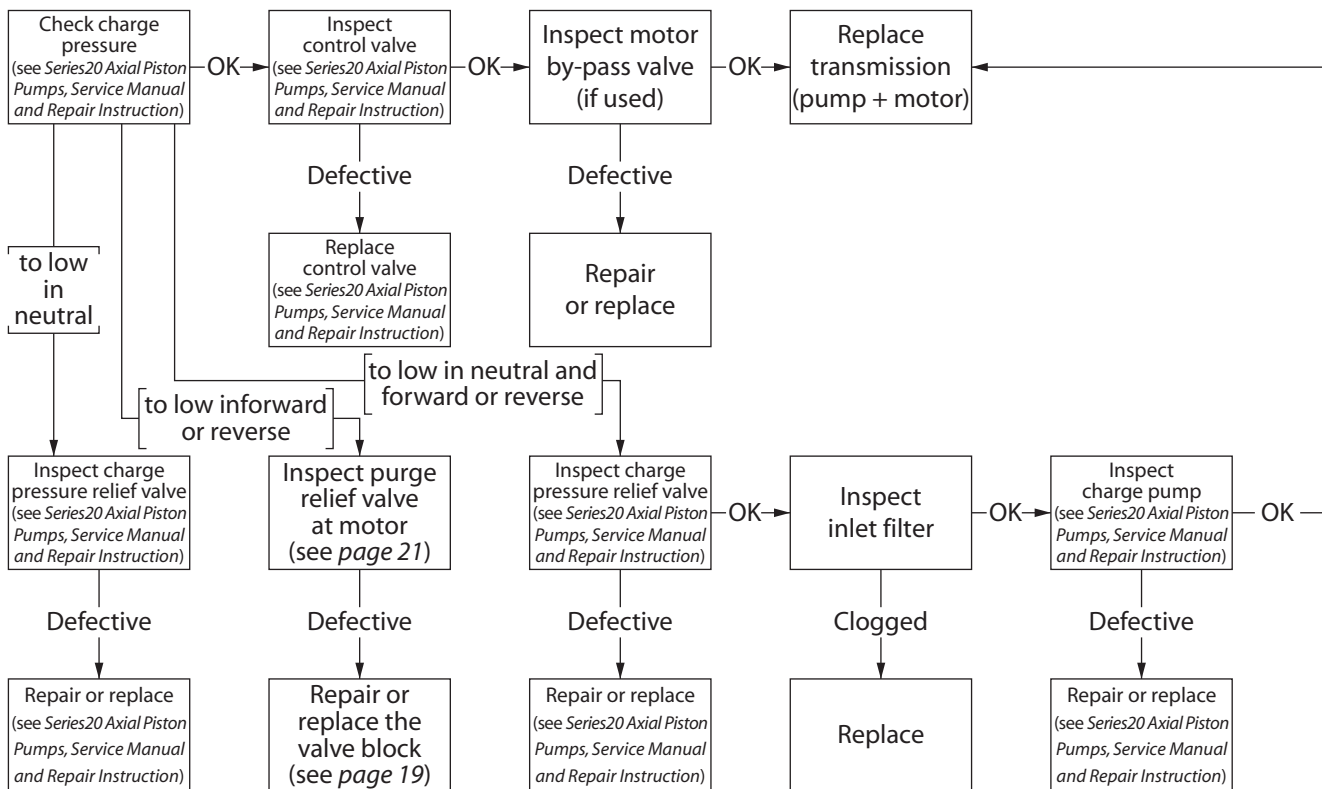

System Operating Hot

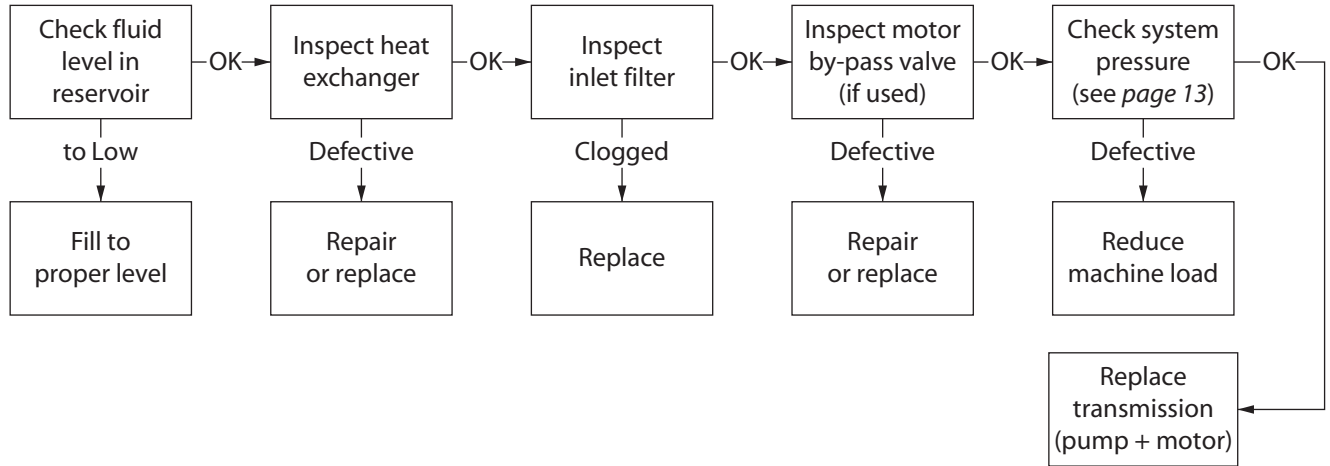

System will not Operate in either Direction

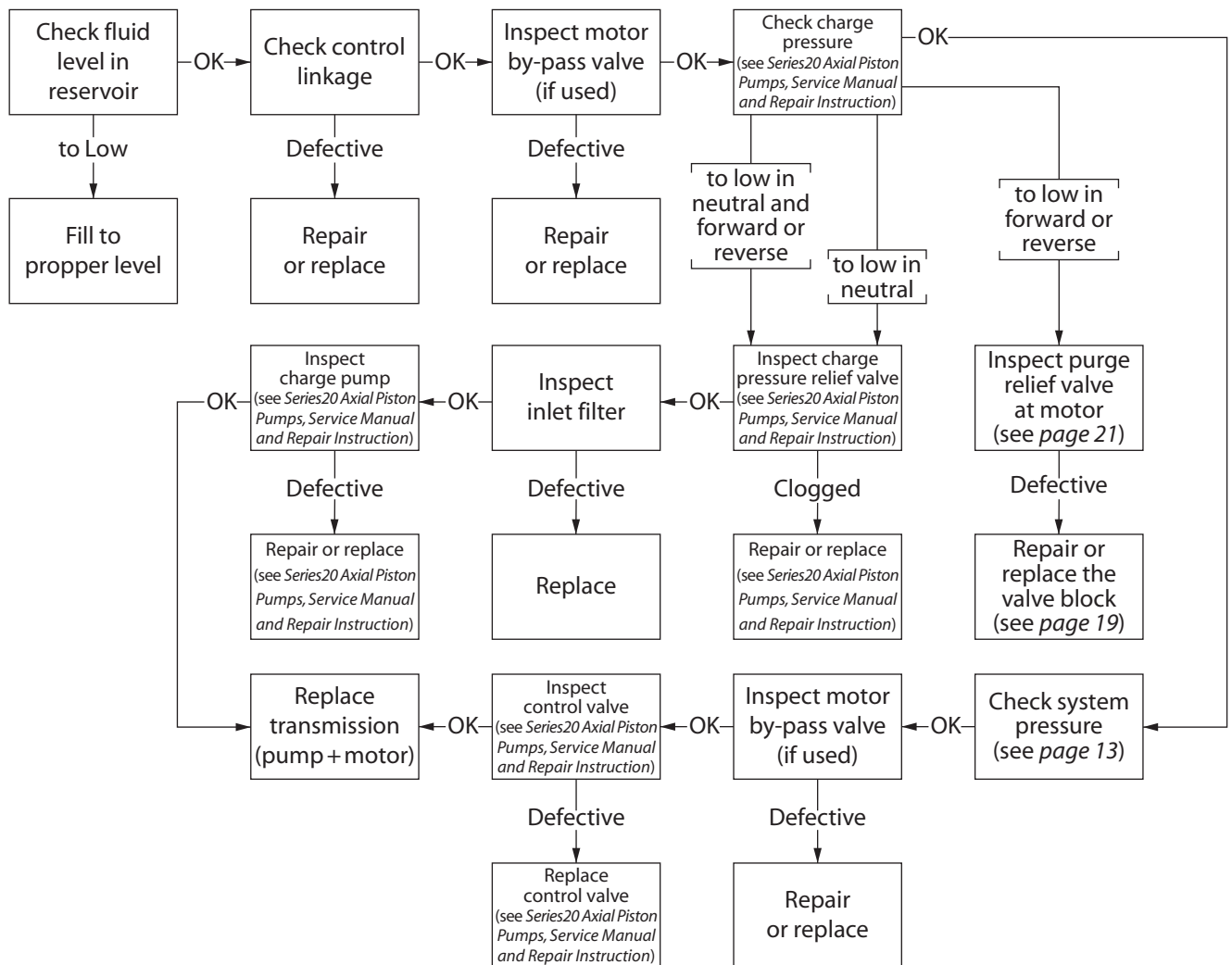

Series 20 Axial Piston Motors Service Manual and Repair Instructions Troubleshooting

Inspection Instructions

Checking the high pressure relief valve

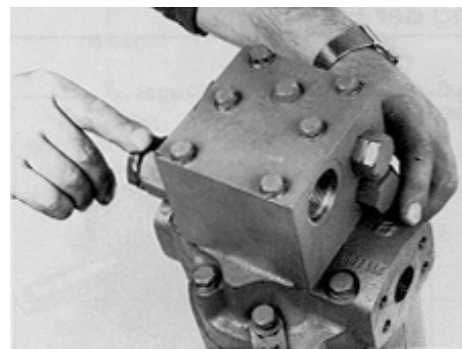
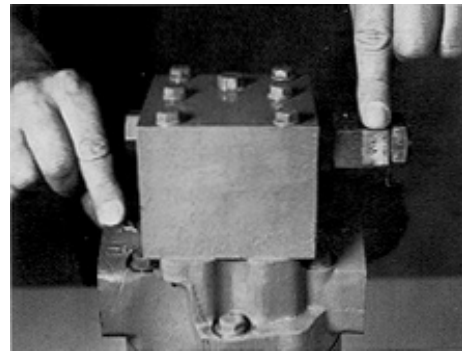
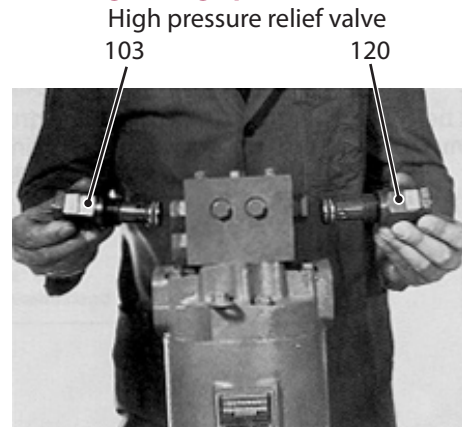

When the problem occurs in one direction only, interchange the relief valve cartridges to see if the problem changes to the other direction. If so, one relief valve cartridge is either malfunctioning or does not have the proper setting. The three (3) digits of the pressure setting are stamped on the end of the cartridge. Compare to machine specification.

⚠ Caution!

The relief valves are factory set and should not be disassembled further.

350 for 350 bar [5000 psi]

315 for 315 bar [4500 psi]

280 for 280 bar [4000 psi]

245 for 245 bar [3500 psi]

210 for 210 bar [3000 psi]

175 for 175 bar [2500 psi]

140 for 140 bar [2000 psi]

Pressure on ports A or B in accordance to high pressure relief valve setting on the opposite side to the port.

To check high pressure relief valve setting, pump should be driven under load by a prime mover with rated speed.

Stroke control lever for five seconds in both directions to final position.

Pressure setting should be in accordance to machine specification.

**Inspection Instructions
 (continued)**

Checking the shuttle valve

Washer Shuttle spool



The shuttle spool must be easily movable in the bore.

Any wear, dirt or cracks, indicate that the complete valve block needs to be replaced, the spool and manifold are matched and cannot be replaced separately (see page 20).

Mounting block

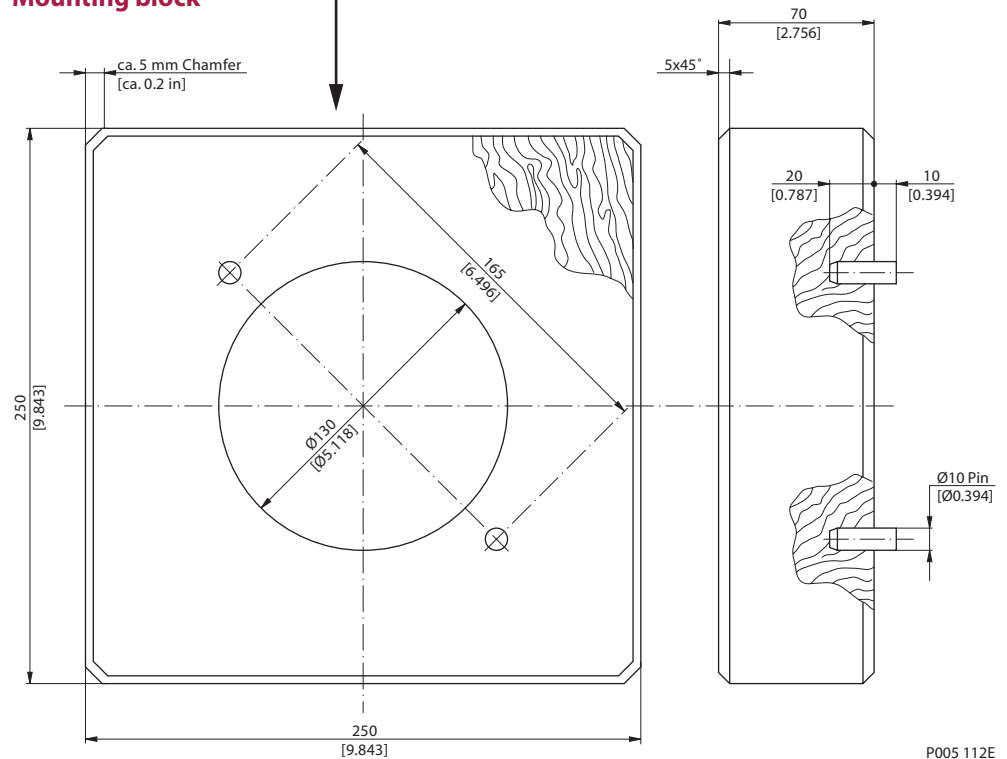

P005 112E

Preparation for Assembly

The areas of repair indicated may be serviced, following the procedures in this manual, without invalidating the warranty.

When using a lifting device, the hooks at the end of the slings, are to be fastened in the rings fitted at the front and rear of the motor body.

It is recommended that an mounting block should be used in order to facilitate a professional operation.

Series 20 Axial Piston Motors

Service Manual and Repair Instructions

Disassembly and Assembly

Sectional View

Axial piston fixed displacement motor

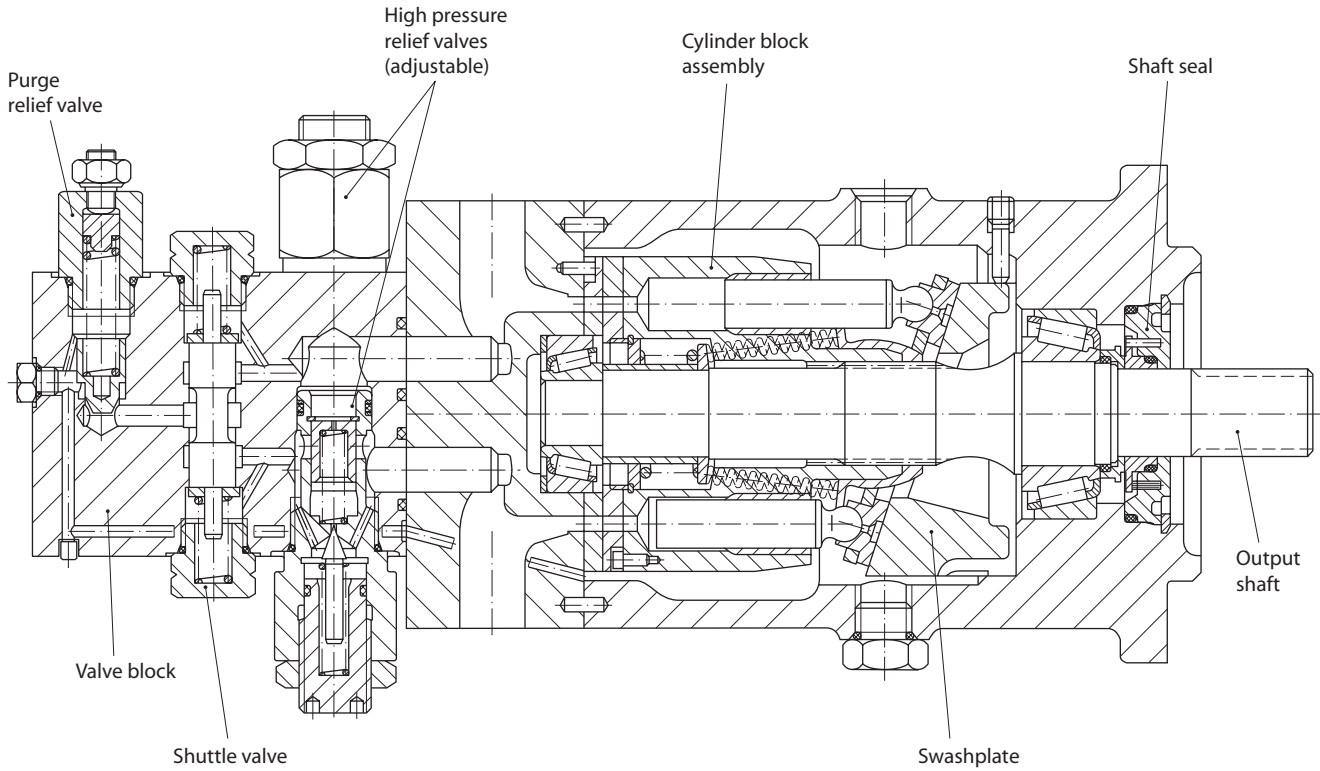

Exploded View

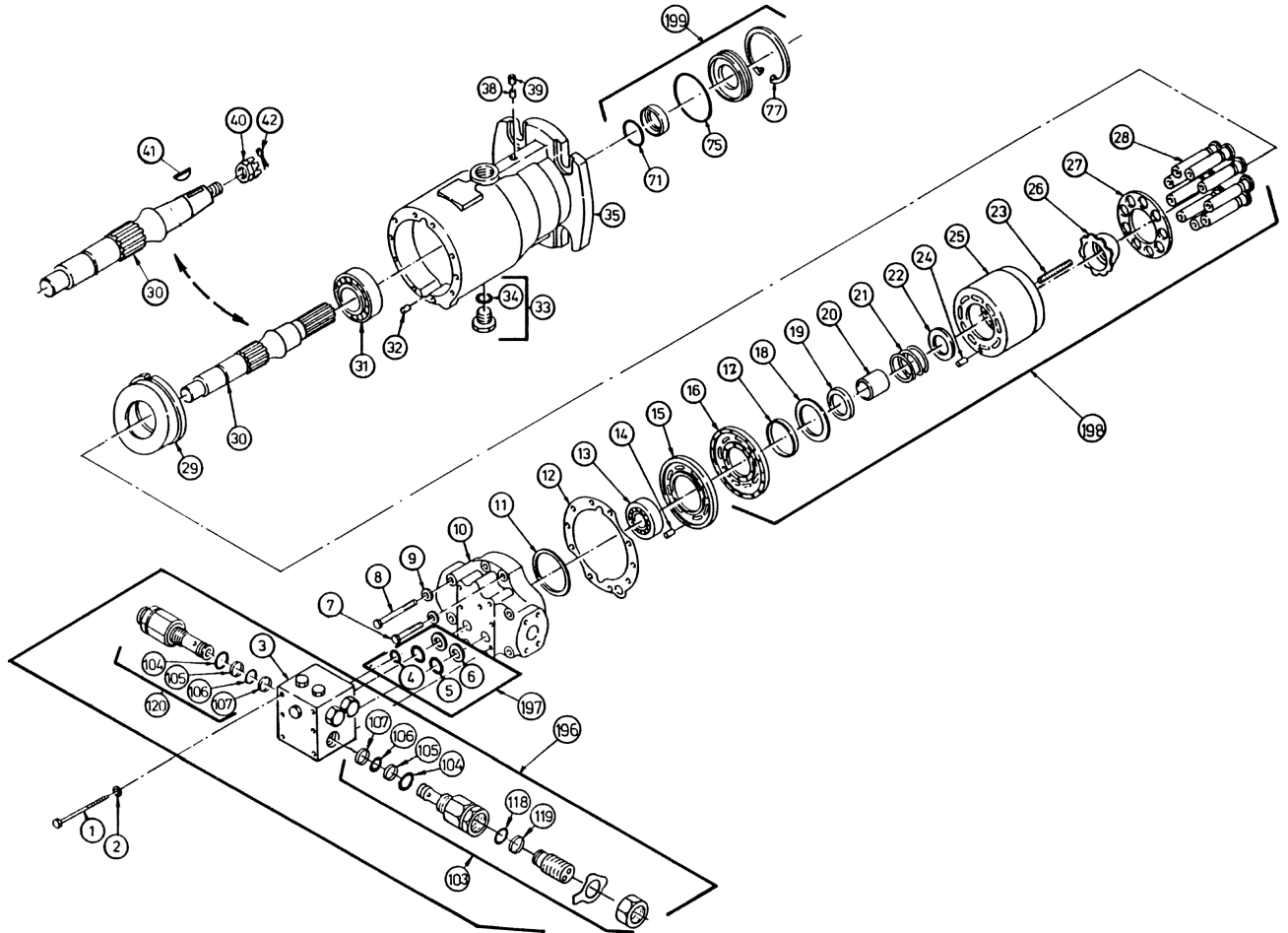

Description of parts:

- | | | |
|-----------------------------|---------------------|----------------------------------|
| 1 Hexagonal screw | 19 Retainer spring | 39 Plug-pipe |
| 2 Washer | 20 Spring guide | 71 O-ring |
| 3 Kit manifold valve | 21 Spring | 75 O-ring |
| 4 O-ring | 22 Spring seat | 77 Ring retaining |
| 5 O-ring | 23 Retainer spring | 103 High pressure valve assembly |
| 6 Back up ring | 24 Cylindrical pin | 104 O-ring |
| 7 Hexagonal screw | 25 Cylinder block | 105 Back up ring |
| 8 Hexagonal screw | 26 Retainer guide | 106 O-ring |
| 9 Washer | 27 Slipper retainer | 107 Back up ring |
| 10 End cap | 28 Piston assembly | 118 O-ring |
| 11 Shim | 29 Swash plate | 119 Back up ring |
| 12 Gasket | 30 Shaft | 120 High pressure valve assembly |
| 13 Bearing | 31 Bearing | 196 Compl. manifold assembly |
| 14 Cylindrical pin | 32 Cylindrical pin | 197 Seal kit |
| 15 Valve plate | 33 Plug | 198 Cylinder block kit |
| 16 Bearing plate | 34 O-ring | 199 Shaft seal kit |
| 17 Bearing plate pilot ring | 35 Motor housing | |
| 18 Ring retaining | 38 Cylindrical pin | |

Series 20 Axial Piston Motors Service Manual and Repair Instructions Disassembly and Assembly

Minor Repairs

Changing the shaft seal (disassembly)

Utilize the lifting gear and mounting block in accordance with the fitting instructions on page 14.

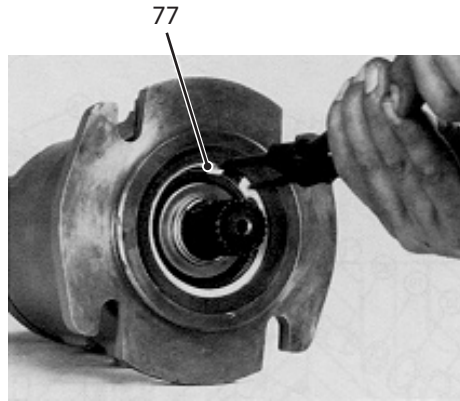

It is recommended that all shaft seal parts be replaced. If parts are to be reused, they must be protected from being damaged by the shaft during removal. Remove the large retaining ring located on the shaft end of the motor. Remove the side opposite the tangs from the groove first.

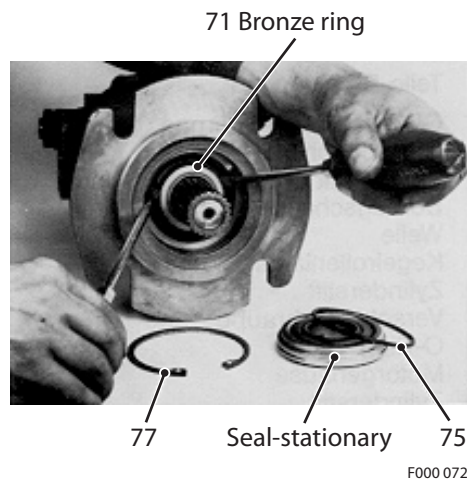

The rotating seal ring (bronze ring) is also held in its position by the O-ring. It can be removed with the help of two screw drivers.

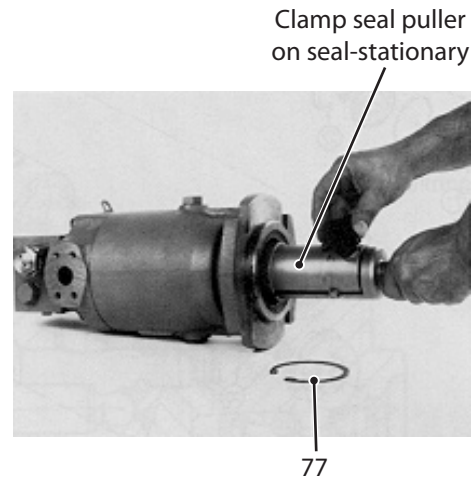

The seal-stationary is removed next. It is held in place by the friction of the O-ring on its O. D. Remove seal-stationary with the help of a seal puller to prevent damage to outer edge.

⚠ Caution!

These parts can be easily damaged. Use care in handling. Each part should be inspected separately if parts are to be reused. Always replace the O-rings. Lubricate the small O-ring with petroleum jelly and insert into the I. D. of the bronze rotating ring. Lubricate the large O-ring and place the O. D. of the seal-stationary.

**Minor Repairs
(continued)**

Changing the shaft seal (assembly)

71 Bronze ring

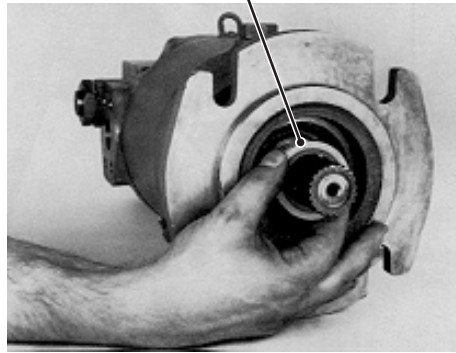

Slide the bronze sealing ring over the shaft and onto the shaft pilot diameter with the O-ring facing the unit. Work the ring into place using hand force only.

⚠ Caution!

Protect parts from damage by the shaft.

Seal stationary
Cone bearing

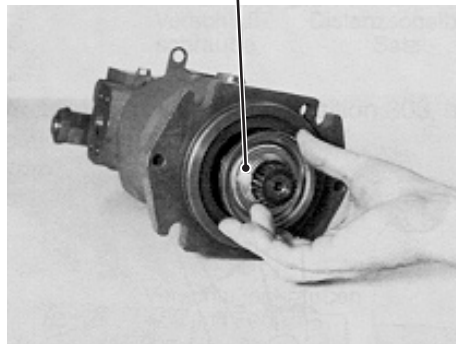

Clamp seal puller
on seal-stationary

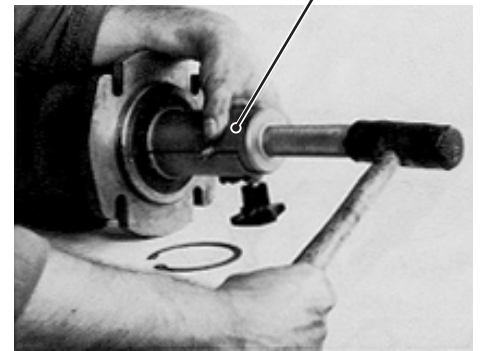

Slide seal-stationary into place against the bronze sealing ring.

77

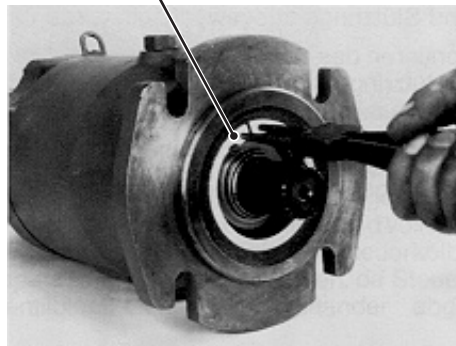

Compress the seal-stationary to expose the retaining ring groove. Install the retaining ring with the beveled side out, putting the side opposite the tangs into the groove first. Be certain that the retaining ring has snapped into the groove completely.

Series 20 Axial Piston Motors Service Manual and Repair Instructions Disassembly and Assembly

Minor Repairs (continued)

Changing the valve manifold assembly

Torque spanner

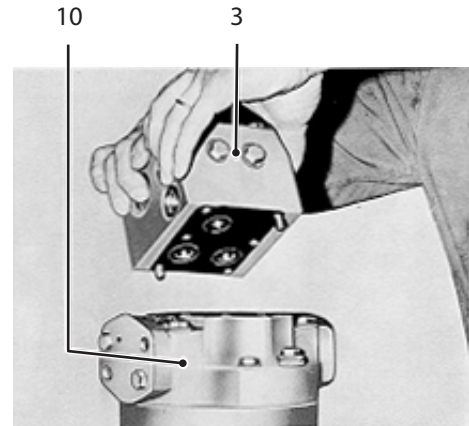
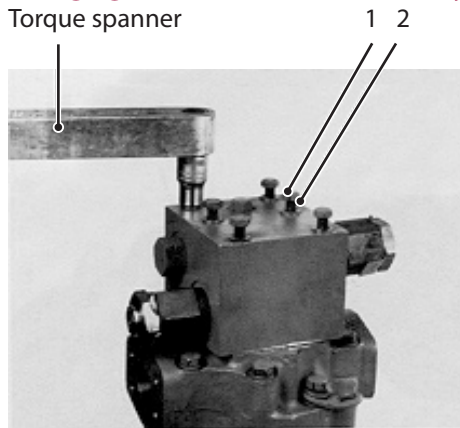

The valve manifold assembly can be removed from the motor and replaced in its entirety. The following procedure shows removal of the entire manifold from the motor before performing further disassembly.

Remove the six (6) hex. cap screws and lift the manifold off the motor end cap.

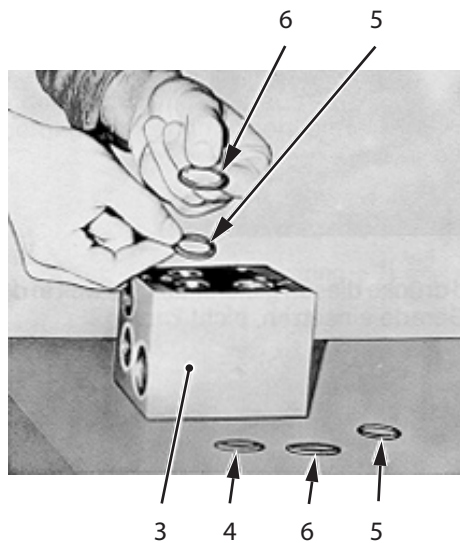

The three (3) ports are sealed with O-rings and the two (2) adjacent ports also have back-up rings on top of the O-rings. These are rectangular in cross-section and slightly cupped on one side where they mate with the O-rings.

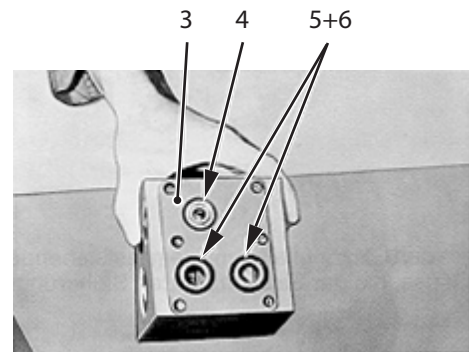

The O-ring should be placed in the port with the full counterbore. The O-rings and back-up rings fit in the ports with the machined grooves. The O-ring should be installed first and then the back-up ring.

Resume re-assembly procedure.

**Minor Repairs
 (continued)**

Repair the manifold valve assembly

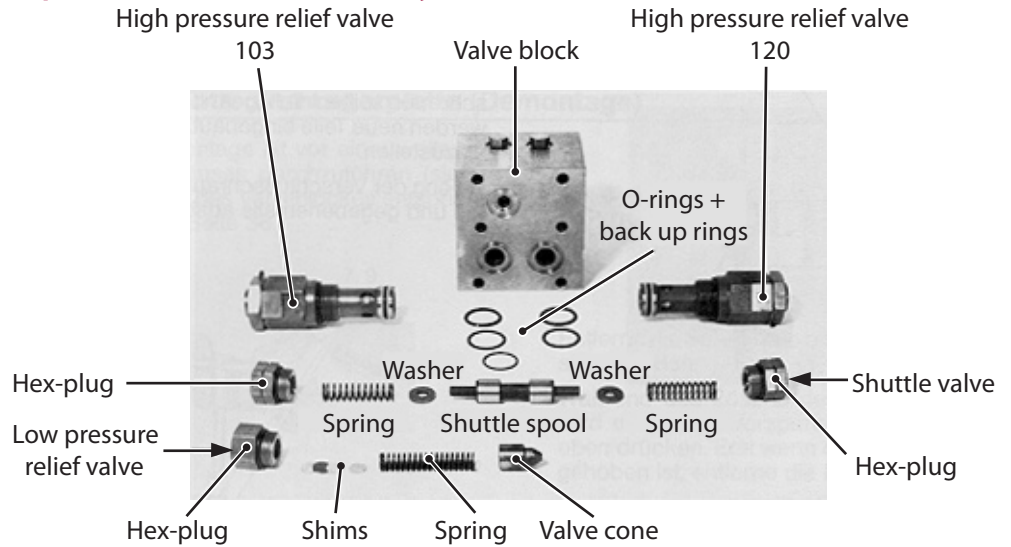

Shuttle spool, valve cone and manifold housing are matched and should not be replaced separately.

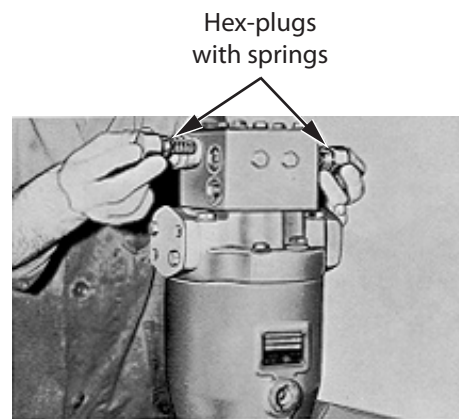

To repair the shuttle valve, remove both hex. plugs, springs, washers and spool from the manifold. These parts are interchangeable and can be installed on either side of the manifold. The spool and manifold are a select fit and must be replaced together.

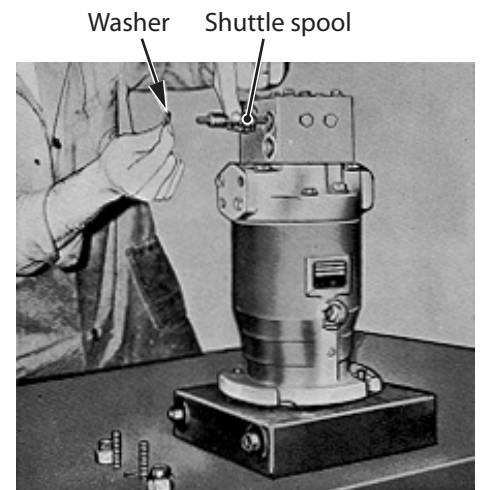

To install, slide the spool into the bore, place a washer on each end, then slide both springs in place. Install the hex. plugs and tighten.

Series 20 Axial Piston Motors Service Manual and Repair Instructions Disassembly and Assembly

Minor Repairs (continued)

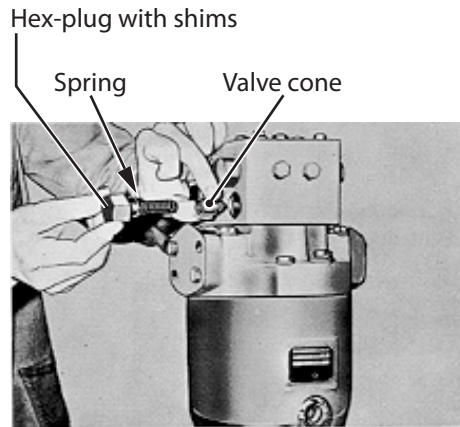

To repair the charge relief valve, remove the hex-plug, spring and valve cone. Remove the shims from the counter bore of the hex-plug. Do not alter these shims unless new parts are used, in which case the valve must be re-shimmed to the proper setting. To re-install, insert the valve cone, spring and plug, being certain the shims are in place.

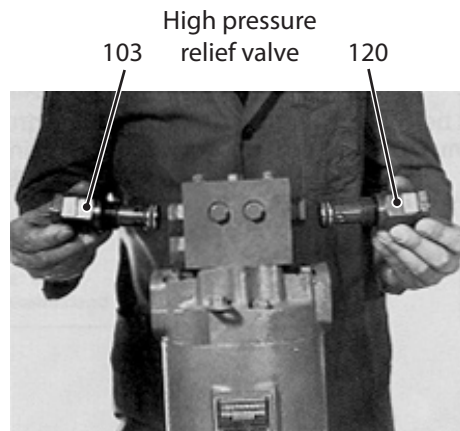

The high-pressure relief valves are cartridges that are removed by unscrewing them from the manifold. These valves are factory set and the three (3) numbers of the pressure setting are stamped on the end of the cartridge. These valves are interchangeable and can be installed in either side of the manifold, providing the pressure settings are the same.

Installation Torque Values

Installation torque values Nm [lbf·in], series 20

| | Frame size | | | |
|-------------------------|--------------------------|-----------------------------|-----------------------------|-----------------------------|
| | 033 | 052 | 070 | 089 |
| Valve manifold assembly | 21.7 [192] - 28.5 [252] | 21.7 [192] - 28.5 [252] | 21.7 [192] - 28.5 [252] | 21.7 [192] - 28.5 [252] |
| End cap | 36.6 [324] - 50.2 [444] | 36.6 [324] - 50.2 [444] | 36.6 [324] - 50.2 [444] | 61.0 [540] - 73.2 [648] |
| | Frame size | | | |
| | 119 | 166 | 227 | 334 |
| Valve manifold assembly | 21.7 [192] - 28.5 [252] | 90.9 [805] - 111.2 [984]* | 90.9 [805] - 111.2 [984]* | 90.9 [805] - 111.2 [984]* |
| End cap | 90.9 [805] - 111.2 [984] | 181.7 [1608] - 223.7 [1980] | 325.4 [2880] - 393.2 [3480] | 325.4 [2880] - 393.2 [3480] |

* large valve, manifold assembly

**Minor Repairs
(continued)**

Changing the valve and bearing plate (disassembly)

⚠ Caution!

Major repairs may affect the unit warranty, therefore equipment manufacturer should be consulted prior to undertaking such repairs.

The end cap crews should not be loosened until the shaft seal has been removed (see page 17). Remove the valve manifold assembly as outlined under minor repair procedures (see page 19).

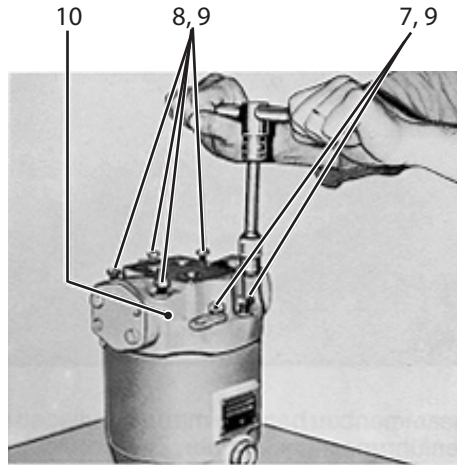

Remove all but two (2) of the hex. screws holding the end cap to the housing. There is an internal spring loading on the end cap and as the last two (2) screws are loosened, it should begin to separate from the housing. Loosen these screws alternately until the end cap has fully separated from the housing, then remove the screws entirely.

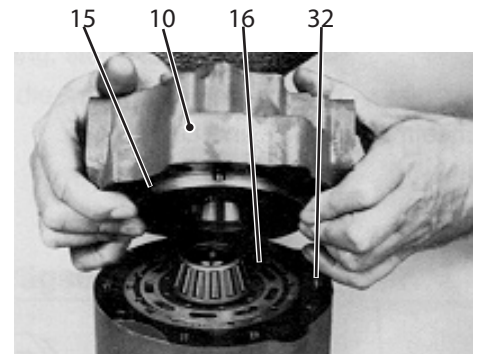

The end cap can now be lifted off the motor; however, be certain that the valve plate does not fall and become damaged. If the valve plate tends to lift off with the end cap, hold it in place on the end cap and remove both parts together. If the valve plate remains on the bearing plate, remove it at this time.

All surfaces must be treated with the greatest care. Any damage to the surfaces must be avoided at all costs.

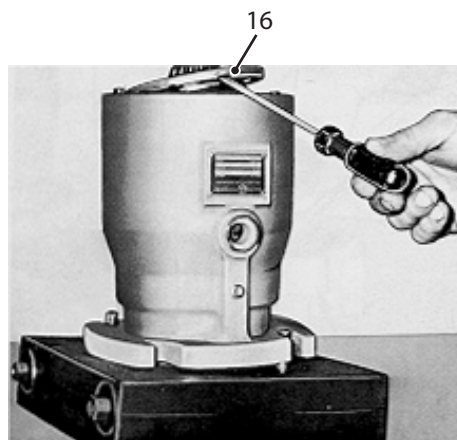

Remove the bronze bearing plate and pilot ring from the cylinder block. If the pilot ring remains with the bearing plate, remove it at this time.

Series 20 Axial Piston Motors Service Manual and Repair Instructions Disassembly and Assembly

Minor Repairs (continued)

Changing the valve and bearing plate (assembly)

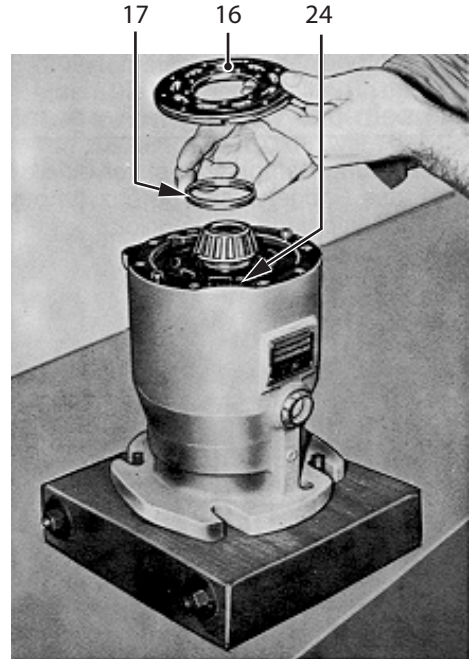
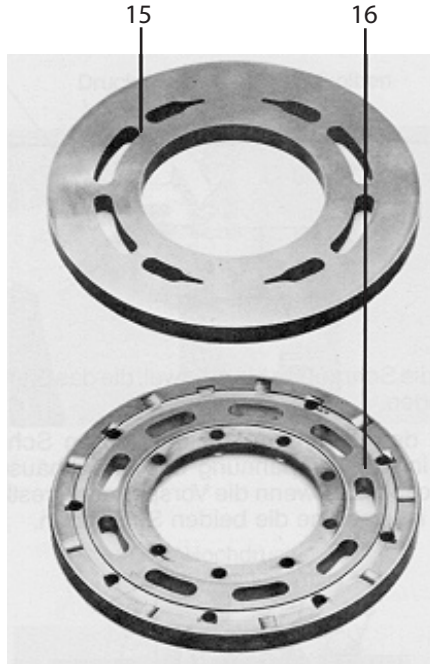

Renewing the valve- and bearing plates.

Install the pilot ring and the locating pin in the cylinder block.

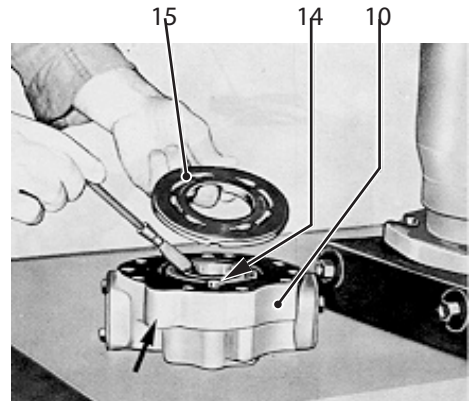
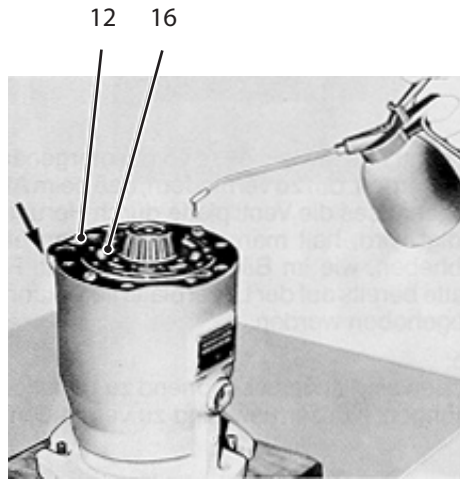

Install the bearing plate so that the milled slot locates over the pin and the pilot ring fits in the center bore of the cylinder block. After installation lubricate the exposed surfaces with clean oil.

Assemble the bearing race shim (if required) and locating pin in the end cap. Lubricate the end cap face with clean oil. Install the valve plate so that the milled slot locates over the pin and the center bore fits over the protruding bearing case. Check the valve plate to be certain it is a motor valve plate (has 4 tapered slots).

**Minor Repairs
 (continued)**

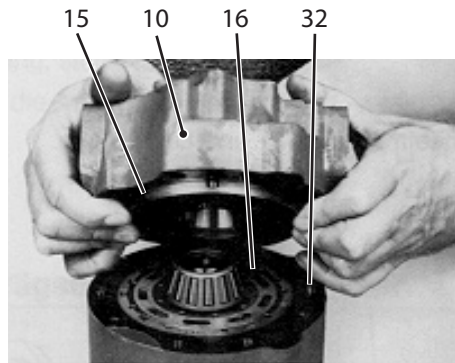

Place the end cap gasket on the housing, being certain the locating pins are in place, then install the end cap and valve plate. Hold the valve plate so it does not drop off during assembly. The end cap and gasket will only align with housing mounting holes in one position.

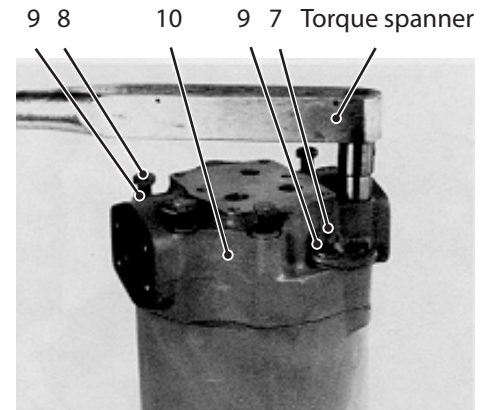

Install two (2) end cap screws and alternately tighten them until the internal spring has compressed far enough for the end cap to rest on the housing. Install the remaining screws. Install the shaft seal and valve manifold as outlined in the minor repair procedures.

Changing the cylinder block kit, the swash plate and the motor shaft (disassembly)

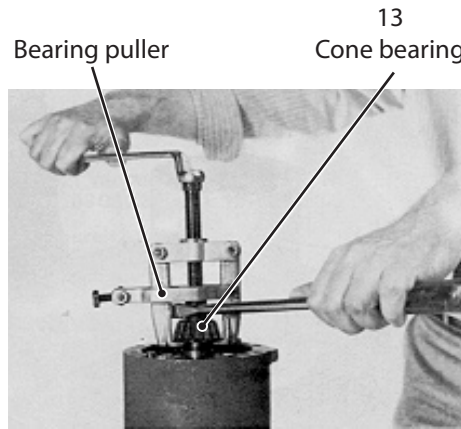

In order to replace the cylinder block unit, the shaft seal (page 17), the valve block (page 19) and the end cap (page 22), must first be removed. The tapered bearing must now be removed from the shaft. A bearing puller should be used that will pull against the inner race of bearing. Protect the cylinder block face during this operation.

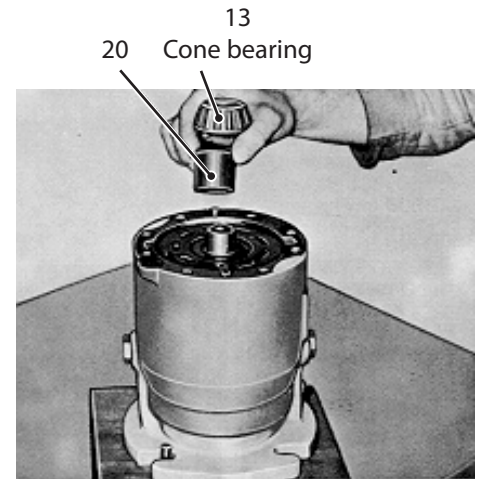

After removal of the bearing, slip the spacer out of the bore in the cylinder block.

Series 20 Axial Piston Motors Service Manual and Repair Instructions Disassembly and Assembly

Minor Repairs (continued)

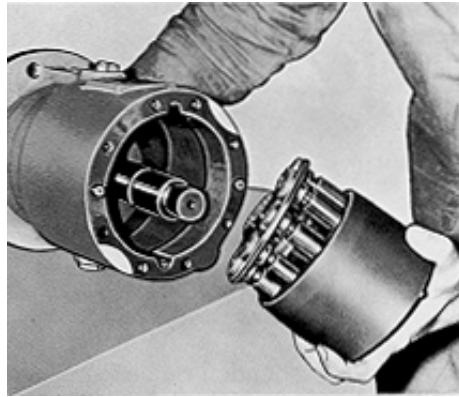

Place the motor in a horizontal position. Slide the cylinder block assembly off the shaft while holding the external end of the shaft.

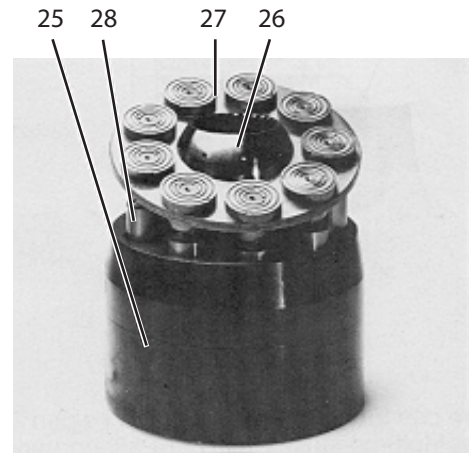

Depending upon the extent of damage, the cylinder block should be replaced complete or certain parts exchanged as the case may be. Any part of the block can be changed if necessary.

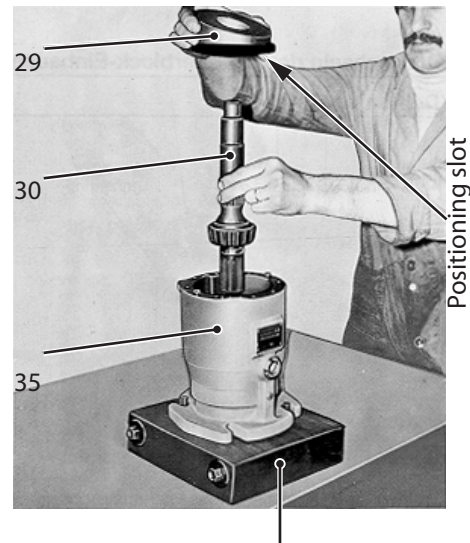
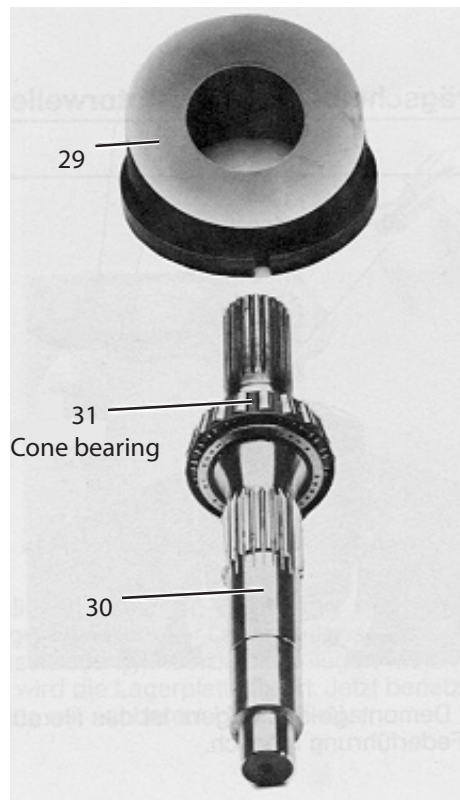

see page 14

Mount the swash plate with shaft.

If the surface is damaged, the swash plate must be exchanged.
 If the swash plate is removed, the motor shaft can also be removed.
 If the bearings are damaged, the bearing cup in the motor housing as well as the bearing on the shaft, must be changed.

**Minor Repairs
 (continued)**

Changing the cylinder block kit, the swash plate and the motor shaft (assembly)

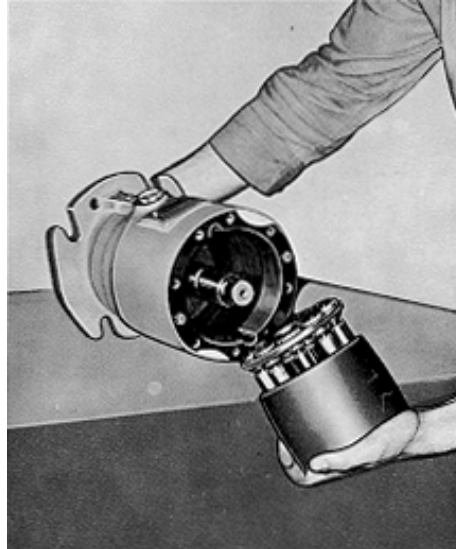

Lubricate the swash plate, slippers, pistons and bores with clean oil. Hold the shaft on the external end, align the missing shaft tooth with the missing ball guide tooth using the locating pin hole as a guide. Slide the cylinder block assembly onto shaft and against swash plate face.



see page 14

Set the motor vertically and install the spacer in the center before of the cylinder block.

Bearing puller

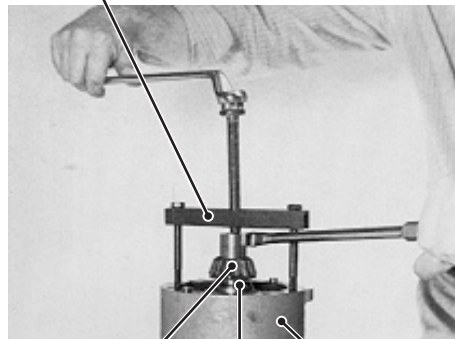

13 30 35
 Cone bearing

An alternate method of installing this bearing is to use the bearing puller bar and press the bearing onto the shaft with the center screw of the puller bar. A spacer must be used between the center screw and the bearing. The bearing must be pressed on until it rests on the shoulder of the shaft to insure adequate bearing clearance.

To check the shaft end play, assemble the shaft and bearings housing, end cap and gasket (see pages 23, 24, 19 and 18). The shaft end play should be from 0.08 to 0.18 mm [0.003 - 0.007 in] for frame sizes 033 - 089 and from 0.15 to 0.3 mm [0.006 - 0.012 in] for frame sizes 119 - 334. If adjustment is necessary, a shim can be placed under the bearing race in the end cap.

www.khadamathydraulic.com

Tell: 021-55882749

Tell: 021-33488178

Fax: 021-33488105

Products we offer:

- Bent Axis Motors
- Closed Circuit Axial Piston Pumps and Motors
- Displays
- Electrohydraulic Power Steering
- Electrohydraulics
- Hydraulic Power Steering
- Integrated Systems
- Joysticks and Control Handles
- Microcontrollers and Software
- Open Circuit Axial Piston Pumps
- Orbital Motors
- PLUS+1™ GUIDE
- Proportional Valves
- Sensors
- Steering
- Transit Mixer Drives

Members of the Sauer-Danfoss Group:

Comatrol

www.comatrol.com

Schwarz Müller-Inverter

www.schwarzmueller-inverter.com

Turolla

www.turollaocg.com

Hydro-Gear

www.hydro-gear.com

Sauer-Danfoss-Daikin

www.sauer-danfoss-daikin.com

Sauer-Danfoss is a global manufacturer and supplier of high-quality hydraulic and electronic components. We specialize in providing state-of-the-art technology and solutions that excel in the harsh operating conditions of the mobile off-highway market. Building on our extensive applications expertise, we work closely with our customers to ensure exceptional performance for a broad range of off-highway vehicles.

We help OEMs around the world speed up system development, reduce costs and bring vehicles to market faster.

Sauer-Danfoss – Your Strongest Partner in Mobile Hydraulics.

Go to www.sauer-danfoss.com for further product information.

Wherever off-highway vehicles are at work, so is Sauer-Danfoss.

We offer expert worldwide support for our customers, ensuring the best possible solutions for outstanding performance. And with an extensive network of Global Service Partners, we also provide comprehensive global service for all of our components.

Please contact the Sauer-Danfoss representative nearest you.

Local address:

Sauer-Danfoss (US) Company
2800 East 13th Street
Ames, IA 50010, USA
Phone: +1 515 239 6000
Fax: +1 515 239 6618

Sauer-Danfoss ApS
DK-6430 Nordborg, Denmark
Phone: +45 7488 4444
Fax: +45 7488 4400

Sauer-Danfoss GmbH & Co. OHG
Postfach 2460, D-24531 Neumünster
Krokamp 35, D-24539 Neumünster, Germany
Phone: +49 4321 871 0
Fax: +49 4321 871 122

Sauer-Danfoss-Daikin LTD.
Shin-Osaka TERASAKI 3rd Bldg. 6F
1-5-28 Nishimiyahara, Yodogawa-ku
Osaka 532-0004, Japan
Phone: +81 6 6395 6066
Fax: +81 6 6395 8585