



www.khadamathydraulic.com

Tell: 021-55882749

Tell: 021-33488178

Fax: 021-33488105



Series 90 Pumps

Service Manual

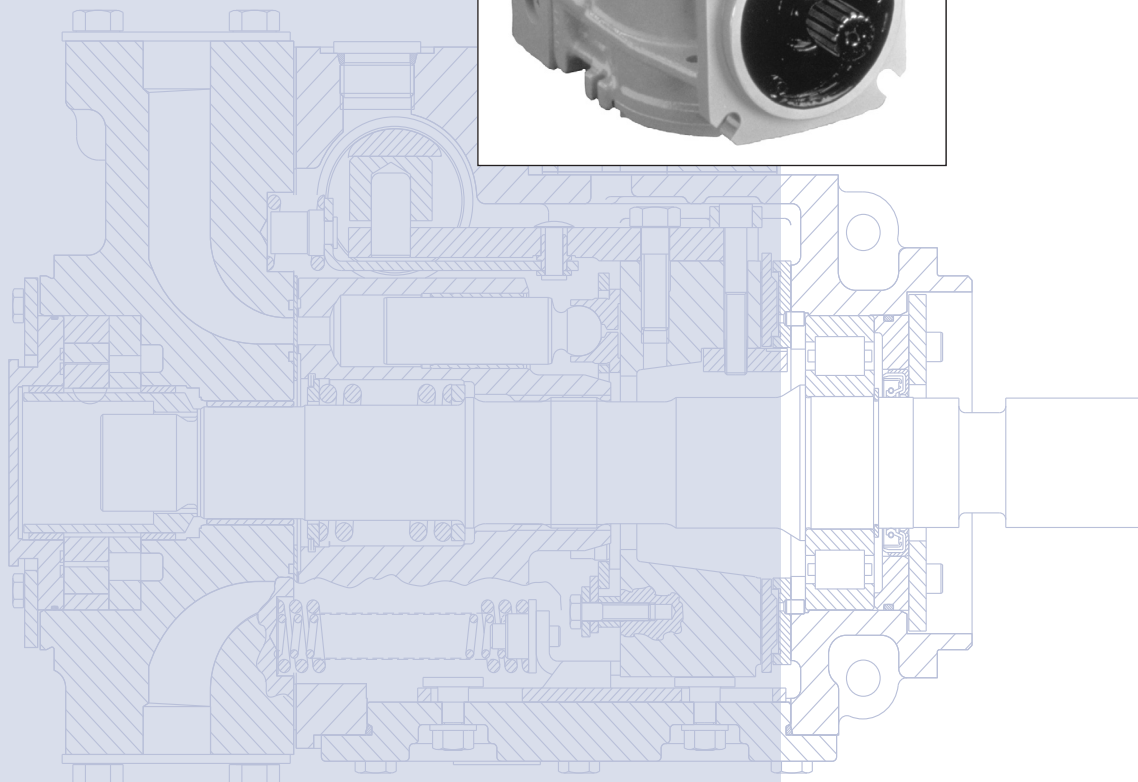
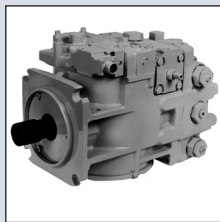



HISTORY OF REVISIONS

Table of Revisions

Date	Page	Changed	Rev.
December 2011	69	Torque values changed for E60	AC
April 2008	70	Torque for G45, G50, G52, G54, B70, B72, B82, B83 changed to 40 Nm [30 lbf·ft]	AB
September 2007	-	First printing - replaces BLN-9947	AA

© 2011 Sauer-Danfoss. All rights reserved.

Sauer-Danfoss accepts no responsibility for possible errors in catalogs, brochures and other printed material. Sauer -Danfoss reserves the right to alter its products without prior notice. This also applies to products already ordered, provided that such alterations can be made without affecting agreed specifications. All trademarks in this material are properties of their respective owners. Sauer-Danfoss, the Sauer-Danfoss logotype, the Sauer-Danfoss S-icon, PLUS+1™, What really matters is inside® and Know-How in Motion™ are trademarks of the Sauer-Danfoss Group.



INTRODUCTION

Overview6
 Warranty6
 General instructions6
 Safety precautions7
 Unintended machine movement7
 Flammable cleaning solvents7
 Fluid under pressure7
 Personal safety7
 Symbols used in Sauer-Danfoss literature8
 Design9
 The system circuit.....10

OPERATION

Charge pump12
 Charge relief valve.....12
 Multi-function valves12
 Pressure limiter and high pressure relief valves13
 System check valves13
 Bypass valves13
 Speed sensors.....13
 Filtration options14
 Pressure override (POR) – 180 frame size only.....14
 Manual displacement control (MDC)15
 Non-linear MDC15
 Solenoid override valve for MDC15
 Neutral start switch (NSS).....15
 Hydraulic displacement control (HDC).....15
 Electric displacement control (EDC)15
 Automotive control (FBA II B).....15
 3-Position (FNR) electric control15

**OPERATING
 PARAMETERS**

Overview16
 Input speed16
 System pressure.....16
 Charge pressure.....17
 Charge inlet pressure17
 Case pressure17
 Temperature and viscosity.....18
 Temperature18
 Viscosity.....18
 Fluid and filter recommendations.....19

**TECHNICAL
 SPECIFICATIONS**

Overview20
 Features and options20
 Operating parameters20
 Fluid specifications20



INITIAL STARTUP PROCEDURES	General21 Start-up procedure21
PRESSURE MEASUREMENTS	Required tools23 Port locations and gauge installation23
TROUBLESHOOTING	Overview26 Neutral difficult or impossible to find26 System operating hot26 Transmission operates normally in one direction only27 System will not operate in either direction.....27 Low motor output torque28 Improper motor output speed28 System noise or vibration28 System response is sluggish.....29
ADJUSTMENTS	Standard procedures, inspections, and adjustments30 Adjustments31 Charge pressure relief valve adjustment31 Multi-function valve pressure adjustment33 Engaging the bypass function.....35 Pressure override (POR) valve pressure adjustment (option for 180 frame size)36 Displacement limiter adjustment.....37 Standard manual displacement control (MDC) adjustment.....37 Non-linear manual displacement control (MDC).....38 MDC neutral start switch (NSS) adjustments39 Neutral start switch eccentric plug adjustment (condition i)41 NSS deadband adjustment (conditions ii & iii).....42 Checking switch continuity44 Hydraulic displacement control (HDC) and electric displacement control (EDC) adjustment45 Speed sensor adjustment.....46



MINOR REPAIR

Standard procedures	47
Shaft seal and shaft replacement	48
Multi-function valve cartridges	50
Multi-function valve cartridges - pre 1988.....	52
Pressure override valve (option for 180 frame size)	53
Charge pressure relief valve	54
Auxiliary pad	55
Charge pump	56
Adding an Auxiliary pad to a pump previously without one	58
Integral charge pressure filter replacement	59
Pump control cover plate	60
Displacement control orifices	61
Displacement control orifice check valve.....	61
Displacement control adapter plate (early production 130 pumps only)	61
Manual displacement control (MDC)	62
Solenoid override valve for MDC	63
Solenoid override valve for MDC with pressure released brake	64
Hydraulic and electric displacement controls	65
Pressure control pilot (PCP) for electric displacement control (EDC)	66
3-Position (FNR) electric control	67
Displacement control filter screens	68
Speed sensor.....	68

TORQUE CHART

Fastener size and torque chart	69
Plug size and torque chart	70
Fasteners and plugs.....	70



OVERVIEW

This manual includes information for the installation, maintenance, and minor repair of Series 90 axial piston closed circuit pumps. It includes a description of the unit and its individual components, troubleshooting information, and minor repair procedures.

Performing minor repairs requires you remove the unit from the vehicle/machine. Thoroughly clean the unit before beginning maintenance or repair activities. Since dirt and contamination are the greatest enemies of any type of hydraulic equipment, follow cleanliness requirements strictly. This is especially important when changing the system filter and when removing hoses or plumbing.

A worldwide network of Sauer-Danfoss Global Service Partners (GSPs) is available for major repairs. Sauer-Danfoss trains GSPs and certifies their facilities on a regular basis. You can locate your nearest ASC using the distributor locator at www.sauer-danfoss.com. Click on the *Sales and Service* link.

WARRANTY

Performing installation, maintenance, and minor repairs according to the procedures in this manual will not affect your warranty. Major repairs requiring the removal of a unit's rear or side cover voids the warranty unless done by a Sauer-Danfoss Authorized Service Center.

GENERAL INSTRUCTIONS

Follow these general procedures when repairing Series 90 variable displacement closed circuit pumps.

Remove the unit

Prior to performing major repairs, remove the unit from the vehicle/machine. Chock the wheels on the vehicle or lock the mechanism to inhibit movement. Be aware that hydraulic fluid may be under high pressure and/or hot. Inspect the outside of the pump and fittings for damage. Cap hoses after removal to prevent contamination.

Keep it clean

Cleanliness is a primary means of assuring satisfactory pump life, on either new or repaired units. Clean the outside of the pump thoroughly before disassembly. Take care to avoid contamination of the system ports. Cleaning parts by using a clean solvent wash and air drying is usually adequate.

As with any precision equipment, keep all parts free of foreign materials and chemicals. Protect all exposed sealing surfaces and open cavities from damage and foreign material. If left unattended, cover the pump with a protective layer of plastic.

Replace all O-rings and gaskets

Use new O-rings and gaskets during reassembly. Lightly lubricate all O-rings with clean petroleum jelly prior to assembly.

Secure the unit

For repair, place the unit in a stable position with the shaft pointing downward. It will be necessary to secure the pump while removing and torquing end covers, controls, and valves.



SAFETY PRECAUTIONS

Always consider safety precautions before beginning a service procedure. Protect yourself and others from injury. Take the following general precautions whenever servicing a hydraulic system.

Unintended machine movement

Warning

Unintended movement of the machine or mechanism may cause injury to the technician or bystanders. To protect against unintended movement, secure the machine or disable/disconnect the mechanism while servicing.

Flammable cleaning solvents

Warning

Some cleaning solvents are flammable. To avoid possible fire, do not use cleaning solvents in an area where a source of ignition may be present.

Fluid under pressure

Warning

Escaping hydraulic fluid under pressure can have sufficient force to penetrate your skin causing serious injury and/or infection. This fluid may also be hot enough to cause burns. Use caution when dealing with hydraulic fluid under pressure. Relieve pressure in the system before removing hoses, fittings, gauges, or components. Never use your hand or any other body part to check for leaks in a pressurized line. Seek medical attention immediately if you are cut by hydraulic fluid.





























Personal safety

Warning

Protect yourself from injury. Use proper safety equipment, including safety glasses, at all times.



SYMBOLS USED IN SAUER-DANFOSS LITERATURE

- | | |
|---|--|
|  WARNING may result in injury |  Tip, helpful suggestion |
|  CAUTION may result in damage to product or property |  Lubricate with clean hydraulic fluid |
|  Reusable part |  Apply grease/petroleum jelly |
|  Non-reusable part, use a new part |  Apply locking compound |
|  Non-removable item |  Inspect for wear or damage |
|  Option – either part may exist |  Clean area or part |
|  Superseded – parts are not interchangeable |  Be careful not to scratch or damage |
|  Measurement required |  Note correct orientation |
|  Flatness specification |  Mark orientation for reinstallation |
|  Parallelism specification |  Torque specification |
|  External hex head |  Press in – press fit |
|  Internal hex head |  Pull out with tool – press fit |
|  Torx head |  Cover splines with installation sleeve |
|  O-ring boss port |  Pressure measurement/gauge location or specification |

The symbols above appear in the illustrations and text of this manual. They are intended to communicate helpful information at the point where it is most useful to the reader. In most instances, the appearance of the symbol itself denotes its meaning. The legend above defines each symbol and explains its purpose.



DESIGN

Sauer-Danfoss Series 90 closed circuit piston pumps convert input torque into hydraulic power. The input shaft transmits rotational force to the cylinder block. Bearings support the input shaft at the front and rear of the pump. The shaft is splined into the cylinder block. A lip-seal at the front end of the pump prevents leakage where the shaft exits the pump housing. The spinning cylinder block contains nine reciprocating pistons. A ball joint at one end connects each piston to a brass slipper. Fixed-clearance hold-down brackets keep the slippers in contact with the swashplate. The reciprocating movement of the pistons occurs as the slippers slide against the inclined swashplate during rotation. The valve plate connects one half of the cylinder block to low pressure and the other half to high pressure. As each piston cycles in and out of its bore, fluid is drawn from the inlet and displaced to the outlet thereby imparting hydraulic power into the system. A small amount of fluid flows from the cylinder block/valve plate and slipper/swashplate interfaces for lubrication and cooling. Case drain ports return this fluid to the reservoir.

The angle of the swashplate controls the volume of fluid displaced into the system. The servo piston forces the swashplate into an inclined position. The pump control, acting on input from the operator, by modulating pressure balance across the servo piston, sets displacement in the system circuit.

Cross section

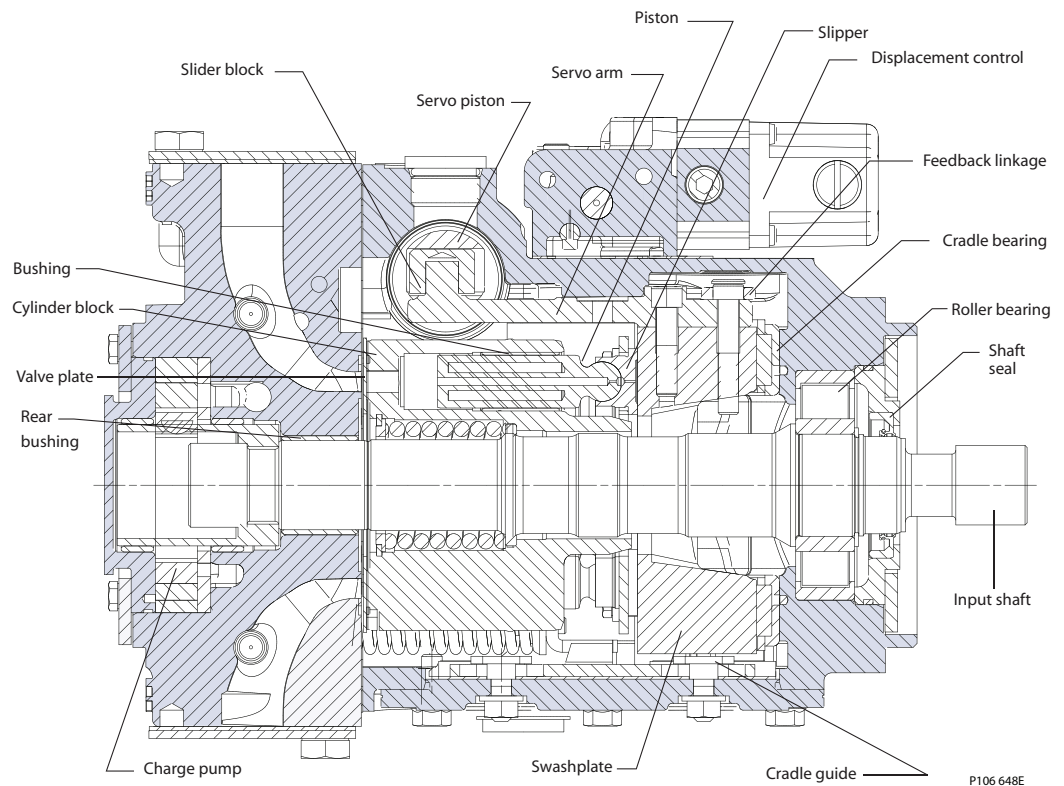

Series 90 Axial Piston Closed Circuit Pumps

Service Manual

Introduction



THE SYSTEM CIRCUIT

The basic closed circuit

Hydraulic lines connect the main ports of the pump to the main ports of the motor. Fluid flows in either direction from the pump to the motor then back to the pump in this closed circuit. Either of the hydraulic lines can be under high pressure. In pumping mode the position of the pump swashplate determines which line is high pressure as well as the direction of fluid flow.

Basic closed circuit diagram

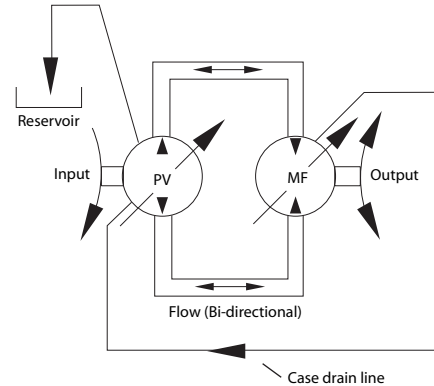

P104 120E

Case drain and heat exchanger

The pump and motor require case drain lines to remove hot fluid from the system. The topmost port drains the motor to ensure the case remains full of fluid. Fluid routes through the lower drain port on the pump and out the topmost port to the reservoir. A heat exchanger, with a bypass valve, cools the case drain fluid before it returns to the reservoir.

System circuit diagram

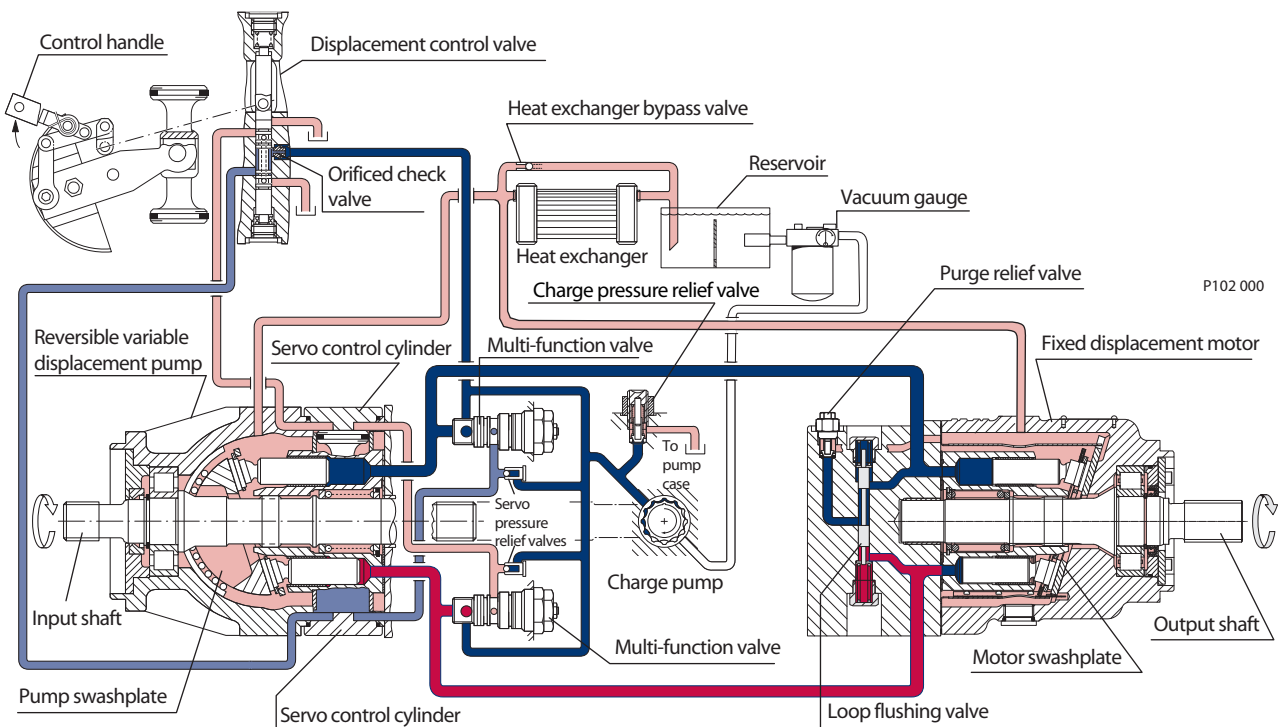

P102 000

Pump

Motor

■ Working loop (high pressure)
 ■ Working loop (low pressure)
 □ Suction line
 ■ Control fluid
 ■ Case drain fluid



**THE SYSTEM CIRCUIT
(continued)**

Pump schematic

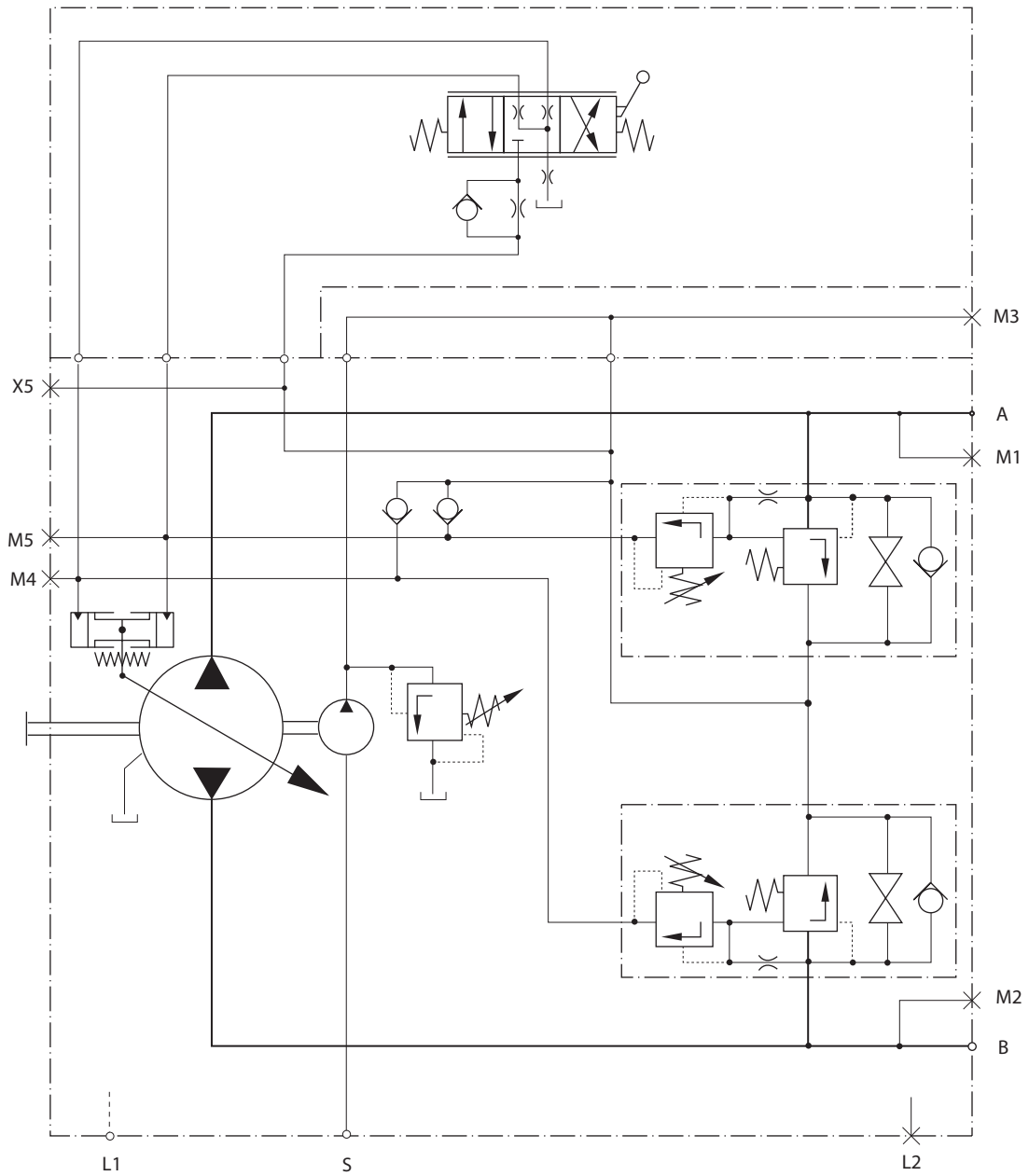

P104 126E



CHARGE PUMP

The charge pump is necessary to supply cool fluid to the system, to maintain positive pressure in the main system loop, to provide pressure to operate the control system, and to make up for internal leakage. Charge pressure must be at its specified pressure under all conditions to prevent damage to the transmission.

The charge pump is a fixed-displacement, gerotor type pump driven off the main pump shaft. The charge relief valve limits charge pressure.

Pump charge system

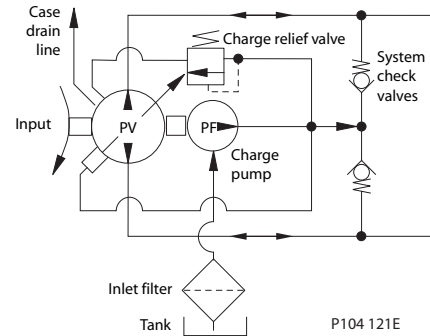

CHARGE RELIEF VALVE

The charge relief valve on the pump maintains charge pressure at a designated level. A direct-acting poppet valve relieves fluid when charge pressure reaches a certain level. This level is nominally set referencing case pressure at 1500 rpm. This nominal setting assumes the pump is in neutral (zero flow). In forward or reverse, charge pressure is lower. The pump model code specifies the charge relief valve setting.

Charge pressure relief valve

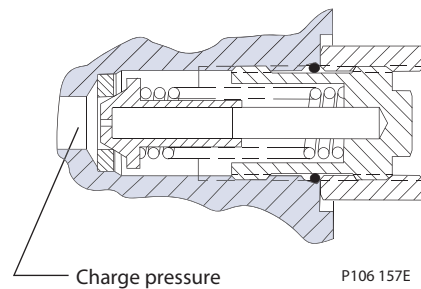

MULTI-FUNCTION VALVES

The multi-function valve incorporates the system check valve, the pressure limiter valve, the high pressure relief valve, and the bypass valve in a replaceable cartridge. These functions are described separately. There are two multi-function valve cartridges in each Series 90 pump to handle functions in either direction. See corresponding sections for adjustments and repairs.

Multi-function valve

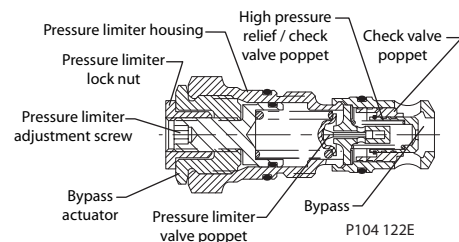

Some multi-function valves do not include a pressure limiter valve



PRESSURE LIMITER AND HIGH PRESSURE RELIEF VALVES

Series 90 pumps have a sequenced pressure limiting system and high pressure relief valves. When the system pressure reaches the preset, the pressure limiter system rapidly de-strokes the pump to limit system pressure. For unusually rapid load application, the high pressure relief valve immediately limits system pressure by cross-porting system flow. The pressure limiter valve acts as the pilot for the high pressure relief valve spool. The high pressure relief valve is sequenced to operate at approximately 35 bar (500 psi) above the level that initiates the pressure limiter valve.

Circuit diagram showing pressure control mechanism

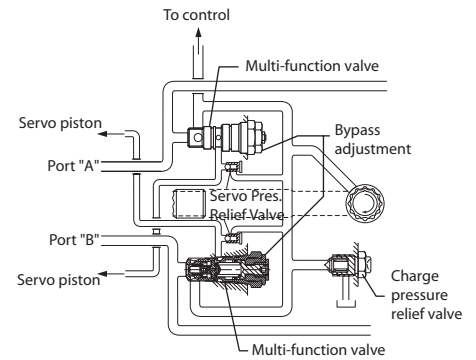

P104 123E

For some applications, such as dual path vehicles, the pressure limiter function may be defeated so that only the high pressure relief valve function remains.

SYSTEM CHECK VALVES

The system check valves allow pressurized flow from the charge pump to enter the low pressure side of the loop. This is needed as the pump generally loses system pressure due to lubrication/cooling flow and other factors. Since the pump operates in either direction, the system uses two check valves to direct the charge supply into the low pressure lines. The system check valves are part of the multi-function valve assembly.

BYPASS VALVES

You can operate the bypass valves to move the vehicle or mechanical function when the pump is not running. Manually resetting the valve position opens the valve. The bypass valves are built into the multi-function valves.

SPEED SENSORS

An optional speed sensor can provide unit speed information. The sensor reads a magnetic ring on the unit's cylinder block. See the corresponding section to locate, install, and adjust the speed sensor.

Series 90 Axial Piston Closed Circuit Pumps

Service Manual

Operation



FILTRATION OPTIONS

Series 90 pumps may have either suction or charge pressure filtration to filter the fluid entering the circuit.

Suction filtration – option S

The suction filter is in the circuit between the reservoir and the inlet to the charge pump, as shown below. The use of a filter contamination monitor is recommended.

Suction filtration

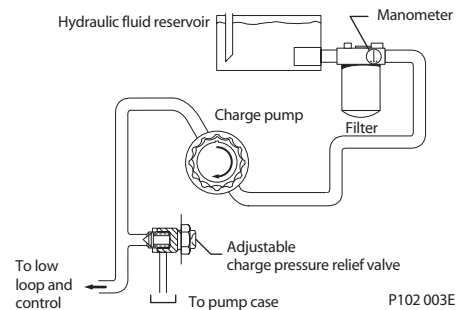

Charge pressure filtration – option R, T, P, and L

The pressure filter can be mounted on the pump or remotely for ease of servicing. You will typically find a 100-125 µm mesh screen, in the reservoir or the charge inlet. This system requires a filter capable of withstanding charge pressure (reference to atmosphere - add case pressure).

Charge pressure filtration

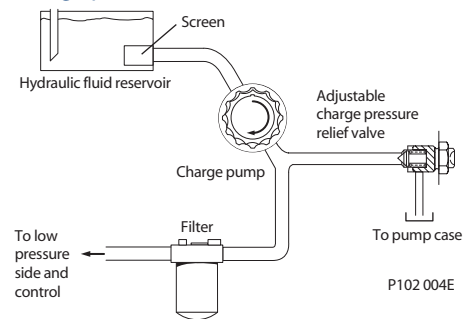

PRESSURE OVERRIDE (POR) – 180 FRAME SIZE ONLY

The Pressure OverRide valve (POR) modulates control pressure to maintain a pump displacement which produces a system pressure level less than or equal to the POR setting. For unusually rapid load application, the high pressure relief valve function of the multi-function valves is available to also limit the pressure level.

The pressure override consists of a three-way normally open valve which operates in series with the pump displacement control. Control supply pressure normally ports through the POR valve to the displacement control valve. If the system demands a pressure above the override setting, the POR valve overrides the control by reducing the pressure to the displacement control. As the control pressure reduces, the internal forces rotating the swashplate overcome the force of the servo pistons and decreases the pump's displacement.

POR-Valve (180 frame size only)

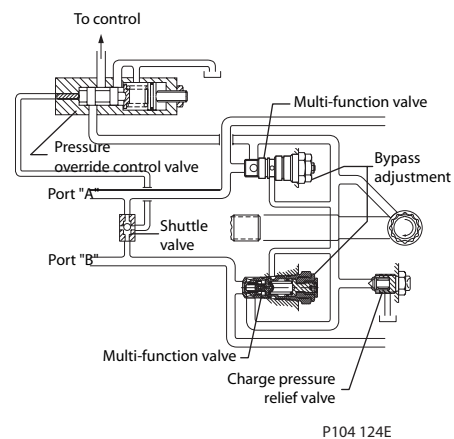



MANUAL DISPLACEMENT CONTROL (MDC)

The manual displacement control converts a mechanical input signal to a hydraulic signal using a spring-centered four-way servo valve. This valve ports hydraulic pressure to either side of a dual-acting servo piston. The servo piston rotates the cradle swashplate through an angular rotation of $\pm 17^\circ$, varying the pump's displacement from full in one direction to full in the opposite direction. The angular position of the pump swashplate is proportional to the rotation of the control input shaft.

NON-LINEAR MDC

The non-linear manual displacement control operates in the same manner except that it is designed so the change in the angular position of the pump swashplate progressively increases as the control input shaft is rotated toward its maximum displacement position.

SOLENOID OVERRIDE VALVE FOR MDC

A solenoid override valve option is available for the MDC. This safety feature returns the swashplate to zero displacement. It is available in normally open (activate to allow) or normally closed (activate to disallow) options..

NEUTRAL START SWITCH (NSS)

The neutral start switch is an optional feature available with the MDC. When connected properly with the vehicle's electrical system, the neutral start switch ensures that the prime mover can start only when the control is in neutral position.

HYDRAULIC DISPLACEMENT CONTROL (HDC)

The hydraulic displacement control uses a hydraulic input signal to operate a spring-centered four-way servo valve. This valve ports hydraulic pressure to either side of a dual-acting servo piston. The servo piston rotates the cradle swashplate through an angular rotation of $\pm 17^\circ$, thus varying the pump's displacement from full displacement in one direction to full displacement in the opposite direction. The angular position of the pump swashplate is proportional to input pressure.

ELECTRIC DISPLACEMENT CONTROL (EDC)

The electric displacement control uses a Pressure Control Pilot (PCP) valve to modulate pressure balance across the spring-centered four-way servo valve. The PCP valve converts a DC electrical input signal to a hydraulic signal. The servo valve ports hydraulic pressure to either side of a dual-acting servo piston. The servo piston rotates the swashplate through an angular rotation of $\pm 17^\circ$, varying the pump's displacement. The angular position of the swashplate is proportional to the EDC input.

AUTOMOTIVE CONTROL (FBA II B)

The automotive control allows the operator to drive a vehicle similar to an automobile with an automatic transmission. The automotive control includes a three-position electric control to provide direction control.

3-POSITION (FNR) ELECTRIC CONTROL

This control utilizes a 12 or 24 Vdc electrically operated spool valve to port pressure to either side of the pump servo piston. Energizing one of the solenoids causes the pump to go to its maximum displacement in the corresponding direction. All functions of the three-position (FNR) electric control are preset at the factory

Series 90 Axial Piston Closed Circuit Pumps Service Manual Operating parameters



OVERVIEW

This section defines the operating parameters and limitations for Series 90 pumps with regard to input speeds and pressures. For actual parameters, refer to the operating parameters for each displacement.

INPUT SPEED

Minimum speed is the lowest input speed recommended during engine idle condition. Operating below minimum speed limits the pump's ability to maintain adequate flow for lubrication and power transmission.

Continuous speed is the highest input speed recommended at full power condition. Operating at or below this speed should yield satisfactory product life.

Maximum speed is the highest operating speed permitted. Exceeding maximum speed reduces product life and can cause loss of hydrostatic power and braking capacity. Never exceed the maximum speed limit under any operating conditions.

When determining speed limits for a particular application see Sauer-Danfoss publication **BLN-9884** *Pressure and speed limits*.

Warning

Unintended vehicle or machine movement hazard

Exceeding maximum speed may cause a loss of hydrostatic drive line power and braking capacity. You must provide a braking system, redundant to the hydrostatic transmission, sufficient to stop and hold the vehicle or machine in the event of hydrostatic drive power loss.

SYSTEM PRESSURE

System pressure is the differential pressure between system ports A and B. It is the dominant operating variable affecting hydraulic unit life. High system pressure, which results from high load, reduces expected life. System pressure must remain at or below continuous pressure during normal operation to achieve expected life.

Continuous pressure is the average, regularly occurring operating pressure. Operating at or below this pressure should yield satisfactory product life.

Maximum pressure is the highest intermittent pressure allowed. Maximum machine load should never exceed this pressure. For all applications, the load should move below this pressure.

All pressure limits are differential pressures referenced to low loop (charge) pressure. Subtract low loop pressure from gauge readings to compute the differential.



CHARGE PRESSURE

An internal charge relief valve regulates charge pressure. The charge pump supplies the control with pressure to operate the swashplate and to maintain a minimum pressure in the low side of the transmission loop.

Minimum charge pressure is the lowest pressure allowed to maintain a safe working condition in the low side of the loop. Minimum control pressure requirements are a function of speed, pressure, and swashplate angle, and may be higher than the minimum charge pressure shown in the operating parameters table.

Maximum charge pressure is the highest charge pressure allowed by the charge relief adjustment, and provides normal component life. You can use elevated charge pressure as a secondary means to reduce the swashplate response time.

The charge pressure setting in the order code is the set pressure of the charge relief valve with the pump in neutral, operating at 1800 min^{-1} (rpm), and with a fluid viscosity of $32 \text{ mm}^2/\text{sec}$ (150 SUS). The charge pressure setting is referenced to case pressure. Charge pressure is the differential pressure above case pressure.

CHARGE INLET PRESSURE

At normal operating temperature charge inlet pressure must not fall below **rated charge inlet pressure**.

Minimum charge inlet pressure is only allowed at cold start conditions. In some applications it may be necessary to warm up the fluid by running the engine at limited speed until the system fluid temperature reaches an acceptable level.

CASE PRESSURE

Under normal operating conditions, do not exceed the **rated case pressure**. During cold start, maintain the case pressure below maximum intermittent case pressure.

ⓘ Caution

Possible component damage or leakage

Operation with case pressure in excess of stated limits may damage seals, gaskets, and/or housings, causing external leakage. Performance may also be affected since charge and system pressure are additive to case pressure.

Series 90 Axial Piston Closed Circuit Pumps Service Manual Operating parameters



TEMPERATURE AND VISCOSITY

Temperature

The high temperature limits apply at the hottest point in the transmission loop, which is normally the motor case drain. Maintain system temperature below the quoted **rated temperature**.

Never exceed the **maximum intermittent temperature**.

Cold oil will generally not affect the durability of the transmission components, but it may affect the ability of oil to flow and transmit power; therefore temperatures should remain 16 °C [30 °F] above the pour point of the hydraulic fluid.

The **minimum temperature** relates to the physical properties of component materials. Size heat exchangers to keep the fluid within these limits. Test heat exchangers to verify that these temperature limits are not exceeded.

Viscosity

For maximum efficiency and bearing life, ensure the fluid viscosity remains in the **recommended range**.

Minimum viscosity should be encountered only during brief occasions of maximum ambient temperature and severe duty cycle operation.

Maximum viscosity should be encountered only at cold start.



FLUID AND FILTER RECOMMENDATIONS

To ensure optimum pump life, perform regular maintenance of the fluid and filter. Contaminated fluid is the main cause of unit failure. Maintain fluid cleanliness when servicing.

Check the reservoir daily for proper fluid level, the presence of water, and rancid fluid odor. Fluid contaminated by water may appear cloudy or milky or free water may settle in the bottom of the reservoir. Rancid odor indicates the fluid has been exposed to excessive heat. Change the fluid immediately if these conditions occur. Correct the problem immediately.

Inspect vehicle for leaks daily.

Change the fluid and filter per the vehicle/machine manufacturer's recommendations or at the intervals shown in the table. Change fluid after first 500 hours.

Fluid and filter change interval

Reservoir type	Max oil change interval
Sealed	2000 hours
Breather	500 hours

⚠ Caution

High temperatures and pressures result in accelerated fluid aging. Change fluid more frequently if operating under extreme conditions.

Change the fluid more frequently if it becomes contaminated with foreign matter (dirt, water, grease, etc.) or if the fluid is subjected to temperature levels greater than the recommended maximum.

Dispose of used hydraulic fluid properly. Never reuse hydraulic fluid.

Change filters whenever the fluid is changed or when the filter indicator indicates a filter change. Replace all fluid lost during filter change.

For detailed filtration information, see Sauer-Danfoss publication **520L0463 *Fluids and Filtration***. For information on biodegradable fluids see Sauer-Danfoss publication **520L0465 *Biodegradable Hydraulic Fluids***.



OVERVIEW

Specifications and operating parameters for pumps appear here for reference.

FEATURES AND OPTIONS

Model	Series 90 Pumps
Mount	SAE B, SAE C and E (SAE J 744)
Pump type	Axial piston type
Rotation	Bidirectional
Installation position	Discretionary: Housing must always be filled with hydraulic fluid. Do not install with control on bottom.
Input shafts	Splined
Control options	MDC (with options), EDC, HDC, FNR

OPERATING PARAMETERS

Parameter		Unit	Pressure
System pressure	Rated	bar [psi]	420 [6000]
	Maximum		480 [7000]
	Minimum low loop		10 [150]
Charge pressure	Minimum	bar [psi]	10 [150]
	Maximum		35 [508]
Charge inlet pressure	Rated	bar (absolute)	0.7 [9]
	Minimum (cold start)	[in Hg vacuum]	0.2 [24]
Case pressure	Rated	bar [psi]	3.0 [40]
	Maximum		5.0 [75]

Parameter	Unit	Frame size						
		042	055	075	100	130	180	250
Displacement (maximum)	cm³ [in ³]	42 [2.56]	55 [3.35]	75 [4.57]	100 [6.10]	130 [7.93]	180 [10.98]	250 [15.25]
Minimum speed	min⁻¹ (rpm)	500	500	500	500	500	500	500
Rated speed	min⁻¹ (rpm)	4200	3900	3600	3300	3100	2600	2300
Maximum speed	min⁻¹ (rpm)	4600	4250	3950	3650	3400	2850	2500
Maximum attainable speed at maximum displacement	min⁻¹ (rpm)	5000	4700	4300	4000	3700	3150	3750
Theoretical torque at maximum displacement	N·m/bar [lbf·in/1000 psi]	0.67 [380]	0.88 [530]	1.19 [730]	1.59 [870]	2.07 [1260]	2.87 [1750]	3.97 [2433]
Weight (base unit only)	kg [lb]	34 [75]	40 [88]	49 [108]	68 [150]	88 [195]	136 [300]	154 [340]

FLUID SPECIFICATIONS

Ratings and data are based on operation with premium petroleum-based hydraulic fluids containing oxidation and foam inhibitors.

Parameter	Unit	Minimum	Continuous	Maximum
Viscosity	mm ² /sec (cSt) [SUS]	7 [47]	12-60 [66-278]	1600 [7500]
Temperature	°C [°F]	-40 [-40]	104 [220]	115 [240]
Cleanliness		ISO 4406 Class 22/18/13 or better		
Filtration efficiency	suction filtration	$\beta_{35-44}=75$ ($\beta_{10} \geq 2$)		
	charge filtration	$\beta_{15-20}=75$ ($\beta_{10} \geq 10$)		



GENERAL

Follow this procedure when starting-up a new pump installation or when restarting an installation in which the pump was removed.

Warning

Unintended movement of the machine or mechanism may cause injury to the technician or bystanders. To protect against unintended movement, secure the machine or disable/disconnect the mechanism while servicing.

Prior to installing the pump, inspect for shipping damage.

START-UP PROCEDURE

1. Ensure that the hydraulic fluid and system components (reservoir, hoses, valves, fittings, and heat exchanger) are clean and free of contamination.
2. Install new system filter element(s) if necessary. Check that inlet line fittings are properly tightened and there are no air leaks.
3. Install the pump. Install a 50 bar [1000 psi] gauge in the charge pressure gauge port M3.
4. Fill the housing by adding filtered fluid in the upper case drain port. Open the case plug in the top of the control to assist with air bleed.
5. Fill the reservoir with hydraulic fluid of the recommended type and viscosity. Use a 10-micron filler filter. Fill inlet line from reservoir to pump.
6. Disconnect the pump control input signal.

After start-up the fluid level in the reservoir may drop due to filling of the system components. Check the level in the reservoir to maintain a full fluid level throughout the start-up procedure.

Caution

Damage to hydraulic components may occur from failure to maintain fluid supply.

7. Use a common method to disable the engine to prevent the engine from starting. Crank the starter for several seconds. Do not to exceed the engine manufacturer's recommendation. Wait 30 seconds and then crank the engine a second time. This operation helps remove air from the system lines. Refill the reservoir to recommended full fluid level.

Series 90 Axial Piston Closed Circuit Pumps Service Manual Initial start-up procedure



START-UP PROCEDURE (continued)

8. When charge pressure reaches 3.5 bar [50 psi], enable and start engine. Let the engine run for a minimum of 30 seconds at low idle to allow the air to work itself out of the system. Check for leaks at all line connections and listen for cavitation. Check for proper fluid level in reservoir.

⚠ Caution

Air entrapment in fluid under high pressure may damage hydraulic components.

⚠ Caution

Do not run at maximum pressure until system is free of air and fluid has been thoroughly filtered.

9. When adequate charge pressure is established (as shown in model code), increase engine speed to normal operating rpm to further purge residual air from the system.
10. Shut off the engine. Connect the pump control signal. Start the engine, checking to be certain the pump remains in neutral. Run the engine at normal operating speed and carefully check for forward and reverse control operation.
11. Continue to cycle between forward and reverse for at least five minutes to bleed all air and flush system contaminants out of loop.

Normal charge pressure fluctuation may occur during forward and reverse operation.

12. Check that the reservoir is full. Remove charge pressure gauge. The pump is now ready for operation.



REQUIRED TOOLS

You can perform the service procedures described in this manual using common mechanic’s tools. Special tools, if required are shown. Use calibrated pressure gauges to ensure accuracy. Use snubbers to protect pressure gauges.

PORT LOCATIONS AND GAUGE INSTALLATION

The following sections list the ports for each type of hydraulic unit. The fitting size and recommended pressure gauge are also specified.

The following table and drawings show the port locations and gauge sizes needed.

Port information

Port identifier	Pressure obtained	Gauge size	Port size	
M1, M2	System pressure	1000 bar [10 000 psi]	9/16-18	
M3 (M6)	Charge pressure	50 bar [1000 psi]	9/16-18	
M4, M5	Servo pressure	50 bar [1000 psi]	9/16-18	
L1, L2	Case pressure	10 bar [100 psi]	030-042	7/8-14
			055-100	1-1/16-12
			130	1-5/16-12
			180-250	1-5/8-12
X1, X2	HDC/EDC control pressure	50 bar [1000 psi]	7/16-20 or 9/16-18	
X3	External control pressure	50 bar [1000 psi]	9/16-18	
S	Charge pump inlet	Vacuum gauge, Tee into inlet line	030-042	1-1/16-12
			055-075	1-5/16-12
			100-180	1-5/8-12
			250	1-1/2 SAE-split flange



**PORT LOCATIONS AND
 GAUGE INSTALLATION
 (continued)**

Pump with side port end cap and manual displacement control

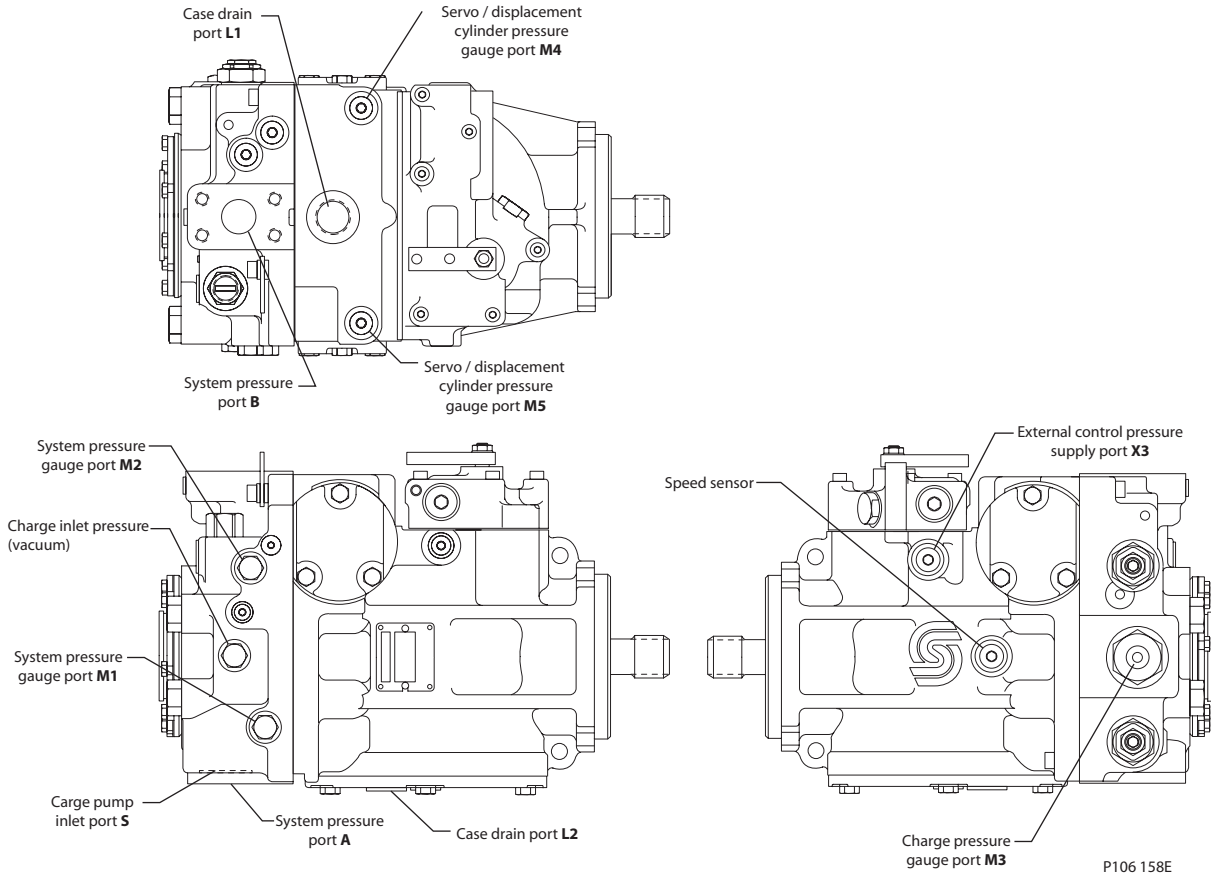

P106 158E



**PORT LOCATIONS AND
 GAUGE INSTALLATION
 (continued)**

Pump with twin port end cap and manual displacement control

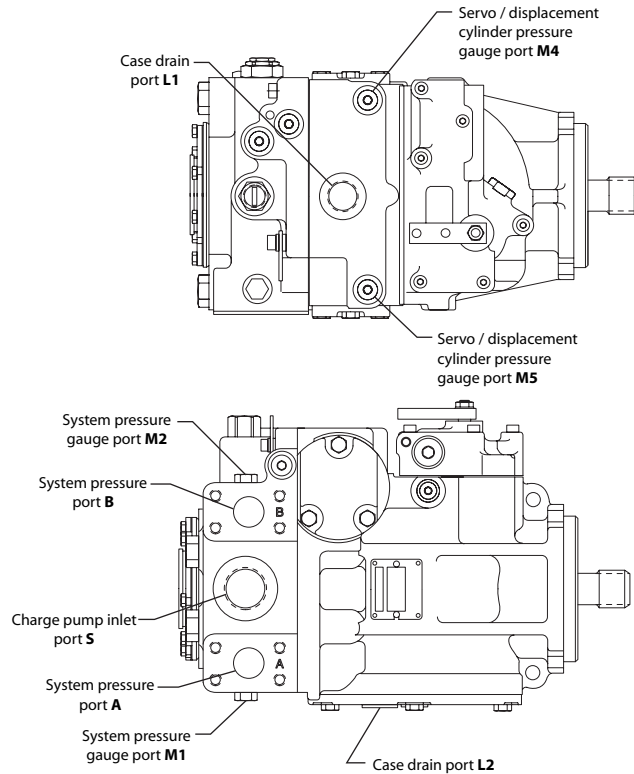

P106 160E

Pump with side port end cap and remote pressure filtration

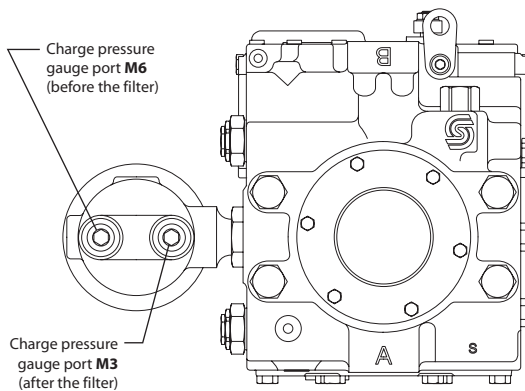

Pump with side port end cap and integral pressure filtration

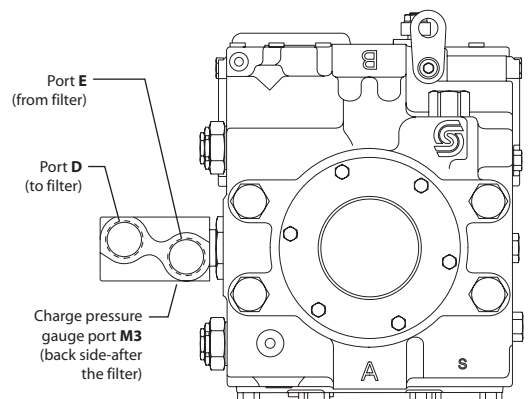

P106 163E

Series 90 Axial Piston Closed Circuit Pumps

Service Manual

Troubleshooting



OVERVIEW

This section provides general steps to follow if certain undesirable system conditions occur. Follow the steps in a section until you solve the problem. Some of the items are system specific. For areas covered in this manual, we reference the section. Always observe the safety precautions listed in the *Introduction* section (page 6) and those relating to your specific equipment.

NEUTRAL DIFFICULT OR IMPOSSIBLE TO FIND

Item	Description	Action
Input to pump control	Input to control module is operating improperly.	Check control input and repair or replace as necessary.
Pump displacement control	Control linages are not secure, control orifices are blocked.	Adjust, repair, or replace control module as necessary.
Multifunction valve	Multifunction valve is leaking.	Swap multifunction valves. If system changes direction, replace defective valve.

SYSTEM OPERATING HOT

Item	Description	Action
Oil level in reservoir	Insufficient hydraulic fluid will not meet cooling demands of system.	Fill reservoir to proper level.
Heat exchanger	Heat exchanger is not sufficiently cooling the system.	Check air flow and input air temperature for heat exchanger. Clean, repair, or replace heat exchanger.
Charge pressure	Low charge pressure will overwork system.	Measure charge pressure. Inspect and adjust or replace charge relief valve, or repair leaky charge pump.
Charge pump inlet vacuum	High inlet vacuum will overwork system. A dirty filter will increase the inlet vacuum. Inadequate line size will restrict flow.	Check charge inlet vacuum. If high, inspect inlet filter and replace as necessary. Check for adequate line size, length or other restrictions.
System relief pressure settings	If the system relief settings are too low, the relief valves will be overworked.	Verify settings of pressure limiters and high pressure relief valves and adjust or replace multi-function valves as necessary.
For internal leakage in motor	Leakage will reduce low side system pressure and overwork the system.	Monitor motor case flow without loop flushing in the circuit (use defeat spool). If flow is excessive, replace motor.
System pressure	High system pressure will overheat system.	Measure system pressure. If pressure is high, reduce loads.



**TRANSMISSION
 OPERATES NORMALLY IN
 ONE DIRECTION ONLY**

Item	Description	Action
Input to pump control	Input to control module is operating improperly.	Check control input and repair or replace as necessary.
Pump displacement control	Control linkages are not secure, control orifices are blocked.	Repair or replace control module as necessary.
System pressure limiters, high pressure relief valves, or system check valves	Interchanging the multi-function valves will show if the problem is related to the valve functions contained in the multi-function valves.	Interchange multi-function valves. If the problem changes direction, repair or replace the valve on the side that does not operate.
Charge pressure	If charge pressure decays in one direction, the loop flushing valve may be sticking in one direction.	Measure charge pressure in forward and reverse. If pressure decays in one direction, inspect and repair the motor loop flushing valve.

**SYSTEM WILL NOT
 OPERATE IN EITHER
 DIRECTION**

Item	Description	Action
Oil level in reservoir	Insufficient hydraulic fluid to supply system loop	Fill reservoir to proper level.
Input to pump control	Input to control module is operating improperly	Check control input and repair replace as necessary.
Pump displacement control	Control linkage is not secure, control orifices are blocked, etc.	Repair or replace control module as necessary.
Bypass valve(s) open	If bypass valve(s) are open, the system loop will be depressurized.	Close bypass valves. Replace multi-function valve if defective.
Charge pressure with pump in neutral	Low charge pressure is insufficient to recharge system loop.	Measure charge pressure with the pump in neutral. If pressure is low, go to <i>Pump charge relief valve</i> ; otherwise continue with <i>Charge pressure with pump in stroke</i> .
Charge pressure with pump in stroke	Low charge pressure with the pump in stroke indicates a motor charge relief valve or system pressure relief valve may be improperly set.	Measure charge pressure with pump in stroke. If pressure is low, adjust or replace motor charge relief valve, otherwise go to <i>Charge pumps</i> .
Pump charge relief valve	A pump charge relief valve that is leaky or set too low will depressurize the system.	Adjust or replace pump charge relief valve as necessary.
Charge pump inlet filter	A clogged filter will under supply system loop.	Inspect filter and replace if necessary.
Charge pumps	A malfunctioning charge pump will provide insufficient charge flow.	Repair or replace the charge pump.
Pump displacement control	Control linkages are not secure, control orifices are blocked.	Repair or replace control module as necessary.
System pressure	Low system pressure will not provide power necessary to move load.	Measure system pressure. Continue to next step.
System multi-function valves	Defective multi-function valves will cause system to pressure to be low.	Repair or replace multi-function valve(s).

Series 90 Axial Piston Closed Circuit Pumps

Service Manual

Troubleshooting



LOW MOTOR OUTPUT TORQUE

Item	Description	Action
System pressure at motor	Low system pressure at the motor will reduce torque	Measure system pressure at motor. If pressure limiter setting is low, increase setting.
Variable motor stuck at minimum displacement	Minimum motor displacement yields low output torque.	Check control supply pressure or repair displacement control. Check motor control orifices.
Internal leakage	Internal leakage will reduce system pressure.	Check for leaking O-rings, gaskets and other fittings. Repair unit as required, or replace leaking unit.

IMPROPER MOTOR OUTPUT SPEED

Item	Description	Action
Oil level in reservoir	Insufficient hydraulic fluid will reduce motor speed.	Fill oil to proper level.
Pump output flow	Incorrect outflow will affect output speed. Incorrect output flow indicates the swashplate is out of position.	Measure pump output and check for proper pump speed. Ensure the pump is in full stroke.
Variable motor displacement control	If variable motor displacement control is not functioning correctly, variable motor swashplate may be in wrong position.	See if variable motor displacement control is responding. If not, repair or replace control.
Internal leakage	Internal leakage will reduce system pressure.	Check for leaking O-rings, gaskets, and other fittings. Repair unit as required, or replace leaky unit.

SYSTEM NOISE OR VIBRATION

Item	Description	Action
Oil in reservoir	Insufficient hydraulic fluid will lead to cavitation.	Fill reservoir to proper level.
Air in system	Air bubbles will lead to cavitation.	Look for foam in reservoir. Check for leaks on inlet side system loop and repair. Afterwards, let reservoir settle until foam dissipates. Run system at low speed to move system fluid to reservoir. Repeat.
Pump inlet vacuum	High inlet vacuum causes noise. A dirty filter will increase the inlet vacuum.	Inspect and replace filter as necessary. Check for proper suction line size.
Shaft couplings	A loose shaft coupling will cause excessive noise.	Replace loose shaft coupling or replace pump or motor.
Shaft alignment	Misaligned shafts cause noise.	Align shafts.



SYSTEM RESPONSE IS SLUGGISH

Item	Description	Action
Oil level in reservoir	Insufficient hydraulic fluid causes sluggish response.	Fill reservoir to proper level.
Multi-function valves pressure settings	Incorrect pressure settings affects system reaction time.	Adjust or replace multi-function valves.
Pump inlet vacuum	High pump inlet vacuum reduces system pressure.	Measure charge inlet vacuum. If high, replace inlet filter.
Prime mover speed	Low engine speed reduces system performance.	Adjust engine speed.
Charge and control pressures	Incorrect charge or control pressures affects system performance.	Measure charge and control pressures and correct if necessary.
System internal leakage	Internal leakage reduces system pressure.	Check for leakage in O-rings, gaskets, and other fittings.

Series 90 Axial Piston Closed Circuit Pumps Service Manual Adjustments



STANDARD PROCEDURES, INSPECTIONS, AND ADJUSTMENTS

Before working on the pump, clean the outside of the pump.

ⓘ Caution

Contamination can damage internal components and void your warranty. Take precautions to ensure system cleanliness when removing and reinstalling system lines.

1. With the prime mover off, thoroughly clean the outside of the pump.
2. If removing the pump, tag each hydraulic line connected to the pump. If hydraulic lines are disconnected, plug each open port with a clean plug, to ensure that dirt and contamination do not get into the pump.
3. Ensure the surrounding areas are clean and free of contaminants.
4. Inspect the system for contamination.
5. Visually inspect the hydraulic fluid for signs of system contamination, fluid discoloration, foam in the fluid, sludge, or small metal particles.
6. If there are signs of contamination in the hydraulic fluid, replace all filters, drain and flush the hydraulic system, and fill with the correct filtered hydraulic fluid.
7. Flush the lines before replacing the hydraulic fluid.



ADJUSTMENTS

This section offers instruction on inspection and adjustment of pump components. Read through the entire related section before beginning a service activity. Refer to *Pressure measurements*, pages 23, 24 and 25, for location of gauge ports and suggested gauge sizes.

CHARGE PRESSURE RELIEF VALVE ADJUSTMENT

The following procedure explains how to check and adjust the charge pressure relief valve.

Warning

The following procedure may require the vehicle/machine to be disabled (wheels raised off the ground, work function disconnected, etc.) in order to prevent injury to the technician and bystanders. Take necessary safety precautions before moving the vehicle/machine.

1. Install a 50 bar [1000 psi] pressure gauge in the pump charge pressure gauge port (M3). Install a 10 bar [100 psi] gauge to measure case pressure (tee into L1 or L2 or use servo gauge port M4 or M5). Operate the system with the pump in neutral (zero displacement) when measuring pump charge pressure.
2. The table shows the acceptable pump charge pressure range for some charge relief valve settings. These pressures assume 1500 min⁻¹ (rpm) and a reservoir temperature of 50°C [120°F], and are referenced to case pressure.

Charge pressure relief valve

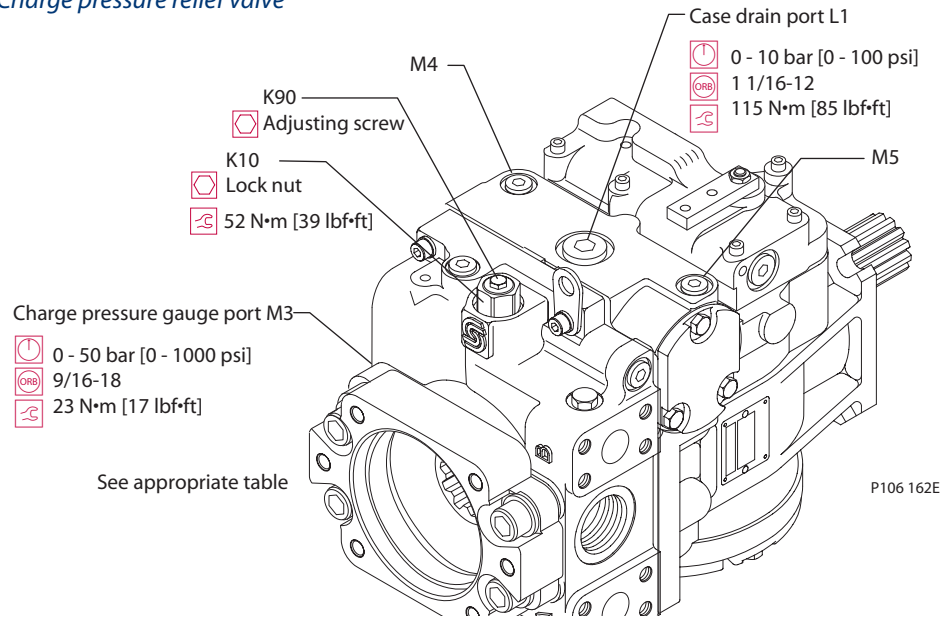

Listed pressures assume a pump speed of 1500 min⁻¹ (rpm). At higher pump input speeds (with higher charge flows) the charge pressure will rise over the rated setting.

Charge pressure ranges

Model code	Measured charge pressure*
20	18.1 – 21.7 bar [262 – 315 psi]
24	22.0 – 26.9 bar [319 – 390 psi]
28	25.8 – 30.7 bar [37.4 – 44.5 psi]

* This is the actual charge pressure port gauge reading minus the case pressure port gauge reading.



CHARGE PRESSURE RELIEF VALVE ADJUSTMENT (continued)

3. Earlier production Series 90 pumps have a shim adjustable charge pressure relief valve. Shim kits are available from Sauer-Danfoss. Remove the plug using a 1 in hex wrench and exchange shims behind the spring to adjust charge pressure. Torque plug to 68 N•m [50 lbf•ft].
4. Later production Series 90 pumps have an external screw-adjustable charge pressure relief valve. Loosen locknut (K10) and turn the adjusting screw (K90) using a screwdriver or 1/2 in. hex wrench to adjust charge pressure setting.

Lock nut wrench size

Frame size	Wrench size
030 – 100	1-1/16 inch
130 – 250	1-5/8 inch

5. Clockwise rotation of the plug increases the setting and counterclockwise rotation decreases the setting (at a rate of approximately 3.9 bar [50 psi] per turn). Torque lock nut to 52 N•m [39 lbf•ft].
6. Once you achieve the desired charge pressure setting, remove the gauges and plug the ports.

**MULTI-FUNCTION VALVE
 PRESSURE ADJUSTMENT**

You accomplish adjustment of the pressure limiter setting and the high pressure relief valve (HPRV) setting simultaneously. The HPRV setting is automatically set approximately 35 bar [500 psi] above the pressure limiter setting.

⚠ Warning
 Take necessary precautions that the motor shaft remains stationary during the adjustment procedure.

Lock the motor output shaft by locking the vehicle's brakes or rigidly fixing the work function so it cannot rotate or cap the system ports. ⚠

Multi-function valve adjustment

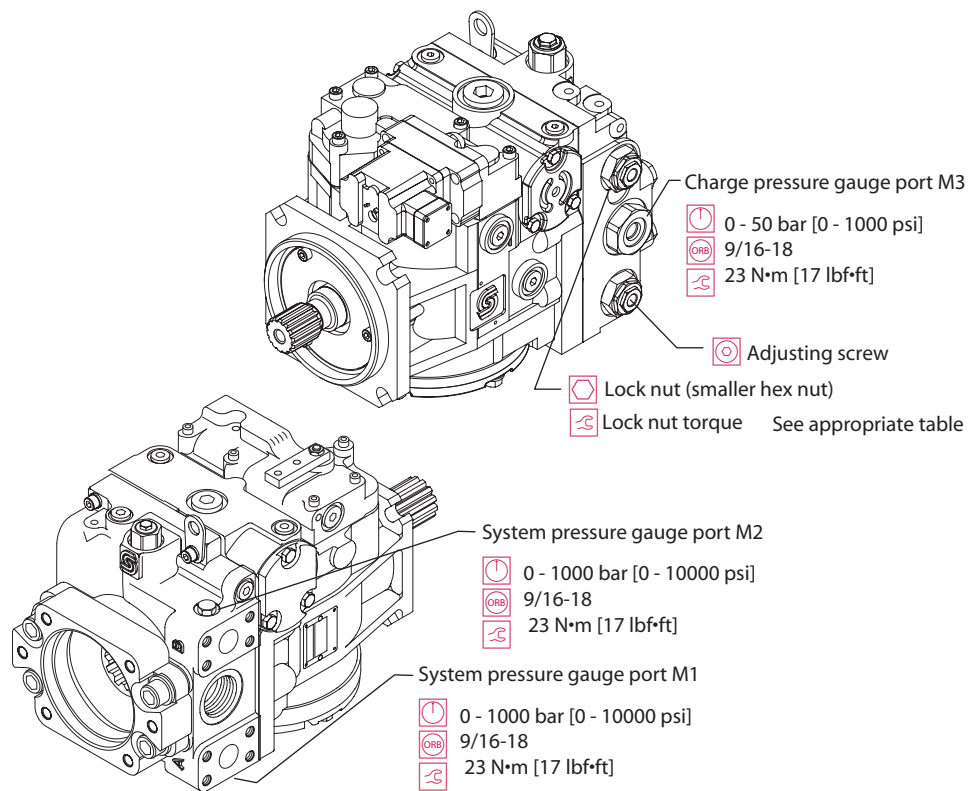

P106 168E

1. Install two 1000 bar (or 10 000 psi) pressure gauges in the high pressure gauge ports (M1 and M2). Install a 50 bar (or 1000 psi) pressure gauge in the pump charge pressure gauge port (M3).
2. Start the prime mover and operate at normal speed.
3. Loosen locking nut.
4. Insert an internal hex wrench into the pressure adjusting screw.

A plastic dust plug is installed in the adjusting screw.

Series 90 Axial Piston Closed Circuit Pumps Service Manual Adjustments



MULTI-FUNCTION VALVE PRESSURE ADJUSTMENT (continued)

- The model code shows the factory preset pressure limiter setting. It is referenced to charge pressure, so the pressure limiter setting is the difference between the high and low pressure sides of the system loop. Activate or move the control input so that pressure increases in the high pressure side of the closed circuit to the pressure limiter pressure setting. The pressure limiter setting is reached when the pressure stops increasing and remains steady at a given pressure level (as shown on the gauges).
- Return the pump to its neutral (zero flow) position and adjust the pressure limiter setting by rotating the pressure adjusting screw with an internal hex wrench.

Clockwise rotation of the pressure adjustment screw increases the pressure setting, and counterclockwise rotation decreases the pressure setting. Each complete rotation of the pressure adjusting screw changes the pressure as shown in the following table.

Pressure limiter adjustment data

Frame size	Lock nut wrench size and torque	Adjusting screw size	Approximate pressure change per revolution of adjusting screw
early 042-100	10 mm 3 N·m [26 lbf·in]	3 mm	80 bar [1157 psi]
030-100	19 mm 20 N·m [15 lbf·ft]	5 mm	90 bar [1300 psi]
early 130	13 mm 20 N·m [15 lbf·ft]	4 mm	80 bar [1157 psi]
130-250	24 mm 40 N·m [30 lbf·ft]	8 mm	80 bar [1157 psi]

- To verify the actual pressure setting, actuate or move the control input so that the pump again develops pressure in the high pressure circuit to the newly adjusted pressure limiter pressure setting; then read the high pressure gauge. Allow the pump to return to its neutral position. The pressure in the high pressure circuit should return to the charge pressure setting.
- While holding the pressure adjusting screw stationary, tighten the pressure adjusting screw lock nut. Torque as shown in the table.

Do not overtorque.

- Shut down the prime mover, remove the gauges and install the gauge port plugs. Replace the plastic dust plugs (if used).

Use the same procedure for setting the pressure limit of the other multi-function valve. Move or activate the control input signal in the opposite direction so that high pressure develops in the opposite side of the closed circuit.

Series 90 Axial Piston Closed Circuit Pumps

Service Manual

Adjustments



ENGAGING THE BYPASS FUNCTION

⚠ Caution

Damage to the pump and motor can result from rotating these components without charge flow for lubrication. Bypass valves are intended for moving a machine or vehicle for very short distances at very slow speeds. They are not tow valves.

The multi-function valve cartridges perform the bypass function. Shut down the prime mover when engaging the bypass function. Open both the bypass valves to engage the bypass function.

1. Loosen the bypass actuator three turns. Refer to table for wrench size.

Do not rotate more than 3-1/2 revolutions, as additional rotation will permit external leakage.

2. For units with an MDC-type control, prior to moving the vehicle or otherwise causing the motor shaft to turn, move the control handle of the manual displacement control on the pump to the maximum full forward position. Hold the handle in this position during bypass valve operation.
3. To close the bypass valve, tighten the bypass actuator. See table provided for proper torque.

Bypass actuator wrench size

Frame size	Wrench size
newer 030 – 100	1-1/16 inch
130 – 250	1-3/8 inch

Multi-Function Valve with Bypass Function Engaged

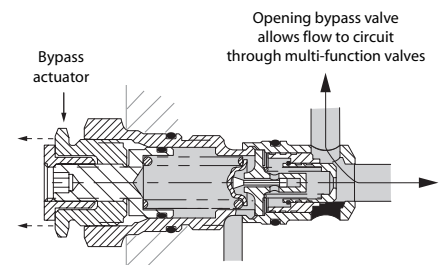

P104 144E

Bypass actuator torque

Frame size	Torque
newer 030 – 100	41 N•m [30 lbf•ft]
130 – 250	100 N•m [75 lbf•ft]

Series 90 Axial Piston Closed Circuit Pumps Service Manual Adjustments



PRESSURE OVERRIDE (POR) VALVE PRESSURE ADJUSTMENT (OPTION FOR 180 FRAME SIZE)

⚠ Warning

Unintended movement of the machine or mechanism may cause injury to the technician or bystanders. To protect against unintended movement, secure the machine or disable/disconnect the mechanism while servicing.

Pressure override valve operation is explained in the *Operation section* (page 14).

1. Install two 1000 bar [10 000 psi] pressure gauges in the high pressure gauge ports (M1 and M2). Install a 50 bar [1000 psi] pressure gauge in the pump charge pressure gauge port (M3).
2. Start the prime mover and operate at normal speed.
3. With the pump operating at approximately 20% displacement, load the work function and note the pressure as the POR valve operates (pump displacement reduces to zero).
4. Adjust the pressure override setting by loosening the lock nut with a 9/16 inch hex wrench and turning the adjustment screw with a 3/16 inch internal hex wrench. Set the POR setting to at least 50 bar [750 psi] below the high pressure relief valve setting of the multi-function valves.
5. Torque the lock nut to 43 N•m [32 lbf•ft].
6. Shut down the prime mover and remove the gauges and install the gauge port plugs.

Pressure override valve for 180 frame size

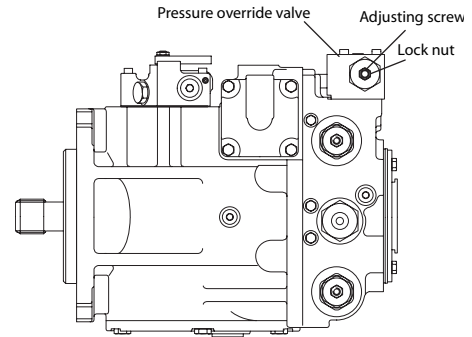

P104 145E



DISPLACEMENT LIMITER ADJUSTMENT

Caution

Take care in adjusting displacement limiters to avoid undesirable flow or speed conditions. Re-torque lock nut (F212) after every adjustment to prevent an unexpected change in operating conditions and to prevent external leakage during unit operation.

You can limit the maximum displacement in either direction.

1. Loosen the lock nut (F212) while holding the adjusting screw (F213) steady.
2. Rotate the adjusting screw some amount (using information in the following table). Rotating the adjusting screw clockwise decreases the maximum displacement of the pump while rotating the adjusting screw counterclockwise increases the maximum displacement.
3. One turn of the adjusting screw changes the maximum displacement as shown in table below
3. After establishing the desired maximum displacement setting, torque the lock nut to the torque shown in table below.

Displacement limiter adjustment

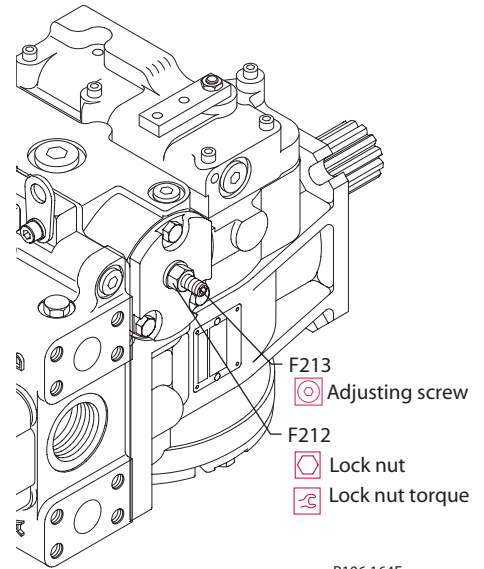

P106 164E

Frame size	Lock nut wrench size and torque	Adjusting screw size	Approximate displacement change per revolution of adjusting screw
030	13 mm 24 N•m [18 lbf•ft]	4 mm	2.8 cm ³ /(rev) [0.17 in ³ /rev]
042	13 mm 24 N•m [18 lbf•ft]	4 mm	3.5 cm ³ /(rev) [0.21 in ³ /rev]
055	13 mm 24 N•m [18 lbf•ft]	4 mm	4.2 cm ³ /rev [0.26 in ³ /rev]
075	13 mm 24 N•m [18 lbf•ft]	4 mm	5.1 cm ³ /rev [0.31 in ³ /rev]
100	13 mm 24 N•m [18 lbf•ft]	4 mm	6.2 cm ³ /rev [0.38 in ³ /rev]
130	17 mm 48 N•m [35 lbf•ft]	5 mm	8.8 cm ³ /rev [0.53 in ³ /rev]
180	19 mm 125 N•m [92 lbf•ft]	6 mm	12.5 cm ³ /rev [0.76 in ³ /rev]
250	19 mm 125 N•m [92 lbf•ft]	6 mm	17.3 cm ³ /rev [1.06 in ³ /rev]

STANDARD MANUAL DISPLACEMENT CONTROL (MDC) ADJUSTMENT

There are no adjustable elements in the manual displacement control. Centering springs and washers on each end of the control spool hold it in its neutral position. Since there is no centering spring on the control input shaft, the shaft automatically assumes the appropriate position when the control is installed on the pump.

Series 90 Axial Piston Closed Circuit Pumps Service Manual Adjustments



NON-LINEAR MANUAL DISPLACEMENT CONTROL (MDC)

A centering spring, located on the control input shaft, locates the control shaft in its neutral position. A bias spring on the control spool maintains a force on the spool and the control linkage to eliminate free-play in the linkage.

Neutral adjustment is the only adjustment that can be made on the nonlinear manual displacement control. All other functions are preset at the factory. Perform neutral adjustment on a test stand or on the vehicle/machine with the prime mover operating.

⚠ Warning

Unintended movement of the machine or mechanism may cause injury to the technician or bystanders. To protect against unintended movement, secure the machine or disable/disconnect the mechanism while servicing.

MDC neutral adjustment

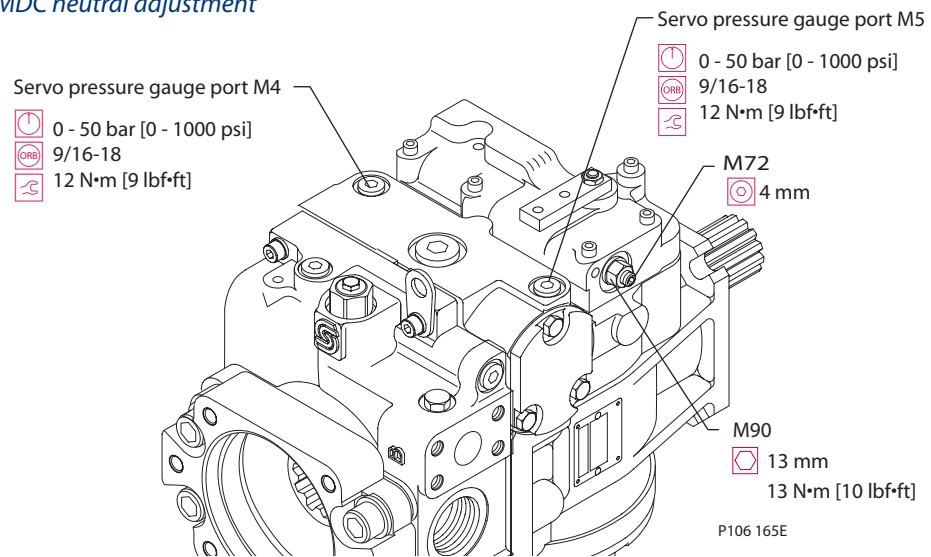

1. Install a 50 bar [1000 psi] gauge in each of the two servo cylinder gauge ports (M4 and M5). Disconnect the external control linkage from the control handle and make certain the control shaft is in its neutral position. Start the prime mover and operate at normal speed.
2. Loosen the lock nut (M90) on the neutral adjusting screw (M72) with a 13 mm hex wrench.
3. Using a 4 mm internal hex wrench, rotate the neutral adjusting screw clockwise until the pressure increases on one of the pressure gauges. Note the angular position of the wrench. Then rotate the adjusting screw counterclockwise until the pressure increases by an equal amount on the other gauge. Note the angular position of the wrench.
4. Rotate the adjusting screw clockwise half the distance between the locations noted above. The gauges should read the same pressure, indicating that the control is in its neutral position.



**NON-LINEAR MANUAL
 DISPLACEMENT
 CONTROL (MDC)
 (continued)**

5. Hold the adjusting screw stationary and tighten the lock nut to 13.5 N•m [10 lbf•ft]. Do not overtorque the nut.
6. Once the neutral position is set, stop the prime mover, remove the gauges, and install the gauge port plugs. Reconnect the external control linkage.

**MDC NEUTRAL
 START SWITCH (NSS)
 ADJUSTMENTS**

The Neutral Start Switch (NSS) provides a means to prevent the system prime mover from starting while the pump control handle is in-stroke. When the control input shaft is in its neutral position, the switch pin engages a slot on the eccentric cam attached to the control shaft. This allows the spring loaded NSS to close, completing the electrical starting circuit for the prime mover. When the control input shaft is not in its neutral position, the eccentric cam opens the NSS switch.

The neutral start switch is threaded into the special lock nut for the eccentric plug. Turning the NSS clockwise (CW) moves the NSS closer to the switch cam on the control shaft, and narrows the NSS deadband. Turning the NSS counterclockwise (CCW) moves the NSS farther from the switch cam on the control shaft, widening the NSS deadband. The switch pin is located in an eccentric plug which is turned to move the center of the NSS deadband.

MDC with neutral start switch

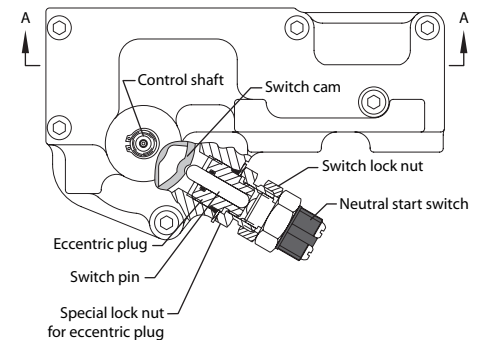

View at section A-A

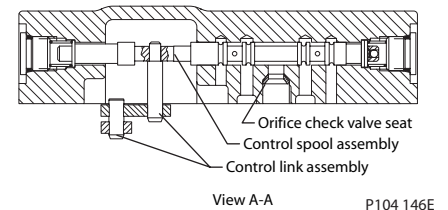



MDC NEUTRAL START SWITCH (NSS) ADJUSTMENTS (continued)

Adjust the Neutral Start Switch to meet the following three requirements:

- i. The distance you can move the control handle without opening the NSS is the **NSS deadband**. The distance you can move the control handle without moving the control spool enough to port hydraulic fluid to the pump displacement control cylinders is the **control deadband**. These deadbands must be concentric.

Since you cannot adjust the position of the control deadband, you must adjust the position of the NSS deadband to match it.

- ii. The NSS deadband must be wide enough so the NSS will not open within the loose area of control handle movement caused by normal operating clearances in the control linkage (control shaft free-play).

By setting the NSS to open outside this area, the control spool springs or control shaft centering spring can always return the handle to neutral and re-close the NSS.

- iii. The NSS deadband must be narrow enough so the NSS will open before the unit builds 7 bar [100 psi] differential system pressure in either direction.

Neutral start switch adjustment requirements

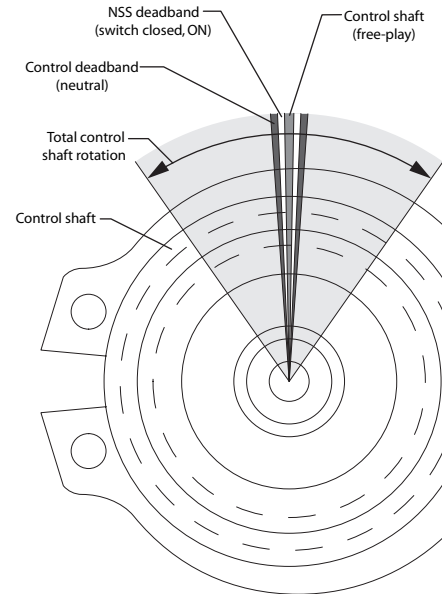

P104 147E



**MDC NEUTRAL
 START SWITCH (NSS)
 ADJUSTMENTS
 (continued)**

**Neutral start switch eccentric plug
 adjustment (condition i)**

Center the NSS deadband and the control deadband in relation to each other. Since you cannot adjust the position of the control deadband, you must adjust the position of the NSS deadband to match it. The switch pin is located in an eccentric plug which you turn to move the center of the NSS deadband. Ensure the MDC is installed on the pump and in its neutral position when adjusting the neutral start switch eccentric plug. The accompanying drawing provides dimensions for an eccentric plug adjustment tool.

Warning
 Do not start the prime mover while the neutral start switch is removed from the control. Case pressure will force the pin out of the eccentric plug, causing oil loss.

1. Hold the switch and eccentric plug from turning and use a 1-1/8 inch wrench to loosen the lock nut. Remove the neutral start switch.
2. Note the slots on the eccentric plug for the adjustment tool. Hold the eccentric plug in place with the adjustment tool, and loosen the lock nut with a 1-1/8 inch wrench.
3. Position the eccentric plug so the switch pin is offset toward the control mounting surface. This will provide the best contact between the pin and the cam on the control shaft.

Eccentric plug adjustment tool

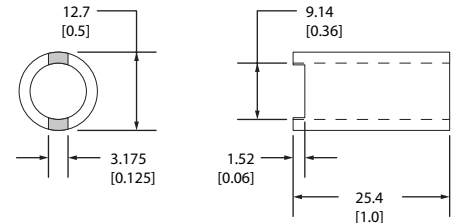

P104 149E

NSS with eccentric plug

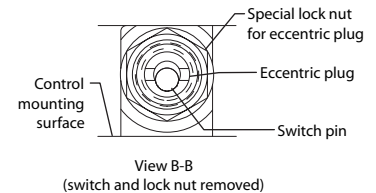
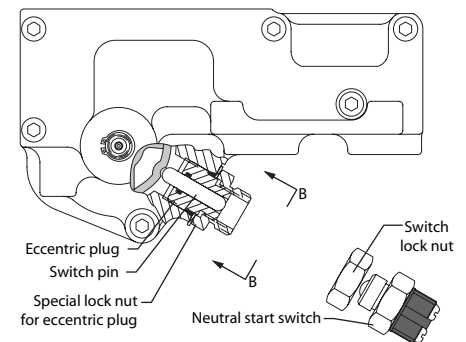

P104 150E



**MDC NEUTRAL
START SWITCH (NSS)
ADJUSTMENTS
(continued)**

4. Hold the control shaft in its neutral position (in the center of the control shaft free-play area). Locate the switch pin in the slot of the switch cam by turning the eccentric plug while checking the pin position (depth) in the plug. When the pin engages the cam slot, the pin will be at its maximum depth in the plug. Hand tighten the plug lock nut to hold the eccentric plug in position.

Eccentric plug adjustment

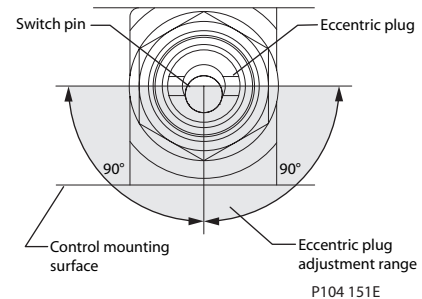

5. Turn the control shaft an equal amount in either direction from neutral. The switch pin should move out of the eccentric plug an equal distance when the control shaft is turned. Turn the eccentric plug to center the switch pin with the cam slot. Only a small amount of adjustment in either direction is needed to center the pin.
6. While holding the eccentric plug in place, tighten the eccentric plug lock nut to 27 N•m [20 lbf•ft]. Reinstall and adjust the switch as outlined in the previous section.

The eccentric plug normally requires between 5-1/2 and 6-1/2 turns to install into the control housing.

⚠ Caution

Do not turn the eccentric plug into or out of the housing beyond specifications.

7. Once the switch is correctly adjusted, hold the switch in place and tighten the lock nut to 27 N•m [20 lbf•ft] torque.

NSS deadband adjustment (conditions ii & iii)

The NSS deadband must be wide enough so the NSS will not open within the control shaft free-play area, and it must be narrow enough so the NSS will open before the unit builds 7 bar (100 psi) differential system pressure in either direction.

1. Install two 1000 bar [10 000 psi] pressure gauges in the system pressure gauge ports M1 and M2.
2. Using two 1-1/8 inch wrenches, hold the neutral start switch from turning and loosen the lock nut.
3. Disconnect the external control linkage and make certain the control shaft is in its neutral position.
4. Attach a continuity checker to the terminals of the switch. With the control shaft in its neutral position, turn the switch clockwise (CW) until the switch opens, then turn the switch counterclockwise (CCW) until it closes. Turn the switch counterclockwise (CCW) an additional 1/4 turn (90°) after the switch closes.



**MDC NEUTRAL
START SWITCH (NSS)
ADJUSTMENTS
(continued)**

5. Hold the switch in place and tighten the lock nut to 27 N·m (20 lbf·ft) torque.
6. With the continuity checker attached to the switch, rotate the control handle (or the control shaft) in each direction to assure the switch opens when the control is not in the neutral position.
7. If the switch closes in neutral and satisfactorily opens in each direction, proceed to check the switch with the prime mover running. The switch must open before the unit builds 7 bar [100 psi] differential system pressure in either direction.

Neutral start switch

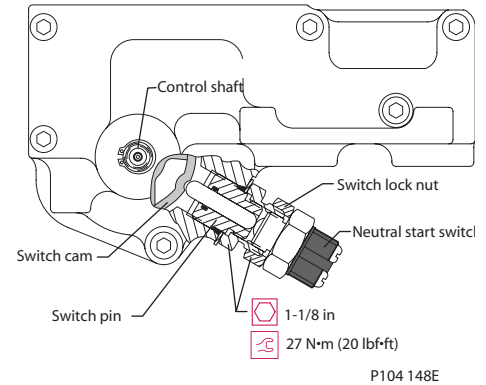

If the switch opens after the unit builds system pressure in either direction, loosen the switch lock nut and turn the switch clockwise (CW) 1/12 turn (30°). Tighten the switch lock nut and recheck the switch operation. Repeat this procedure if necessary.

8. If the switch does not open with an equal movement of the control handle in each direction, turn off prime mover, remove the pressure gauges, and continue with the next section.
9. If neutral start switch operation is satisfactory, turn off the prime mover, remove the pressure gauges, and reconnect the external control linkage.

Series 90 Axial Piston Closed Circuit Pumps Service Manual Adjustments



CHECKING SWITCH CONTINUITY

Warning

The following procedure may require the vehicle/machine to be disabled (wheels raised off the ground, work function disconnected, etc.) while performing the procedure in order to prevent injury to the technician and bystanders. Take necessary safety precautions before moving the vehicle/machine.

Recheck switch continuity to determine whether additional adjustment of the eccentric plug is necessary. **Warning**

1. Install a 50 bar [1000 psi] gauge in each of the two servo cylinder gauge ports (M4 and M5). Attach a continuity checker to the terminals of the neutral start switch.

Checking switch continuity

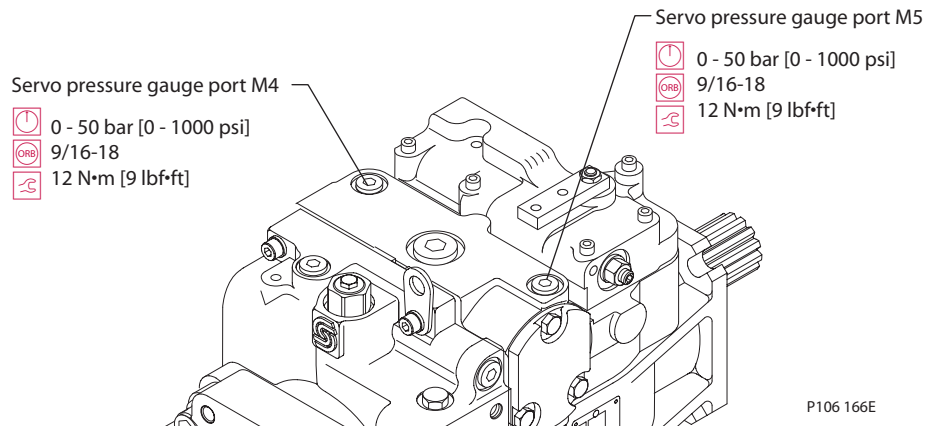

2. Energize the starter circuit, and start the prime mover.
3. While operating at normal speed and with the pump in its neutral (zero flow) position, note the pressure reading on the gauges. Note this reading as the base pressure.
4. Slowly move the control handle in one direction while observing the pressure gauges and the continuity checker. The switch must open before the pressure on either gauge increases more than 1 bar [14.5 psi] from the base pressure obtained at neutral.
5. Slowly move the control handle in the opposite direction. Again, The switch must open before the gauge pressure increases more than 1 bar [14.5 psi] from base pressure.
6. Verify continuity again when the control is returned to neutral.
7. If the switch does not open at base pressure plus 0 to 1 bar [0 to 14.5 psi] in either direction, stop the prime mover and readjust the eccentric plug as described in the previous section. If the pressure difference is equal in each direction but greater than 1 bar [14.5 psi], loosen the switch lock nut and turn the switch clockwise 1/12 turn (30°) to increase the sensitivity. Retighten the lock nut and recheck pressure differences and continuity.
8. After verifying proper control and switch operation, stop the prime mover. Remove the continuity checker and pressure gauges. Reinstall the servo pressure port plugs and reconnect the electrical leads from the machine starter circuit to the NSS. Install and adjust, the external control linkage if necessary.

Series 90 Axial Piston Closed Circuit Pumps Service Manual Adjustments



HYDRAULIC DISPLACEMENT CONTROL (HDC) AND ELECTRIC DISPLACEMENT CONTROL (EDC) ADJUSTMENT

The neutral adjustment is the only adjustment that can be made on hydraulic and electric displacement controls. All other functions are preset at the factory.

Make this adjustment on a test stand or on the vehicle/machine with the prime mover operating. ⚠

⚠ Warning

The following procedure may require the vehicle/machine to be disabled (wheels raised off the ground, work function disconnected, etc.) while performing the procedure in order to prevent injury to the technician and bystanders. Take necessary safety precautions before moving the vehicle/machine.

HDC and EDC neutral adjustment

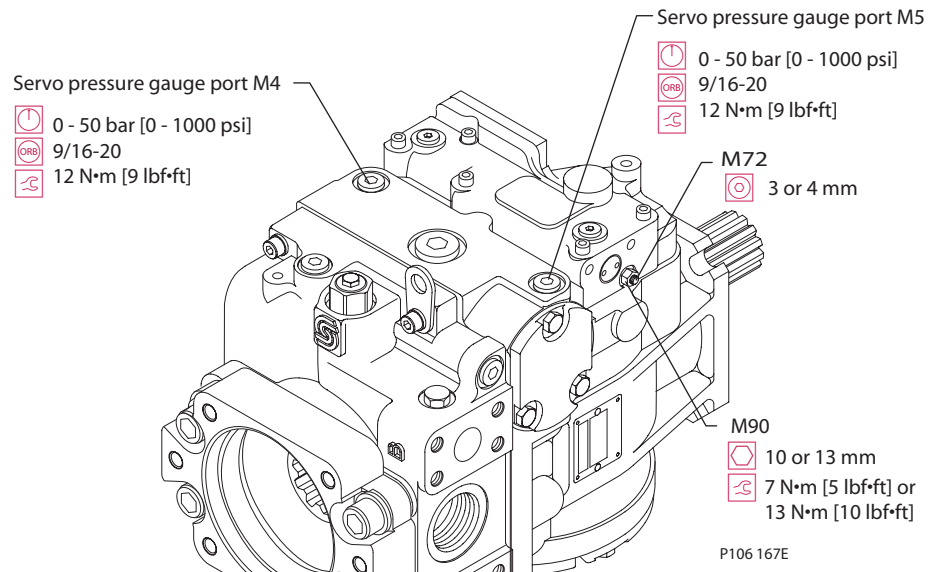

1. Install a 50 bar [1000 psi] gauge in each of the two displacement control cylinder gauge ports (M4 and M5). Disconnect the external control input (hydraulic or electronic) from the control. Start the prime mover and operate at normal speed.
2. Loosen the lock nut (M90) with a 10 mm or 13 mm hex wrench.
3. Using a 3 mm or 4 mm internal hex wrench, rotate the adjusting screw (M72) clockwise until the pressure increases in one of the pressure gauges. Note the angular position of the wrench. Rotate the neutral adjusting screw counterclockwise until the pressure increases by an equal amount on the other gauge. Again note the angular position of the wrench.
4. Rotate the adjusting screw clockwise half the distance between the locations noted above. The gauges should read the same pressure (case pressure), indicating that the control is in its neutral position.
5. Hold the neutral adjusting screw stationary. Tighten the neutral adjusting screw lock nut to 7 N•m [62 lbf•in] for the 6 mm screw or 13.5 N•m [120 lbf•in] for the 8 mm screw. Do not overtorque the nut.
6. Once the neutral position is set, stop the prime mover, remove the gauges, and install the gauge port plugs. Reconnect the external control input.

Series 90 Axial Piston Closed Circuit Pumps

Service Manual

Adjustments



SPEED SENSOR ADJUSTMENT

When installing or adjusting the speed sensor on a pump, it must be set at a specific distance from the speed ring on the unit's cylinder. To locate the position of the speed sensor on the unit or description see the corresponding section.

1. Loosen the sensor lock nut with an 11/16 inch hex wrench.
2. Turn the sensor clockwise (CW) by hand until it contacts the speed ring.
3. Turn the sensor counterclockwise (CCW) 1/2 turn (180°) to establish the nominal gap of 0.71 mm [0.028 inch].
4. Then turn the sensor clockwise (CW) until the wrench flats on sensor body are positioned at a 22° angle to the pump shaft center line.

Cross section view of speed sensor in variable pump

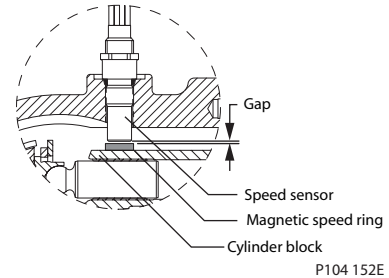

Positioning speed sensor relative to pump shaft

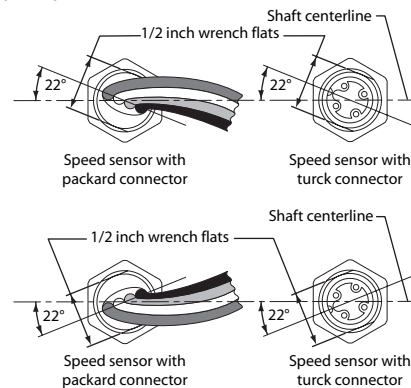

Most open-end wrenches have a 22° handle offset.

5. The final sensor position should be between 1/2 (180°) and 1/4 turn (90°) counterclockwise (CCW) from the point where the sensor contacts the speed ring.
6. Hold sensor in position with a 1/2 inch hex wrench while tightening the lock nut to 13 N•m [10 lbf•ft].



STANDARD PROCEDURES **Removing the pump**

Before working on the pump, clean the outside of the pump. If the pump has an auxiliary pump attached, remove both pumps as a single unit. Tag and cap all hydraulic lines as they are disconnected and plug all open ports to ensure that contamination does not enter the system.

⚠ Caution

Contamination can damage internal components and void your warranty. Take precautions to ensure system cleanliness when removing and reinstalling system lines

Disassembly

1. With the prime mover off, thoroughly clean the outside of the pump.
2. Tag, cap, and disconnect each hydraulic line connected to the pump. As hydraulic lines are disconnected, plug each open port, to ensure that dirt and contamination do not enter the system.
3. Remove the pump and its auxiliary pump (if applicable) as a single unit.

Inspection

4. Ensure the work surface and surrounding area are clean and free of contaminants.
5. Inspect the system for contamination.
6. Look at the hydraulic fluid for signs of system contamination, fluid discoloration, foam, sludge, or small metal particles.

Reassembly

7. Before replacing the pump on the machine, replace all filters and drain and fill the hydraulic system with the correct hydraulic fluid.
8. Flush the lines before replacing the hydraulic fluid.



SHAFT SEAL AND SHAFT REPLACEMENT

You can replace the shaft and seal without major disassembly of the unit. Clean pump and surrounding area thoroughly. Disconnect and remove the pump from the unit, and clean it thoroughly before starting repairs. Mark all connections for later reassembly.

Shaft removal

1. Position the pump with the shaft facing up.

If the unit is positioned horizontally, or moved or jarred while the shaft is out, the cylinder block could move out of place, making shaft installation difficult.

2. Remove the three or four screws (L70) holding the retainer plate (L60) and seal carrier (L30) to the housing, using a 10 mm hex wrench (042 unit), a 5 mm internal hex wrench (055 through 100 units), or a 6 mm internal hex wrench (130 through 250 units). Remove the retainer plate.

Certain earlier production units use a one piece retainer plate and seal carrier.

3. After removing the screws, the spring force on the shaft may move the seal carrier out of its bore by approximately 5 mm [1/4 inch]. If the seal carrier does not move from its bore, pry it from its bore and/or lightly tap the end of the shaft with a soft mallet.
4. Remove the O-ring (L50) from the seal carrier and discard.
5. Place seal carrier and seal in an arbor press and press out the seal (L40).
6. Remove shaft (L100) and roller bearing assembly (L10) from pump. You can transfer the bearing assembly to the new shaft.
7. Using snap-ring pliers, remove the retaining ring (L20) that secures the roller bearing assembly. Remove the roller bearing assembly.

Shaft assembly

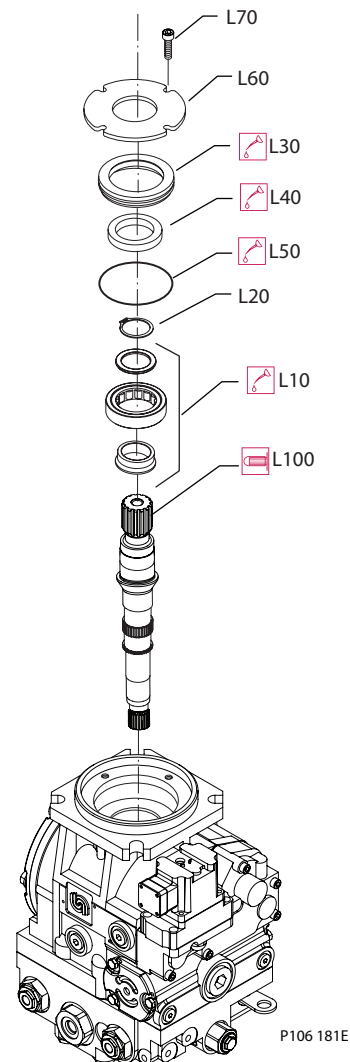



Series 90 Axial Piston Closed Circuit Pumps

Service Manual

Minor repair



SHAFT SEAL AND SHAFT REPLACEMENT (continued)

Inspection

8. Inspect the seal carrier, the new seal and the O-ring for any damage or nicks.
9. Inspect the shaft and bearing for rust, wear, or contamination. Spin the bearing in your hand feeling for roughness. Replace if necessary.

Reassembly

10. Using the arbor press, press the new seal (L40) into seal carrier (L30). Be careful not to damage the seal.

If the shaft is not being replaced proceed to step 12.

11. Place roller bearing assembly on new shaft and secure with the retaining ring.
12. Install an installation sleeve or wrap spline or keyed end of shaft with plastic film to prevent damage to the sealing lip on the seal during installation.
13. Lubricate and install a new O-ring (L50) on the seal carrier. Lubricate the seal with clean petroleum jelly.
14. Assemble the seal carrier and seal over the shaft and into the housing bore. Install the retainer plate (if used).
15. Install the screws and torque to the appropriate value in the table to the right.

Shaft retainer screw torque

Frame size	Torque
030 – 042	12 N•m [9 lbf•ft]
055 – 100	16 N•m [12 lbf•ft]
130 – 250	32 N•m [24 lbf•ft]

Torque the screws in a sequenced pattern then recheck.



MULTI-FUNCTION VALVE CARTRIDGES

Multi-function valve removal / installation

Older multifunction valves (pre 1988) contain different components. See *multifunction valves - Pre 1988*, (page 52) for disassembly instructions.

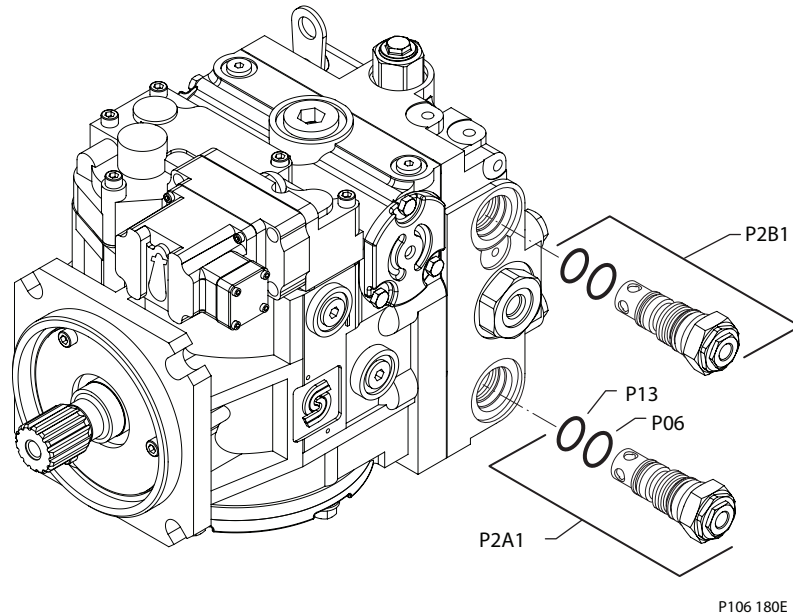

Removal

1. Remove multi-function valves (P2A1 and P2B1) using hex wrench listed in table.
2. Remove and discard O-rings (P13 and P06).
3. Relieve spring pressure by removing bypass actuator (P03), using a 1-1/16 wrench. To retain pressure setting, do not separate adjusting screw (P01), and locknut (P04) from bypass actuator (P03).
4. Remove and discard O-ring (P02).

Multi-function valve wrench size

Frame size	Wrench size
030 – 100	1-1/4 inch
130 – 250	1-5/8 inch

Multi-function valves are sold as complete units only. You may purchase O-rings separately.

5. The poppet seat section is pressed over a lip. Place the cartridge in a vise and pry the poppet seat (P12) off with an appropriate tool. Maintain sufficient control to prevent the internal components from flying loose. Do not damage parts during disassembly.
6. Remove internal parts (P07, P08, P17, P16, P15, P14, P09, and P11).

**MULTI-FUNCTION VALVE
 CARTRIDGES
 (continued)**

Multi-function valve

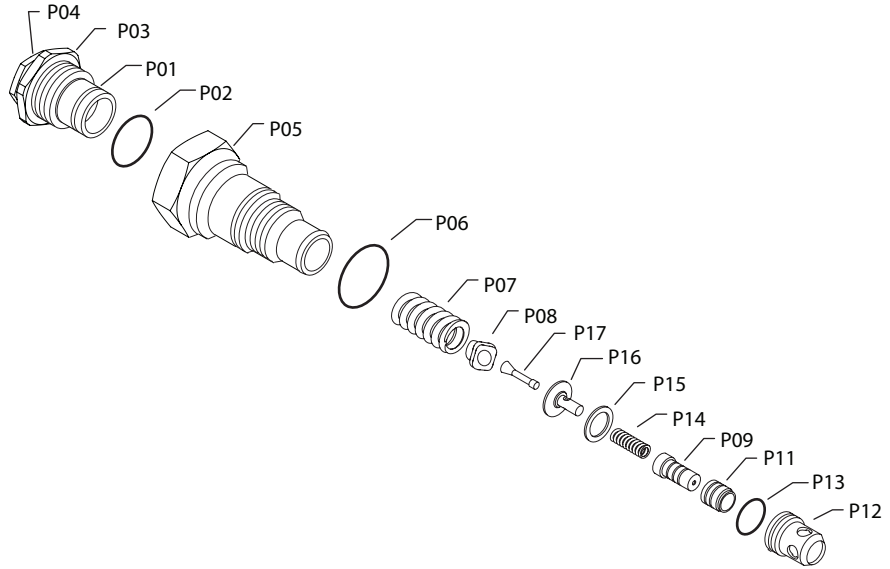

E101 531E

Inspection

- Clean and inspect all disassembled parts.

Reassembly

- Lubricate and install internal components (P07, P08, P17, P16, P15, P14, P09, P11, and P12).
- Place the cartridge in a vise and press on the poppet seat (P12).
- Lubricate and install new O-rings (P02, P06, P13).
- Install bypass actuator (P03) with pressure limiter valve (P01). Torque to 40 N•m [30 lbf•ft]

Caution

If pressure limiter (P01) was removed from bypass actuator (P03), adjust pressure limiter to model code specifications.

Caution

Do not overtorque the multi-function valve cartridges

- Install cartridges and torque as shown in the table. **Caution**

Multi-function valve torque

Frame size	Torque
030 – 100	89 N•m [66 lbf•ft]
130 – 250	210 N•m [155 lbf•ft]



**MULTI-FUNCTION VALVE
 CARTRIDGES - PRE 1988**

Removal

1. Remove multi-function valves using hex wrench listed in table.
2. Remove and discard O-rings (P03 and P06).
3. It is not necessary to remove the bypass function (P14) except for cleaning. Wrench size is 1-1/16.

Multi-function valve wrench size

Frame size	Wrench size
030 – 100	1-1/4 inch
130 – 250	1-5/8 inch

Multi-function valves are sold as complete units only. O-rings may be purchased separately.

4. To retain pressure setting, do not disassemble bypass function (P14).
5. Remove retaining ring (P22) with a snap ring pliers.
6. Remove poppet seat (P12).
7. Remove internal parts (P21, P15, (P14, P09, and P11).

Inspection

8. Clean and inspect all disassembled parts.

Multi-function valve - pre 1988

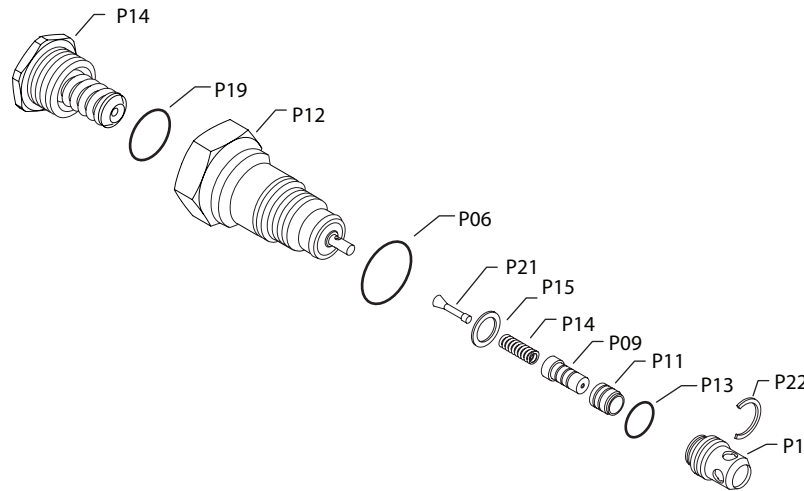

E101 532E

**MULTI-FUNCTION VALVE
 CARTRIDGES - PRE 1988
 (continued)**

Reassembly

9. Lubricate and install internal components (P01, P11, P09, P14, P15, and P21).
10. Install poppet seat (P1).
11. Install retaining ring (P22).
12. If previously removed, lubricate and install O-ring (P19).
13. If previously removed, reassemble and install bypass actuator (P14). Torque to 40 N•m [30 lbf•ft].
14. Lubricate and install new O-rings (P06, P13).

Caution

If pressure limiter was removed from bypass actuator (P14), adjust pressure limiter to model code specifications.

Caution

Do not overtorque the multi-function valve cartridges

15. Install cartridges and torque as shown in the table below. **Caution**

Multi-function valve torque

Frame size	Torque
030 – 100	89 N•m [66 lbf•ft]
130 – 250	210 N•m [155 lbf•ft]

**PRESSURE OVERRIDE
 VALVE (OPTION FOR 180
 FRAME SIZE)**

Removal

1. Remove the four screws attaching the pressure override valve to the pump end cap with a 5 mm internal hex wrench. Remove and discard the O-rings.

Inspection

2. Clean and inspect valve for damage to parts.

Reassembly

3. Install new O-rings. Install the valve onto the pump end cap and torque the screws to 16 N•m [12 lbf•ft].

Pressure override valve components

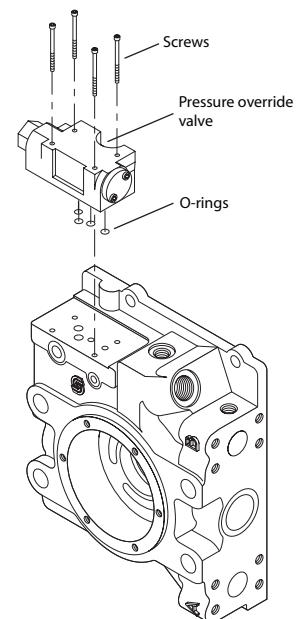

E101 079E

Series 90 Axial Piston Closed Circuit Pumps

Service Manual

Minor repair



CHARGE PRESSURE RELIEF VALVE

The charge pressure relief valve is shim adjustable (early models) or screw adjustable (late models). Screw adjustable charge relief valve is shown.

Removal

1. Remove the shim adjustable charge relief valve plug with a 1 inch hex wrench.

Before removing the screw adjustable relief valve plug, mark the plug (K90), lock nut (K10), and housing to approximately maintain the original adjustment when assembling. Remove the screw adjustable charge relief valve plug by loosening the lock nut with a hex wrench corresponding to the table.

Unscrew the plug using a large screwdriver or 1/2 inch hex wrench. Remove and discard the O-ring (K50).

2. Remove the spring (K70) and relief valve poppet (K80).

Inspection

3. Inspect the poppet (K80) and mating seat in the endcap for damage or foreign material.

When inspecting shim adjustable valves, do not alter the shims or interchange parts.

Reassembly

4. Install the poppet (K80) and spring (K70). For shim adjustable valves, install the shims and plug, torque to 68 N•m [50 lbf•ft]. For screw adjustable valves, install the plug with its lock nut, aligning the marks made at disassembly, and torque the lock nut to 52 N•m [38 lbf•ft].

Check the charge pressure and adjust, if necessary. Refer to *Charge pressure adjustments* (page 31).

Lock nut wrench size

Frame size	Wrench size
030 – 100	1-1/16 inch
130 – 250	1-5/8 inch

Charge pressure relief valve

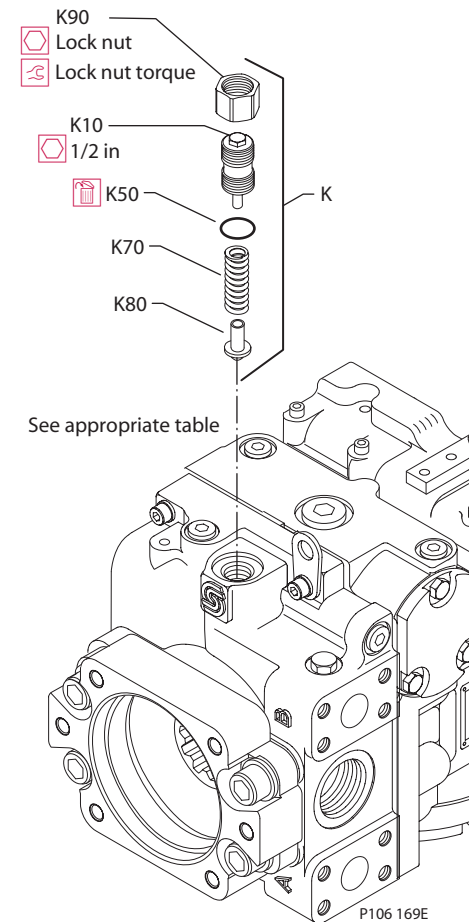

AUXILIARY PAD

Removal

1. Remove the four end cap screws (J80). Remove and discard special washers (J70).

Caution

On earlier production frame size 75 pumps with twin ports, secure the end cap to the pump housing with a clamp to avoid gasket damage.

2. Remove the auxiliary pad (J60) and discard the O-rings (J50 and J90).

Aux. pad screw wrench size

Frame size	Wrench sizes
030 – early 042	8 mm internal hex
late 042	10 mm internal hex
055	19 mm hex
075 – 100	24 mm hex
100 – 130	14 mm internal hex
180 – 250	17 mm internal hex

Inspection

3. Inspect the auxiliary pad for damage and replace if necessary.
4. Take care to assure the surfaces are clean and free of any foreign material or paint prior to installing the auxiliary pad.

Caution

Do not allow the force of the cylinder block spring and swashplate leveler springs to separate the end cap from the pump housing. Gasket damage and external leakage may result.

Auxiliary pad components (typical)

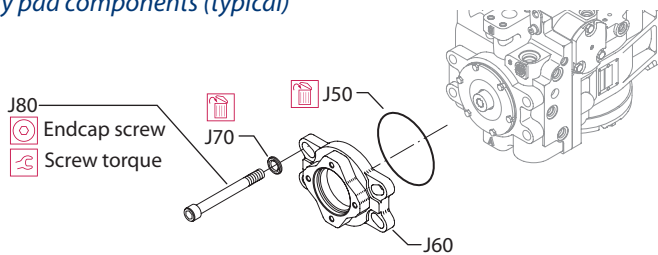

See appropriate table for wrench size and torque

E101 084E

Inspection

5. Inspect the auxiliary pad components for wear or damage and replace if any is found.
6. Take care to ensure the surfaces are clean and free of any foreign material or paint prior to installing the auxiliary pad.

Reassembly

7. Lubricate and install O-ring (J50) on end cap pilot.

8. Install the auxiliary mounting pad (J60) on rear of endcap.

End cap screw torque

Frame size	Torque
030	58 N•m [43 lbf•ft]
042	75 N•m [55 lbf•ft]
055	122 N•m [90 lbf•ft]
075 – 130	298 N•m [220 lbf•ft]
180 – 250	580 N•m [429 lbf•ft]

9. Install four large screws (J80) and new washers (J70) through the mounting pad and end cap into the housing. Torque per the accompanying table.

Torque endcap screws in a criss-cross pattern



CHARGE PUMP

The following procedure shows how to remove and install a charge pump.

Removal

1. For pumps with an auxiliary mounting pad, refer to the *Auxiliary Pad* instructions (page 55).

Caution

On earlier production frame size 75 pumps with twin ports, secure the endcap to the pump housing with a clamp to avoid gasket damage.

2. Remove the six screws (H80) holding the charge pump cover retainer (H70).
3. Remove the retainer (H70) and the charge pump cover (J15). Remove and discard O-ring (J50). Note the orientation of the gerotor assembly (H05).

Retainer screw wrench size

Frame size	Wrench size
030 – 100	10 mm
130 – 250	13 mm

Current charge pump configuration

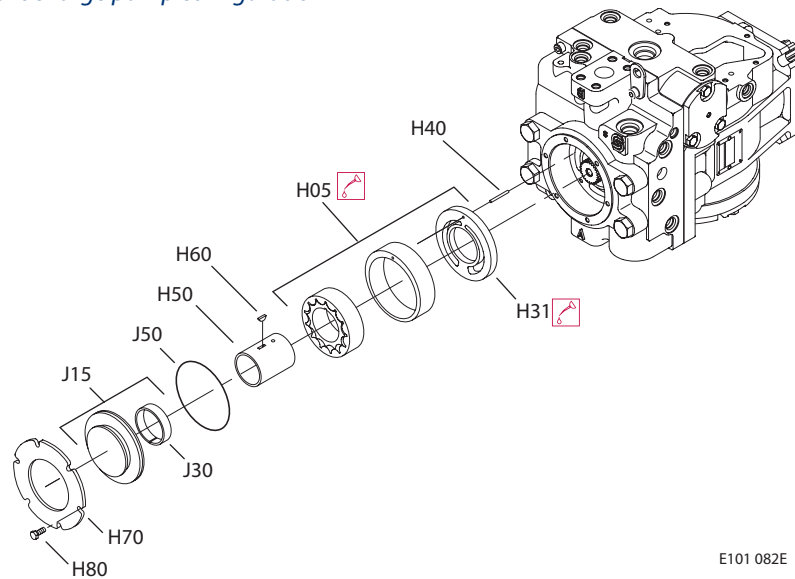

E101 082E

Refer to appropriate *Sauer-Danfoss Series 90 service parts manual* for earlier charge pump configurations.

4. Remove the charge pump coupling (H50) and charge pump drive key (H60).
5. Remove the charge pump gerotor assembly (H05).

CHARGE PUMP (continued)

6. Remove the alignment pin (H40).
7. Remove the inner port plate (H31).

Inspection

Inspect all parts for abnormal wear or damage and replace if necessary.

If installing a different displacement charge pump, the gerotor assembly, gerotor outer eccentric ring, and inner port plate (early and late production pumps) or outer spacer plate(s) (intermediate production pumps) must be replaced together. If different thickness port plates are used in an early production charge pump assembly, the thicker plate is the inner port plate (installed next to the pump end cap).

Different production charge pump assemblies include a different quantity / type of port plates and spacer plates.

Reassembly

Be sure to install the charge pump in the proper orientation. If unsure of charge pump rotation, refer to the model code.

The orientation of the gerotor assembly outer eccentric ring and the location of the alignment pin in the end cap determine the charge pump rotation..

Do not mix charge pump parts from different production periods. Always install as a complete assembly.

Orienting alignment pin

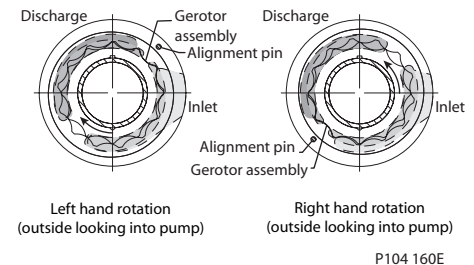

8. Install the inner port plate (H31) and the gerotor assembly outer ring.
9. Install the alignment pin (H40) to properly orient the port plates and outer eccentric ring for corresponding pump rotation.
10. Prior to installation, lubricate the I.D., O.D., and side faces of the gerotor assembly.
11. Install the gerotor assembly (H05).
12. Install the outer port plate (early production and intermediate production pumps only).
13. Install the spacer plate, if present (intermediate production pumps).
14. Install the charge pump drive key (H60) into the charge pump coupling (H50) and retain with petroleum jelly.

Series 90 Axial Piston Closed Circuit Pumps Service Manual Minor repair



CHARGE PUMP (continued)

Intermediate production 75 cm³ and 100 cm³ pumps use the same charge pump coupling. Two keyways are provided in the coupling for the charge pumps used in these units. The rear keyway (with identifier groove) is used in 75 cm³ pumps. The front keyway (closest to the internally splined end of the shaft) is used in 100 cm³ pumps.

8. Install the charge pump coupling. The internally splined end of the coupling must engage the main pump shaft.

The outside diameter of the internally splined end of some early production charge pump couplings were chamfered. Early production end caps may not be machined to accept a non-chamfered coupling. Always use a chamfered charge pump coupling in pumps with the early endcap.

9. For pumps with an auxiliary mounting pad, install the auxiliary drive coupling.
10. For pumps with no auxiliary pad, install a new O-ring (J50) onto charge pump cover. (If an auxiliary pad is installed, an O-ring is not used on the cover.)
11. Carefully remove the alignment pin from the charge pump parts. Install the pin in its hole in the charge pump cover (J15) (see previous page for correct orientation) and retain with petroleum jelly. Install the cover (with alignment pin) into the end cap and aligned charge pump parts. (Take care not to damage the cover O-ring, if used.)

⚠ Caution

In order to avoid loss of charge pressure in pumps with an auxiliary mounting pad, always install the charge pump cover with the pad drain hole located on the same side of the end cap as the charge inlet port. Refer to the section "Auxiliary Pad Installation" for details.

12. Install the charge pump cover retainer (H70) and the six internal hex screws (H80). Torque the screws per the table at the right..

Retainer screw torque

Frame size	Torque
030 – 100	16 N•m [11.85 lbf•ft]
130 – 250	32.5 N•m [24 lbf•ft]

13. For pumps with auxiliary mounting pads, install the O-ring and auxiliary mounting pad adaptor onto the end cap. Refer to the corresponding section for instructions on auxiliary pad installation.

ADDING AN AUXILIARY PAD TO A PUMP PREVIOUSLY WITHOUT ONE

1. If installing an auxiliary pad kit on a pump that was previously without one, carefully remove the alignment pin from the charge pump parts.
2. Install the pin in its hole in the new charge pump cover (with hole for the auxiliary coupling) and retain with petroleum jelly.
3. Install the new charge pump cover with alignment pin into the end cap and the aligned charge pump parts.
4. Lubricate and install O-ring. Install auxiliary pad. Refer to previous sections, *Auxiliary pad*, page 55, and *Charge pump*, page 56, for instructions.

INTEGRAL CHARGE PRESSURE FILTER REPLACEMENT

Removal

1. Remove the filter canister (N40) from the filter head (N10) as described on the canister.
2. Hold the filter head in place and loosen the lock nut (N20) using the wrench size corresponding to pump frame size.
3. Rotate the filter head counterclockwise to remove it from the housing. Remove and discard the O-ring (N15).
4. Remove the hydraulic tube (N25) from its bore in the endcap.

Lock nut wrench size and torque

Frame size	Wrench size	Torque
030 – 042	1-3/8 inch	70 N•m [52 lbf•ft]
055 – 130	1-5/8 inch	122 N•m [90 lbf•ft]
180 – 250	1-5/8 inch	156 N•m [115 lbf•ft]

Inspection

5. Inspect the filter head and lock nut sealing surfaces. If you find any nicks or scratches, replace the damaged components.

Reassembly

6. Install the hydraulic tube (N25) into its bore in the endcap. Install the filter head (N10) into the port using a new O-ring (N15). The hydraulic tube should go in with low force.
7. After rotating the filter head clockwise so that the threads engage with the threads in the endcap, continue to rotate it clockwise between 6 and 7 revolutions. Position head as desired.
8. While holding the filter head in the desired position, tighten the swivel lock nut (N20) and torque as shown in table.
9. Install a new filter canister (N40) per the instructions on the filter canister.

Caution

Failure to install the filter manifold or filter head to a sufficient depth in the end cap will result in insufficient engagement of the tube in the end cap bore. This may allow unfiltered oil to bypass the filter and enter the charge system.

Integral charge pressure filter

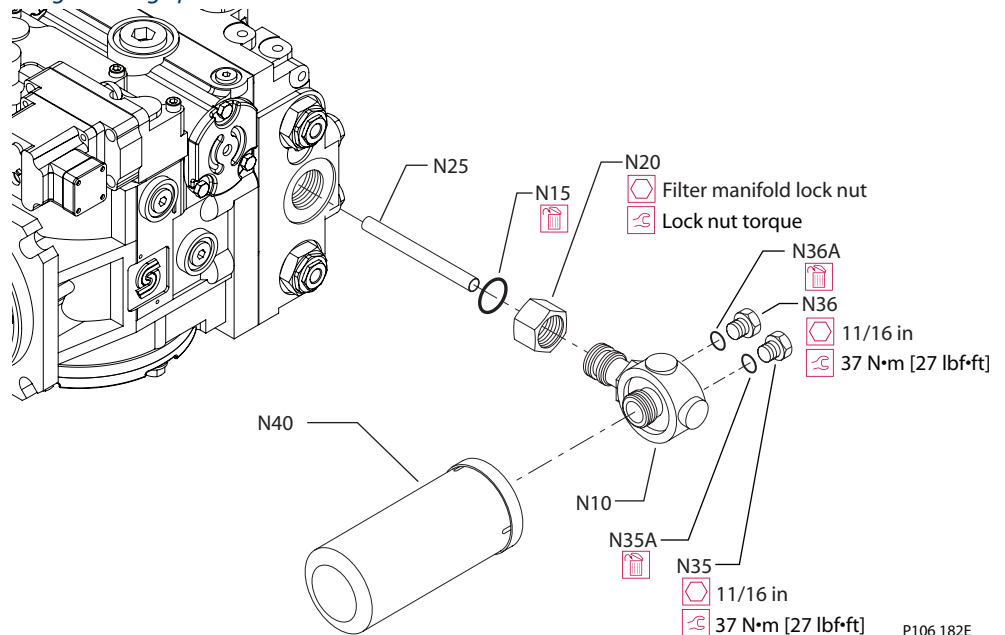



**PUMP CONTROL COVER
PLATE**

Removal

1. Thoroughly clean external surfaces prior to removal of cover plate.
2. Using a 5 mm internal hex wrench, remove the six cover plate mounting screws (M90). Remove the cover plate (M1) and gasket (M11) from housing. Discard the gasket.

Caution

Protect exposed surfaces and cavities from damage and foreign material.

Reassembly

3. Install a new gasket on the housing. Install the cover plate and install the screws. Torque the screws to 16 N•m [12 lbf•ft].

Install a sealing washer under the head of any mounting screws that are installed into through holes in the housing.

Pump controls cover plate

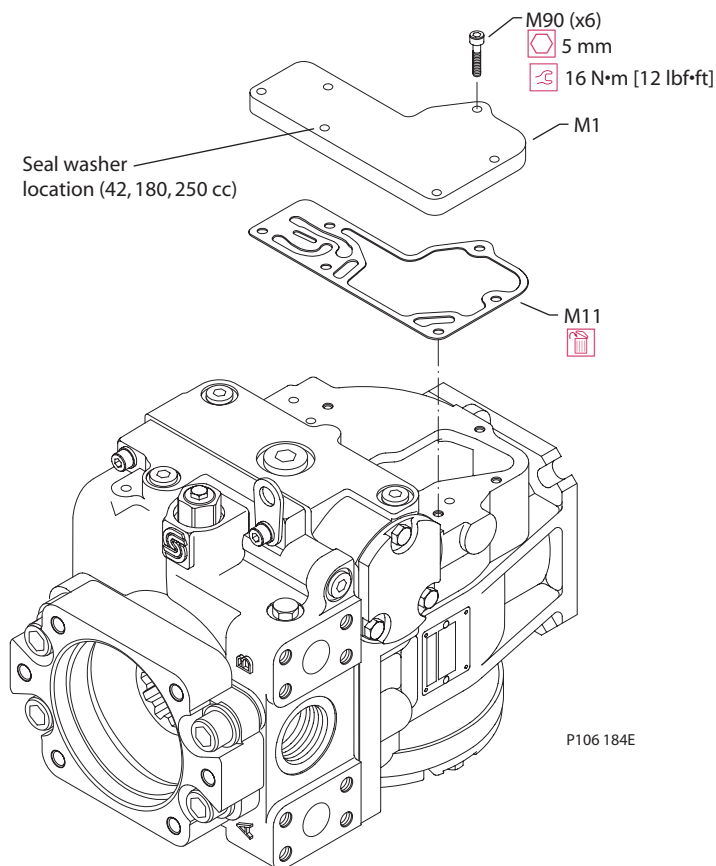



DISPLACEMENT CONTROL ORIFICES

1. Remove the control assembly as described in the instructions for the specific displacement control.
2. Orifice plugs may be located in the control assembly, at the pump housing face. Remove the orifice plugs one at a time (to avoid mixing them up) with a 4 mm internal hex wrench. Note the location of each plug, do not interchange plugs. Clean, reinstall, and torque the orifice plugs to 3 N•m [2.2 lbf•ft].

Underside of an HDC/EDC module showing orifice locations

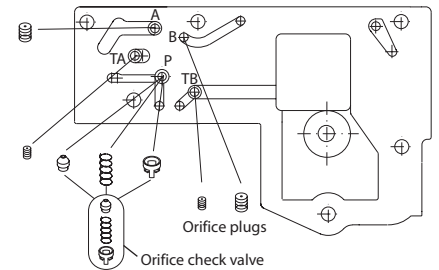

E101 085E

3. Assemble the control onto the pump. Refer to the instructions for the specific control.

DISPLACEMENT CONTROL ORIFICE CHECK VALVE

1. Remove the control assembly as described in the instructions for the specific displacement control.
2. The orifice check valve is located in the control assembly, at the surface of the pump housing face. Remove the spring retainer and spring from the orifice check valve cavity and then remove the orifice check valve.
3. Clean and install the orifice check valve in the cavity and then install the spring and spring retainer to hold the orifice check valve in position.

Underside of an MDC module showing orifice locations

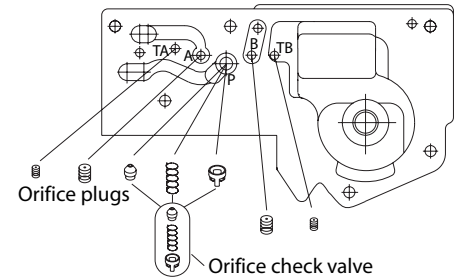

E101 086E

4. Assemble the control onto the pump. Refer to the instructions for the specific control.

DISPLACEMENT CONTROL ADAPTER PLATE (EARLY PRODUCTION 130 PUMPS ONLY)

Do not remove the adapter plate unless leakage is evident. The mounting screws with sealing compound are difficult to remove.

The screws fastening the control adapter plate to the housing have sealing compound on the threads. You may remove them with a 6 mm internal hex wrench if necessary. Remove and discard the O-rings and seals.

When installing the adapter plate, replace screws (with sealing compound), and ensure the new O-rings and seal are in the proper position. Torque the screws to 32 N•m [24 lbf•ft].

Displacement control adapter plate (early production 130 cm³ pumps only)

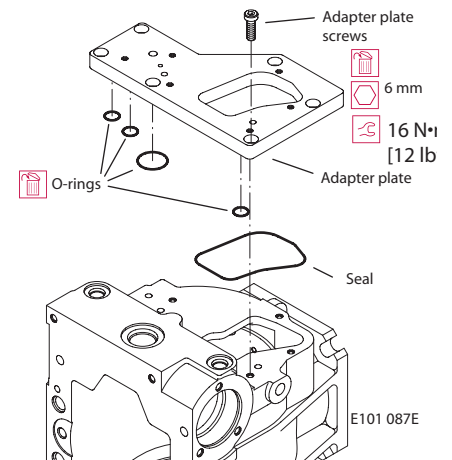

E101 087E



MANUAL DISPLACEMENT CONTROL (MDC)

Removal

1. Thoroughly clean external surfaces prior to removal of control.
2. Using a 5 mm internal hex wrench, remove the six control mounting screws (M90). Remove the control (M1) (with orifice check valve (T40) and spring (T30)) and control gasket (M11) from the housing. Discard the gasket.

If necessary, remove the control handle (M70) by removing the locking nut (M72) and washer (M71).

Caution

Protect exposed surfaces and cavities from damage and foreign material.

Reassembly

3. Install a new gasket (M11). Inspect control to assure that the control orifice check valve and spring are in their proper position in the control.
4. Install the control. Engage the pin on the control linkage into the mating hole in the link attached to the swashplate.
5. With the control in position, move control lever both directions to check proper engagement of control linkage pin. If properly assembled, lever will return to center. If lever does not return to center, remove the control and repeat the above procedure.

MDC removal/installation

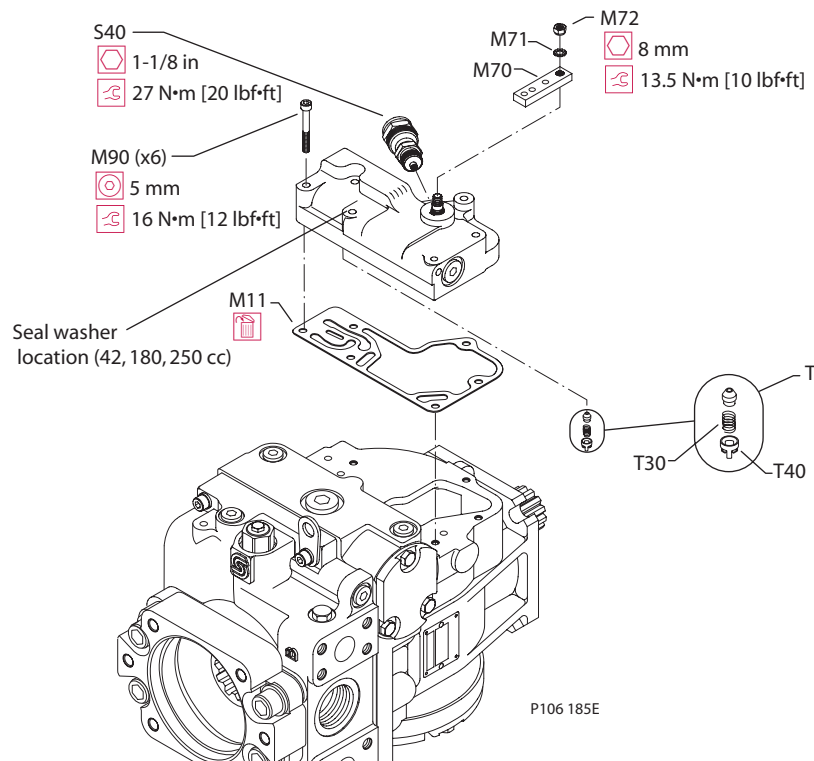



MANUAL DISPLACEMENT CONTROL (MDC) (continued)

If removed, install the control handle (M70) and locking nut (M72) with washer (M71). Hold the position of the handle and torque the locking nut to 13.5 N•m [10 lbf•ft] using an 8mm hex wrench.

6. Align the control gasket and install the screws. Torque the screws to 16 N•m [12 lbf•ft].

Warning

The neutral start switch neutral must be readjusted after reassembling the MDC module.

Install a sealing washer under the head of mounting screws that are installed into through holes in the housing.

7. If the control is equipped with a neutral start switch, refer to *MDC Neutral start switch adjustment* instructions page 41.

SOLENOID OVERRIDE VALVE FOR MDC

Removal

1. Thoroughly clean external surfaces prior to removal of valve.
2. Remove the solenoid from the valve by removing the nut with a 3/4 inch hex wrench. Remove the solenoid valve (M76) from the manifold (M75) with a 7/8 inch hex wrench.
3. Using a 5 mm internal hex wrench, remove the two screws (M78) and remove solenoid manifold (M75) from housing. Remove and discard the gasket (M77).

Reassembly

4. Torque valve (M76) to 24 N•m [17.7 lbf•ft]. Torque solenoid nut to 6 N•m [4.5 lbf•ft]. Do not overtorque the solenoid nut.
5. Install a new gasket on the control housing. Install the manifold onto the control housing, align the gasket, and install the screws. Torque the screws to 13.5 N•m [10 lbf•ft].

Solenoid override valve removal/installation

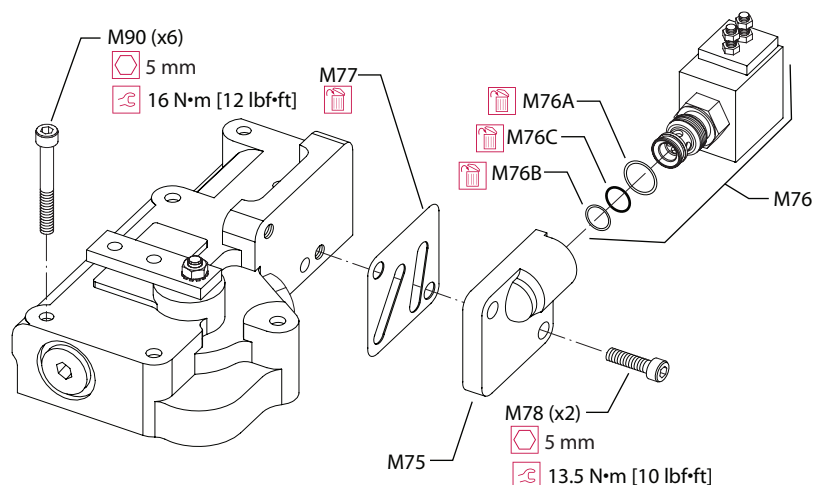

P106 186E



**SOLENOID OVERRIDE
VALVE FOR MDC WITH
PRESSURE RELEASED
BRAKE**

Removal

1. Thoroughly clean external surfaces prior to removal of valve.
2. Using a 4 mm internal hex wrench, remove the four solenoid valve mounting screws (M92). Remove the solenoid valve (M9) (with O-rings) from the adapter plate. Discard the O-rings.
3. Using a 4 mm internal hex wrench, remove the four adapter plate mounting screws (M98). Remove the adapter plate and O-rings (M95, M96, and M97) from the control housing. Discard the O-rings.

Reassembly

4. Using petroleum jelly to retain them, install new O-rings (M96, M96, M97) on the adapter plate. Place the adapter plate into position and install the screws (M98). Torque the screws to 5.4 N•m [4 lbf•ft].
5. Using petroleum jelly to retain them, install new O-rings onto the solenoid valve assembly (M9) and install the solenoid valve onto the adapter plate. Install the screws (M92) and torque to 5.4 N•m [4 lbf•ft].

Solenoid override valve removal/installation

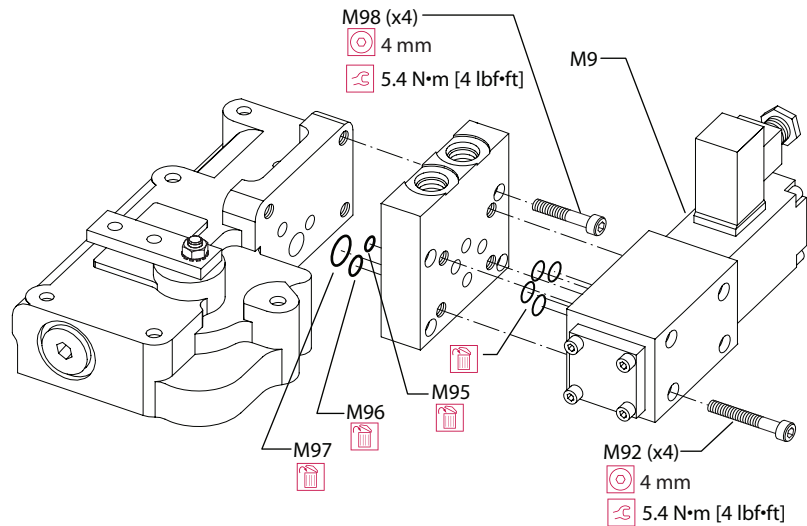

**HYDRAULIC AND
ELECTRIC DISPLACEMENT
CONTROLS**

Removal

1. Thoroughly clean external surfaces prior to removal of control.
2. Using a 5 mm internal hex wrench, remove the six control mounting screws (M90). Remove the control (M1) (with orifice check valve (T40) and spring (T30)) and control gasket (M11) from housing. Discard the gasket.

Caution

Protect exposed surfaces and cavities from damage and foreign material.

Reassembly

3. Install a new gasket (M11). Verify the control orifice check valve and spring (T) are in their proper position in the control.
4. Position the control on the housing. Insert the control linkage pin into the swashplate link.

Hydraulic/Electric displacement control

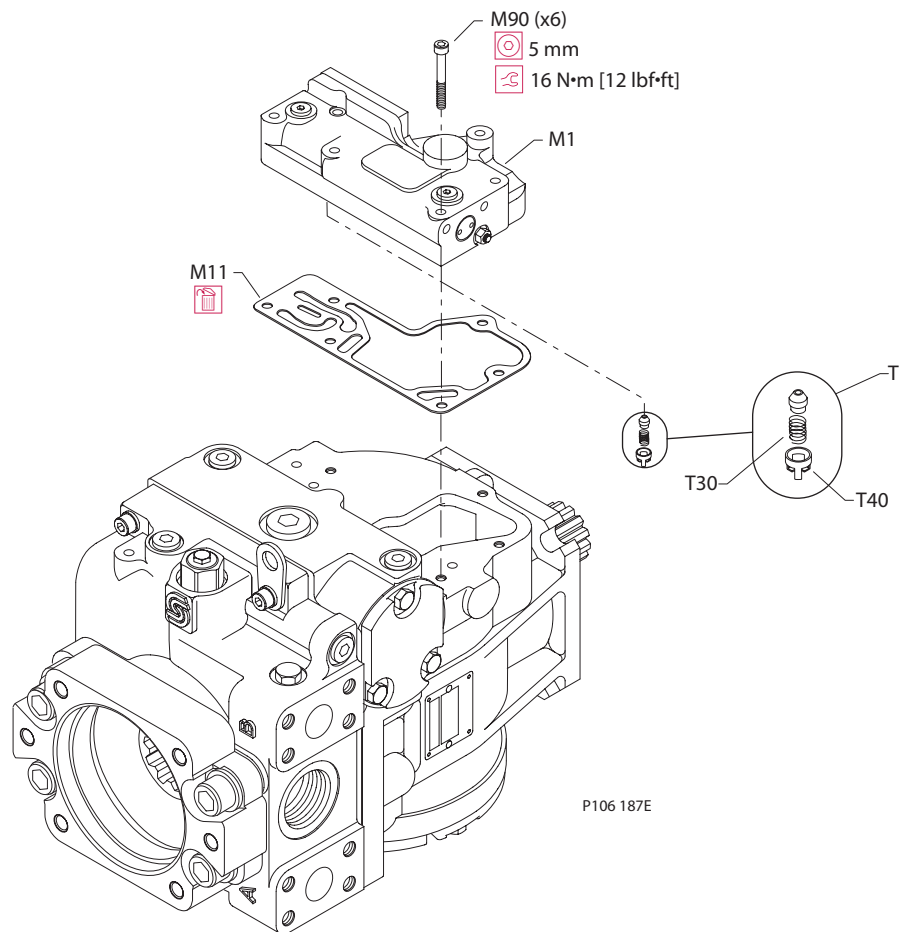



5. With the control in position, move control assembly left and right to check engagement of pin in the link. Proper engagement is indicated by an increasing resistance as the control is moved away from center position. Non-engagement of pin is indicated by lack of spring force. In case of non-engagement, remove control and repeat the above procedure.
6. Align the control gasket and install the screws. Torque the screws to 16 N•m [12 lbf•ft].

Install a sealing washer under the head of any mounting screws that are installed into through holes in the housing.

**PRESSURE CONTROL
 PILOT (PCP) FOR
 ELECTRIC DISPLACEMENT
 CONTROL (EDC)**

Removal

1. Thoroughly clean external surfaces of control.
2. Using a 4 mm internal hex wrench, remove the four screws (M98) and remove the PCP (M9).

Inspection

3. Check surfaces for nicks or damage. Clean internal screens.

Reassembly

4. Install new O-rings (M96 and M97) in PCP Housing. Place PCP against EDC housing and install the screws (M98). Torque to 5.4 N•m [4 lbf•ft].

Do not remove black plastic cover from the aluminum plate. This is not a serviceable item and will void the product warranty.

PCP removal/installation

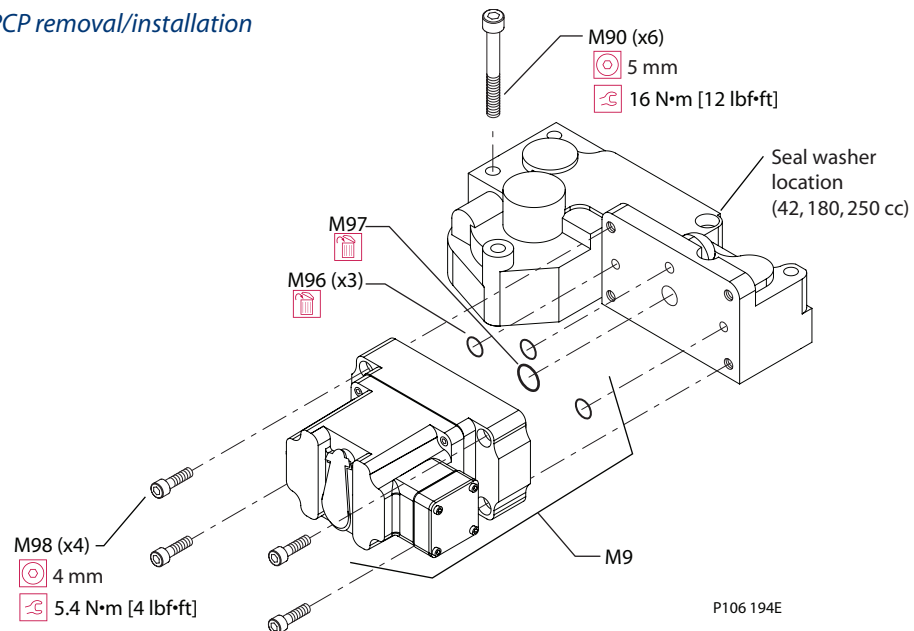

P106 194E

3-POSITION (FNR) ELECTRIC CONTROL

⚠ Caution

Protect exposed surfaces and cavities from damage and foreign material.

Install a sealing washer under the head of any mounting screws that are installed into through holes in the housing.

Removal

1. Thoroughly clean external surfaces prior to removal of control.
2. Using a 4 mm internal hex wrench, remove the four solenoid valve mounting screws (W702). Remove the solenoid valve (W701) (with O-rings (W701A) and orifice) from the adapter plate.
3. Using a 5 mm internal hex wrench, remove the six adapter plate mounting screws (M90). Remove the adapter plate and gasket (M11) from the housing. Discard the gasket. ⚠

Inspection

4. Inspect the orifice installed between the valve and adapter plate. This orifice *must* be installed in the case drain passage for proper pressure limiter operation.

Reassembly

5. Install a new gasket (M11) on the housing. Place the adapter plate into position and install the screws (M90). ⚠ Torque the screws to 16 N•m [12 lbf•ft].
6. Install new O-rings (W701A) and the orifice onto the solenoid valve assembly and install the solenoid valve onto the adapter plate. Install screws (W702). Torque to 5.4 N•m [4 lbf•ft].

FNR removal/installation

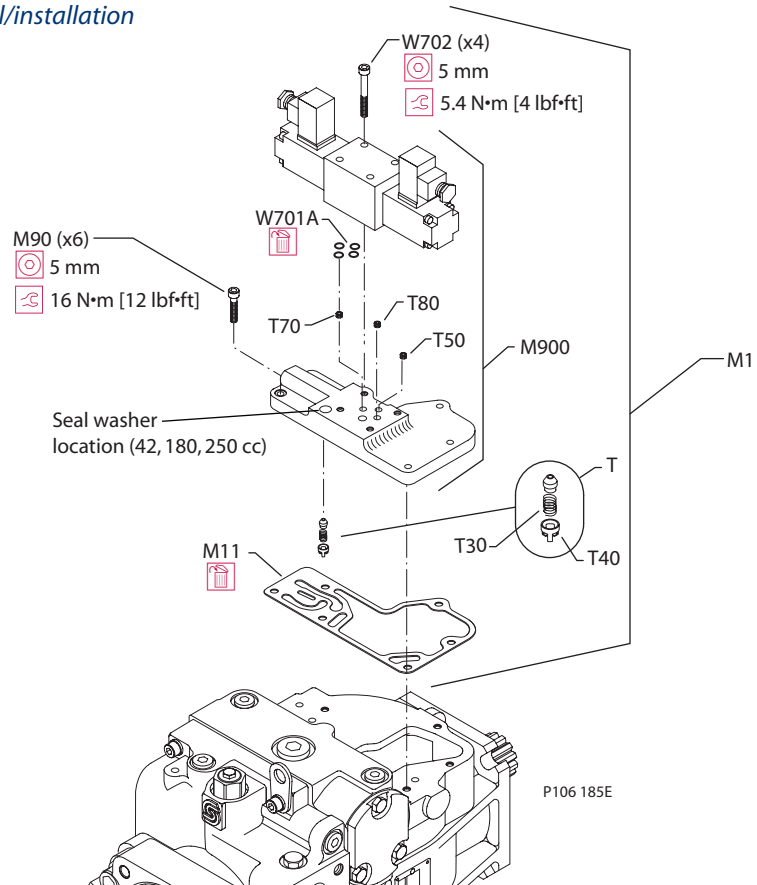



**DISPLACEMENT
 CONTROL FILTER
 SCREENS**

If the pump is equipped with control filter screens in the pump housing (late production), press them into position (with the rounded edge of the filter screens facing the control) until they are flush to 2.0 mm [0.08 inch] below the surface of the housing.

Filter screen installation

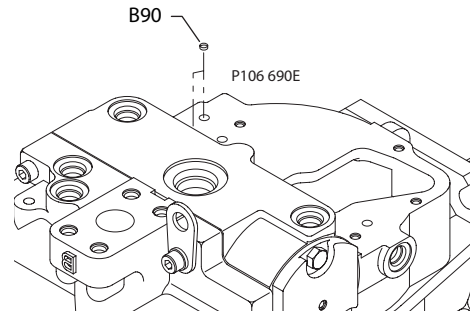

SPEED SENSOR

Removal

1. Loosen the lock nut using a 11/16 in hex wrench.
2. Unscrew the speed sensor (B83) from the pump housing. Remove and discard the O-ring (B83A).

Reassembly

3. Install a new O-ring before reinstalling the sensor.
4. Reinstall the speed sensor (with lock nut and O-ring) into the housing. Adjust the gap between the sensor and the magnetic speed ring as instructed in *Speed sensor adjustment* (page 46) and torque the sensor lock nut to 13 N•m [10 lbf•ft].
5. If a speed sensor is not installed, use a 1/4 in internal hex wrench to torque the housing plug (B83) to 40 N•m [30 lbf•ft].

Typical location of speed sensor

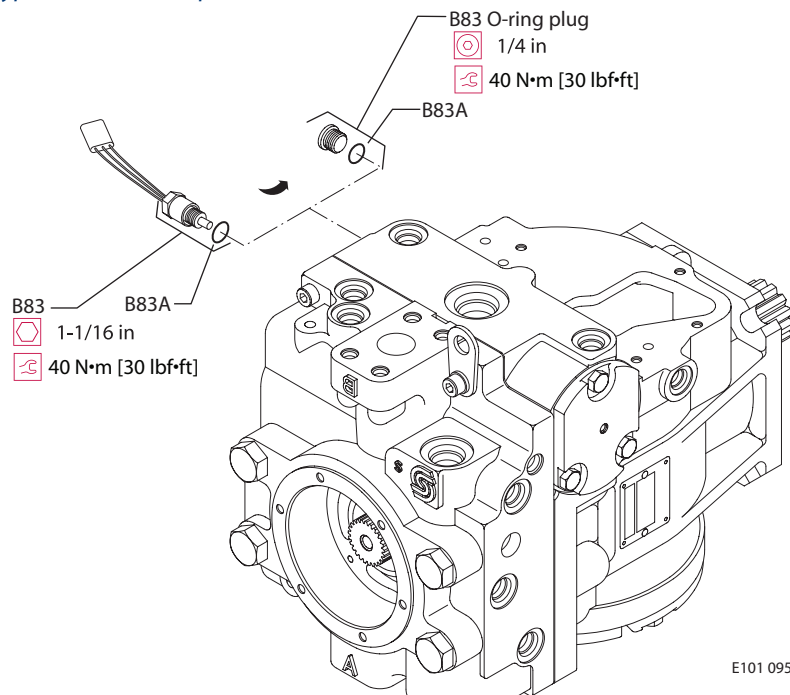

E101 095E

Series 90 Axial Piston Closed Circuit Pumps Service Manual Torque chart



FASTENER SIZE AND TORQUE CHART

Item	Fastener	Frame size	Wrench size	Torque
B83	Speed sensor lock nut	030-250	1-1/16 in hex	13.5 N•m [10 lbf•ft]
E60	Side cover screw Blind holes	030-042	10 mm hex	13.5 N•m [10 lbf•ft]
		055-100	13 mm hex	32 N•m [24 lbf•ft]
		130-250	17 mm hex	64 N•m [37 lbf•ft]
E60	Side cover screw Thru holes	030-042	10 mm hex	10.4 N•m [7.7 lbf•ft]
		055-100	13 mm hex	32 N•m [24 lbf•ft]
		130-250	17 mm hex	32 N•m [47 lbf•ft]
F111/ F211	Servo cylinder screw	030-055	8 mm hex	13.5 N•m [10 lbf•ft]
		075-250	10 mm hex	32.5 N•m [24 lbf•ft]
G90/ G97	End cap screw	030-042	5 mm internal hex	13.5 N•m [10 lbf•ft]
		055-100	6 mm internal hex	32.4 N•m [24 lbf•ft]
		130	10 mm hex	38 N•m [28 lbf•ft]
		180-250	10 mm hex	110 N•m [81 lbf•ft]
H80	Charge pump retaining screw	030-100	10 mm hex	16 N•m [11.85 lbf•ft]
		130-250	13 mm hex	32 N•m [24 lbf•ft]
J80	End cap screw	030	8 mm internal hex	58 N•m [43 lbf•ft]
		early 042	8 mm internal hex	75 N•m [55 lbf•ft]
		late 042	10 mm internal hex	75 N•m [55 lbf•ft]
		055	19 mm hex	122 N•m [90 lbf•ft]
		075-100	24 mm hex	298 N•m [220 lbf•ft]
		100-130	14 mm internal hex	298 N•m [220 lbf•ft]
		180-250	17 mm internal hex	580 N•m [429 lbf•ft]
K10	Charge pressure valve plug	030-250	1/2 in hex	NA
K90	Charge pressure lock nut	030-100	1-1/16 in hex	52 N•m [38 lbf•ft]
		130-250	1-5/8 in hex	52 N•m [38 lbf•ft]
L70	Shaft retaining screw	030-042	10 mm hex	12 N•m [9 lbf•ft]
		055-100	5 mm internal hex	16 N•m [12 lbf•ft]
		130-250	6 mm internal hex	32 N•m [24 lbf•ft]
M72	MDC handle nut	030-250	8 mm	13.5 N•m [10 lbf•ft]
M78	De-stroke valve manifold screw	030-250	5 mm internal hex	13.5 N•m [10 lbf•ft]
M85	Eccentric plug lock nut	030-250	1-1/8 in hex	27 N•m [20 lbf•ft]
M88	Neutral start switch lock nut	030-250	1-1/8 in hex	27 N•m [20 lbf•ft]
M90	Control mounting screw	030-250	5 mm internal hex	16 N•m [12 lbf•ft]
M92	Solenoid valve mounting screw	030-250	4 mm internal hex	5.4 N•m [4 lbf•ft]
M98	PCP mounting screw	030-250	4 mm internal hex	5.4 N•m [4 lbf•ft]
N10	Filter reducer assembly	030-042	1-1/4 in hex	70 N•m [52 lbf•ft]
		055-130	1-1/2 in hex	122 N•m [90 lbf•ft]
		180-250	1-1/2 in hex	156 N•m [115 lbf•ft]
N37	Filter plug assembly	030-250	1/4 in internal hex	27 N•m [20 lbf•ft]
P2B1/ P2A1	Multi-function valve	030-100	1-1/4 in hex	89 N•m [66 lbf•ft]
		130-250	1-5/8 in hex	210 N•m [155 lbf•ft]

Series 90 Axial Piston Closed Circuit Pumps

Service Manual

Torque chart



PLUG SIZE AND TORQUE CHART

If any plugs or fittings are removed from the pump during servicing, install and torque as indicated in the accompanying table. **!**

! Caution

Torque plugs or fittings installed into aluminum housings to the lower values specified for internal hex plugs of the same size.

Always install new O-rings before reinstalling the plugs or fittings.

Item	O-ring plug	Wrench size	Torque
B70, B72	9/16-18	3/16 internal hex wrench	40 N•m [30 lbf•ft]
B71	9/16-18	3/16 internal hex wrench	12 N•m [9 lbf•ft]
B80	1-1/16-12	9/16 internal hex wrench	115 N•m [85 lbf•ft]
B82, B83	9/16-18	1/4 internal hex wrench	40 N•m [30 lbf•ft]
G18	7/16-20	3/16 internal hex wrench	12 N•m [9 lbf•ft]
G45-G50	9/16-18	11/16 inch hex wrench	40 N•m [30 lbf•ft]
G52-G54	9/16-18	1/4 internal hex wrench	23 N•m [17 lbf•ft]
H90 (not shown)	1-5/16-12	5/8 internal hex wrench	129 N•m [95 lbf•ft]
N35, N36 (not shown)	9/16-18	11/16 inch hex wrench	37 N•m [27 lbf•ft]
N37	9/16-18	1/4 internal hex wrench	40 N•m [30 lbf•ft]

FASTENERS AND PLUGS

Fastener and plug locations

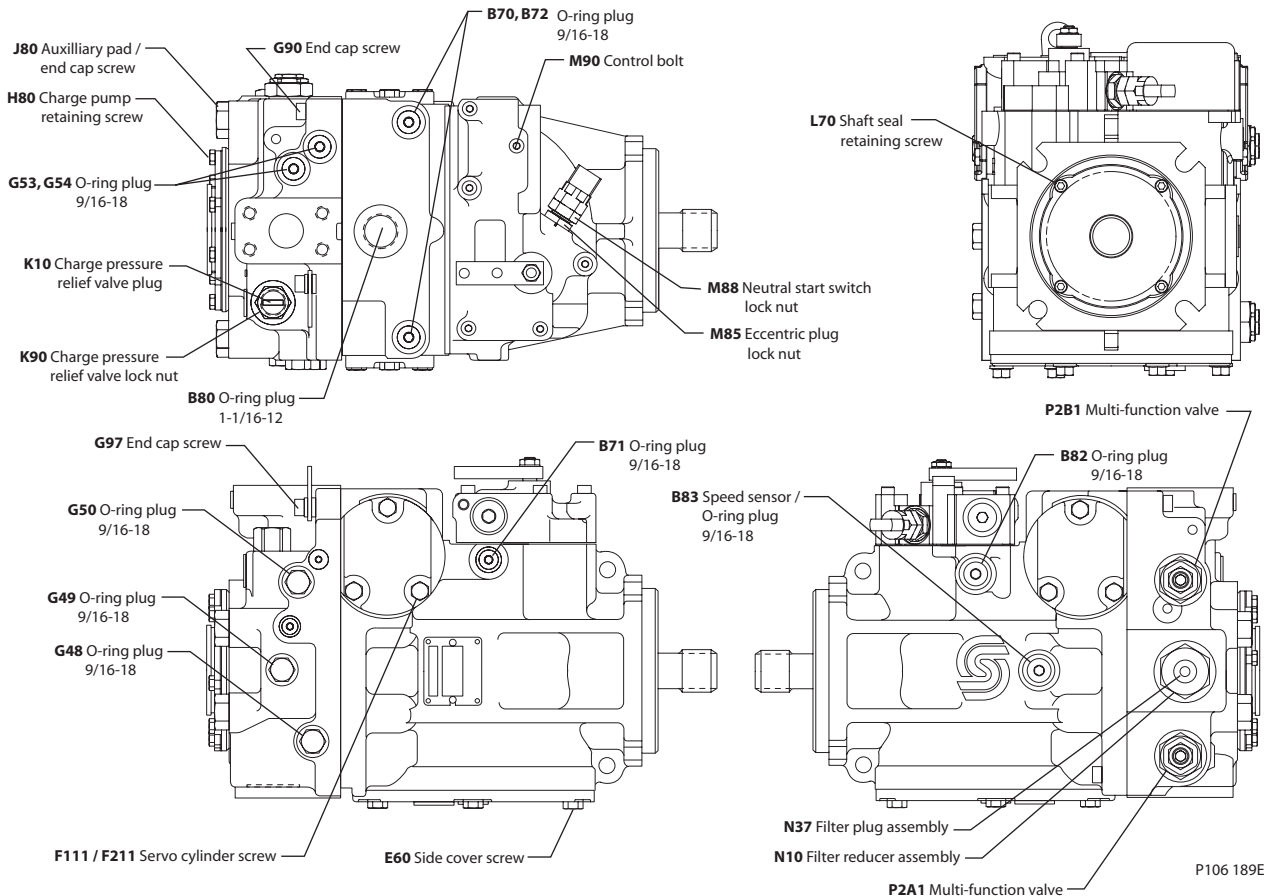

 www.khadamathydraulic.com
Tell: 021-55882749
Tell: 021-33488178
Fax: 021-33488105

Series 90 Axial Piston Closed Circuit Pumps Service Manual

Notes



Products we offer:

- Bent Axis Motors
- Closed Circuit Axial Piston Pumps and Motors
- Displays
- Electrohydraulic Power Steering
- Electrohydraulics
- Hydraulic Power Steering
- Integrated Systems
- Joysticks and Control Handles
- Microcontrollers and Software
- Open Circuit Axial Piston Pumps
- Orbital Motors
- PLUS+1™ GUIDE
- Proportional Valves
- Sensors
- Steering
- Transit Mixer Drives

Members of the Sauer-Danfoss Group:

Comatrol

www.comatrol.com

Schwarz Müller-Inverter

www.schwarzmueller-inverter.com

Turolla

www.turollaocg.com

Hydro-Gear

www.hydro-gear.com

Sauer-Danfoss-Daikin

www.sauer-danfoss-daikin.com

Sauer-Danfoss is a global manufacturer and supplier of high-quality hydraulic and electronic components. We specialize in providing state-of-the-art technology and solutions that excel in the harsh operating conditions of the mobile off-highway market. Building on our extensive applications expertise, we work closely with our customers to ensure exceptional performance for a broad range of off-highway vehicles.

We help OEMs around the world speed up system development, reduce costs and bring vehicles to market faster.

Sauer-Danfoss – Your Strongest Partner in Mobile Hydraulics.

Go to www.sauer-danfoss.com for further product information.

Wherever off-highway vehicles are at work, so is Sauer-Danfoss.

We offer expert worldwide support for our customers, ensuring the best possible solutions for outstanding performance. And with an extensive network of Global Service Partners, we also provide comprehensive global service for all of our components.

Please contact the Sauer-Danfoss representative nearest you.

Local address:

Sauer-Danfoss (US) Company
2800 East 13th Street
Ames, IA 50010, USA
Phone: +1 515 239 6000
Fax: +1 515 239 6618

Sauer-Danfoss ApS
DK-6430 Nordborg, Denmark
Phone: +45 7488 4444
Fax: +45 7488 4400

Sauer-Danfoss GmbH & Co. OHG
Postfach 2460, D-24531 Neumünster
Krokamp 35, D-24539 Neumünster, Germany
Phone: +49 4321 871 0
Fax: +49 4321 871 122

Sauer-Danfoss-Daikin LTD.
Shin-Osaka TERASAKI 3rd Bldg. 6F
1-5-28 Nishimiyahara, Yodogawa-ku
Osaka 532-0004, Japan
Phone: +81 6 6395 6066
Fax: +81 6 6395 8585