

220 Piston Pump Service Manual

 www.khadamathydraulic.com
Tell: 021-55882749
Tell: 021-33488178
Fax: 021-33488105

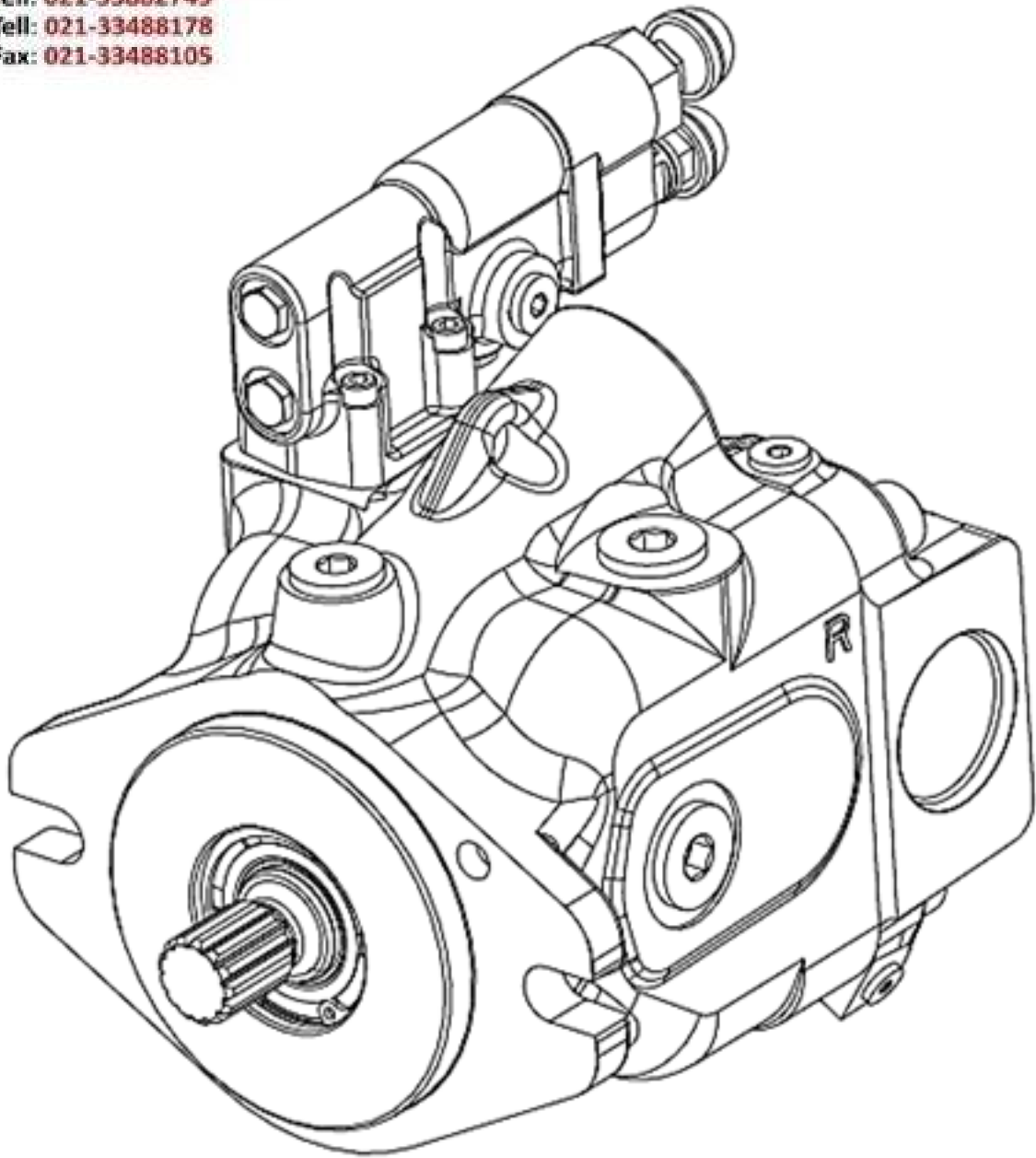

EATON

Powering Business Worldwide

 www.khadamahydraulic.com
Tell: 021-55882749
Tell: 021-33488178
Fax: 021-33488105

Table of Contents

 www.khadamathydraulic.com
Tell: 021-55882749
Tell: 021-33488178
Fax: 021-33488105

Part Identification	4
Exploded Assembly	5
Optional Assembly.....	6
Typical Cross Section.....	7
Shaft, Drive and Key	8
End Cover S/A	9
Valve Plate	10
Housing	11
Rotating Group	11
Swash Plate.....	11
Shaft Seal.....	11
Compensator	12
Compensator Mounting Screws.....	12
Plug Subassemblies	12
Pump Repair	13
Inspection, Repair and Part Replacement.....	17
Assembly.....	20
Assembly Torque Values	23

Part Identification - 220 Series Pumps

Item	Part Number	Quantity	Description	Page Number
1	See table 1	1	Shaft, Drive ●	
2	6028118-XXX	AR	Spacer, Bearing / Bearing Shim Kit *****_*** ●	
3	See table 1	1	Key, Driveshaft	
4	See Table 2	1	End Cover S/A ●	
5	16026-610	1	Roll Pin	
6	See table 3	1	Valve Plate	
7	104166-156	1	O-Ring ◆	
8	See table 4	1	Housing ●	
9	388153	1	Bearing Assembly, Shaft (Front) ●	
10	02-335336	1	Bearing Assembly, Shaft (Rear) ●	
11	6026924-001	2	Bearing, Swash Plate / Bearing Kit *****_***	
12	114995-010	2	Screw, Cap, Socket / Bearing Kit *****_***	
13	5992034-001	1	Spring, Bias	
14	See table 6	1	Swash Plate	
15	See table 5	1	Rotating Group S/A	
16	114977-035	4	Screw, Cap (Housing / End cover)	
17	16253-218	1	Seal, Shaft, Fluorocarbon ◆	
18	16077-032	1	Ring, Retaining, Internal (Shaft Seal)	
19	See Table 8	1	Compensator Kit	
20	107275-011	4	O-Ring (Secondary Compensator / Housing) ◆	
21	107275-017	1	O-Ring (Compensator / Housing) ◆	
22	See Table 9	4	Screw, Cap (Compensator Mounting)	
23	6030097-001	1	Piston, Control	
24	6030098-001	1	Plug, Adjustable Volume Stop □	
25	16103-302	3	Plug	
26	See table 10	3	Plug S/A	
27	See table 10	1	Plug (Top Case Drain Port)	
28	See table 10	1	Plug (Diagnostic Port)	
29	6026914-001	1	Link, Feedback	
30	114995-010	1	Screw, Cap, Socket, Flat, Countersunk	
31	5990203-001	1	Magnet Carrier	
32	54999158	1	Adapter, Swash Sensor	
33	104166-021	1	O-Ring (Adapter / Swash Sensor Assy.) ◆	
34	6024371-002	1	Feedback Sensor, Non-Contact	
35	6027085-001	2	Screw, Cap S/A (Swash Sensor)	
36	16026-406	1	Pin, Roll (Feedback Link)	
37	6030096-350	1	Screw, Cap □	
38	692866	1	Nut Sealing □	
39	16133-12	1	O-Ring □	
40	937166	2	Tamper Proof Cap	

● Standard Seal Kit : *****

◆ Adjustable Maximum Displacement Volume Stop Kit : *****

□ Shaft bearing Shim Kit : *****

Exploded Assembly - 220 Series Pump

Part Item Number

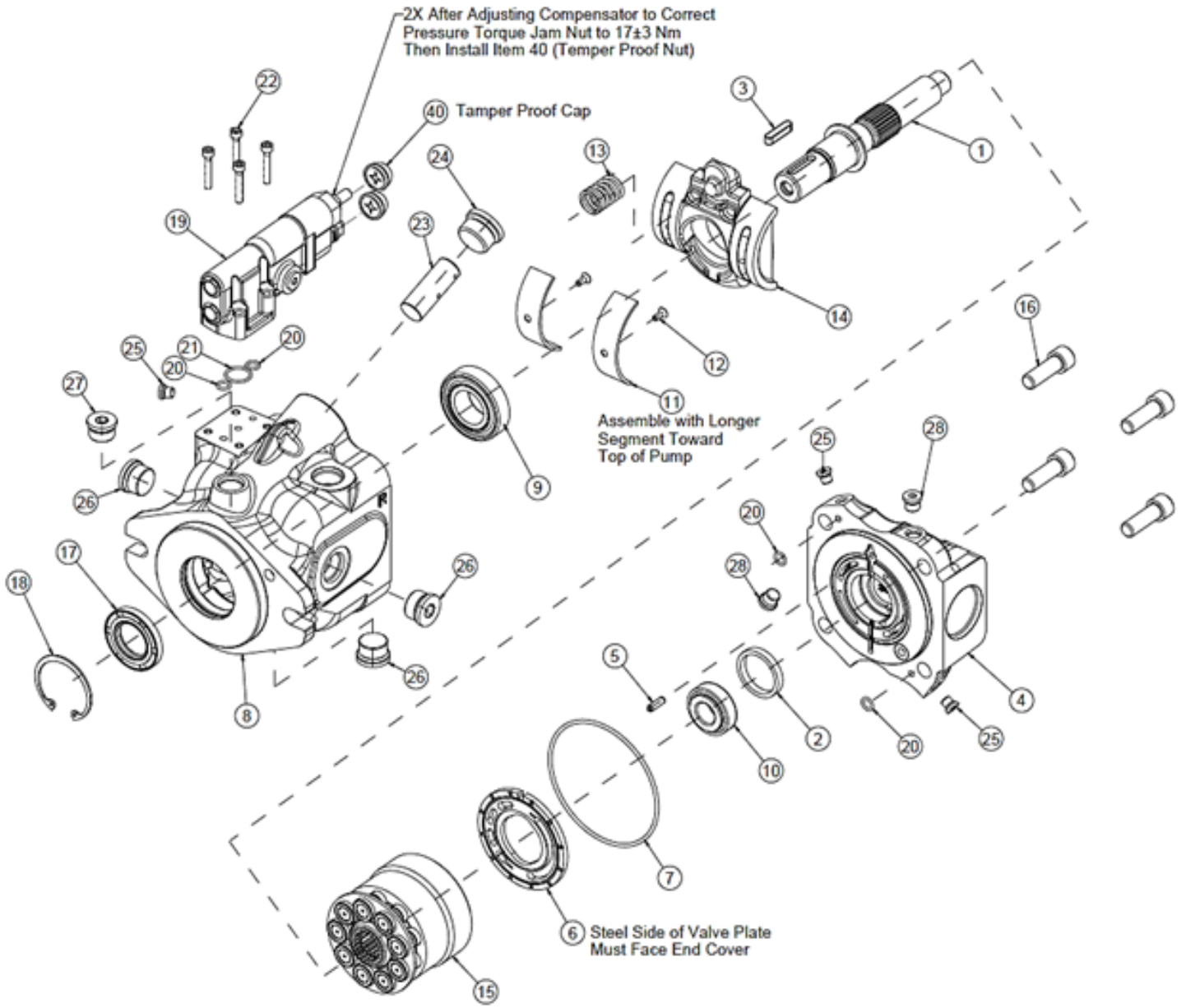

Optional Assembly - 220 Series Pumps

Part Item Number

Feedback Sensor Option

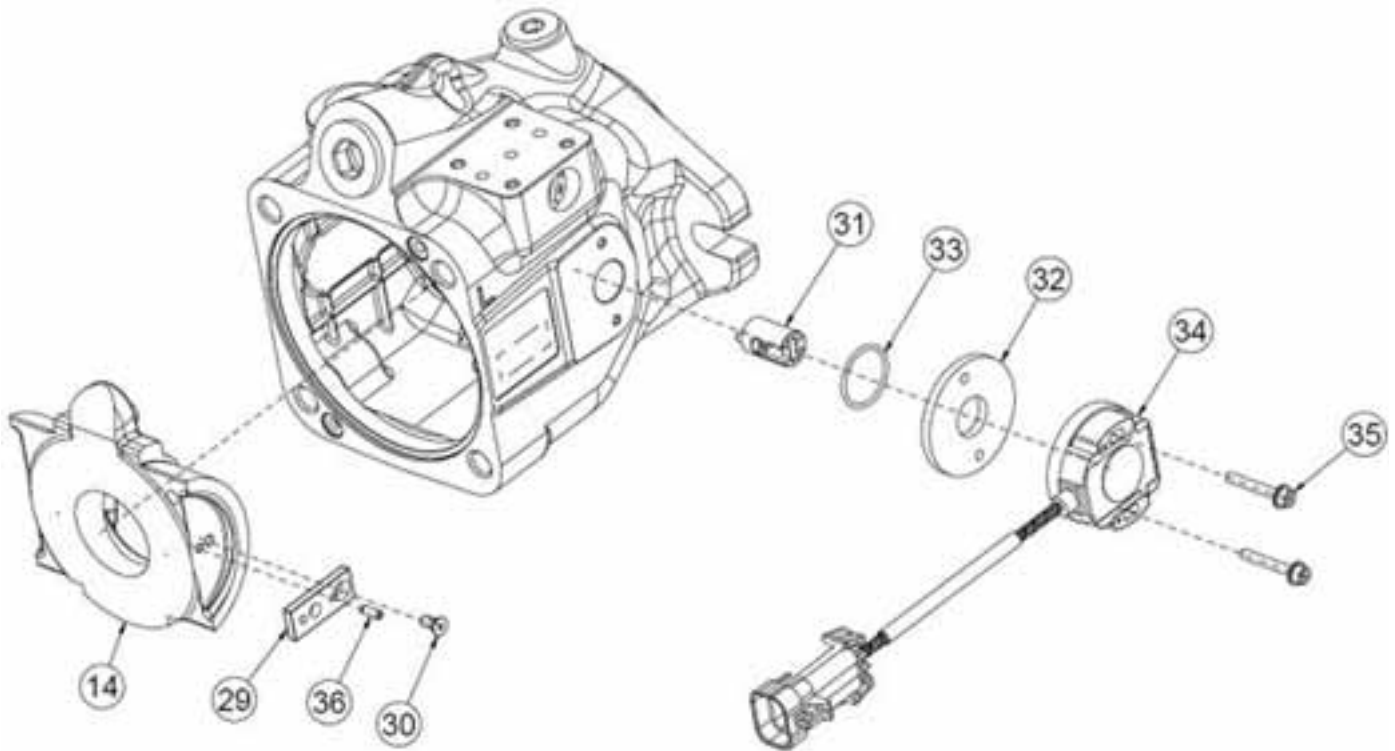

Adjustable Maximum Stop Option

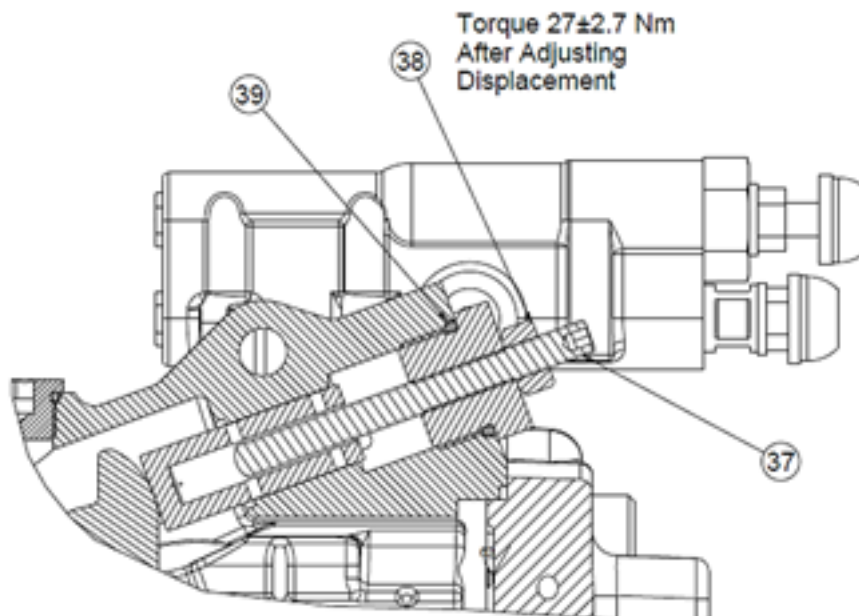

Typical Cross Section - 220 Series Pumps

Side View

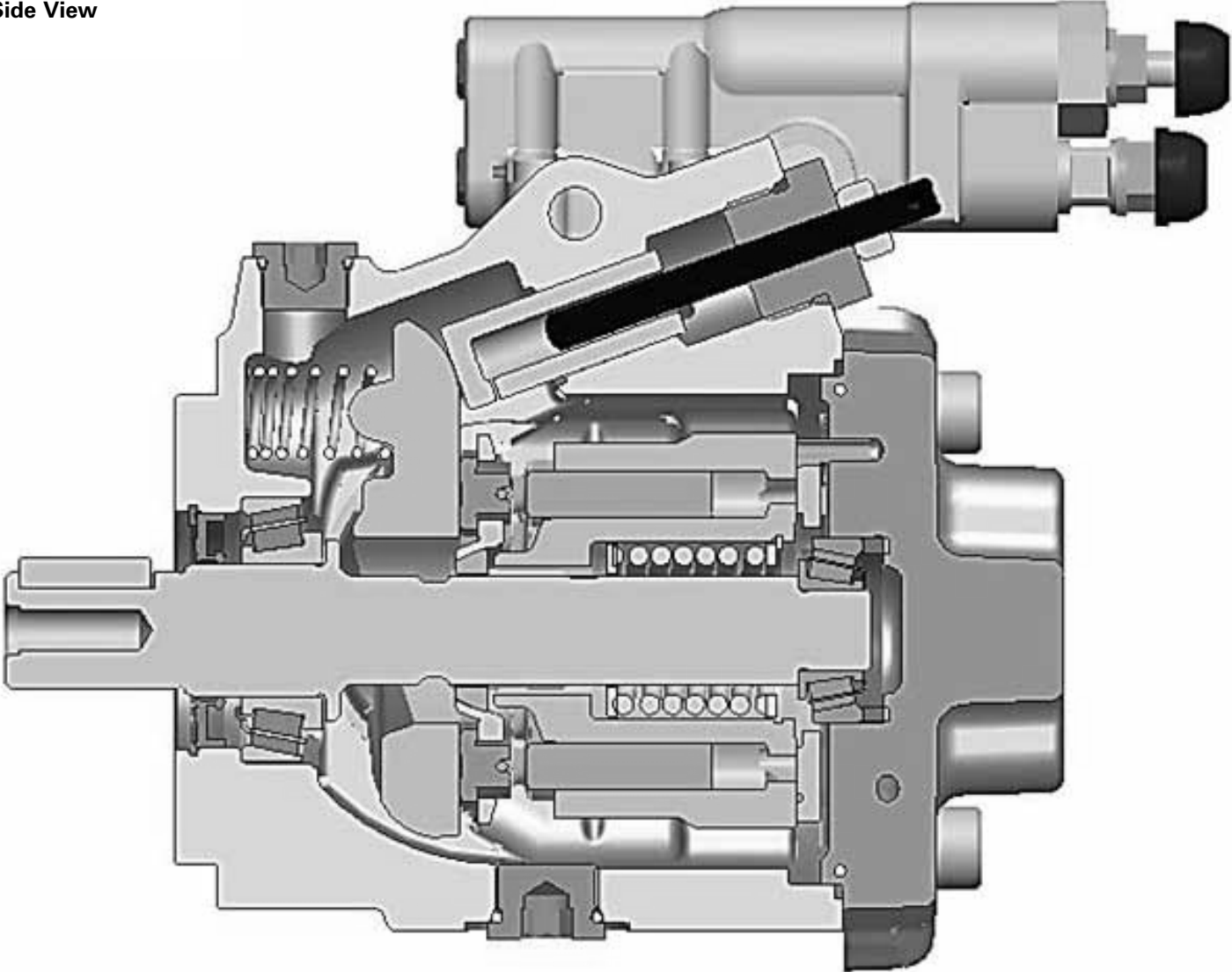

Shaft, Drive and Key - Item 1 & 3

Table 1

Table 1 - Shaft, Drive and Key (Items 1 & 3)

Code	Position				
4,5,6	8,9	24,25	Key (Item 3)	Part Number	Description
028	05	00	24500-619	6026704-003	Shaft, Drive, 22.2 Dia. Straight Key, 41 mm Ext.
028	09	00	-	6026704-001	Shaft, Drive, Input 13 Tooth 16/32, 41 mm Ext.
028	31	00	16246-516	6026704-002	Shaft, Drive, 25.4 Dia. Straight Key, 46 mm Ext.
028	34	00	-	6026704-004	Shaft, Drive, Input 15 Tooth 16/32, 46 mm Ext.

220 Series Mobile Piston Pump Drive Shaft

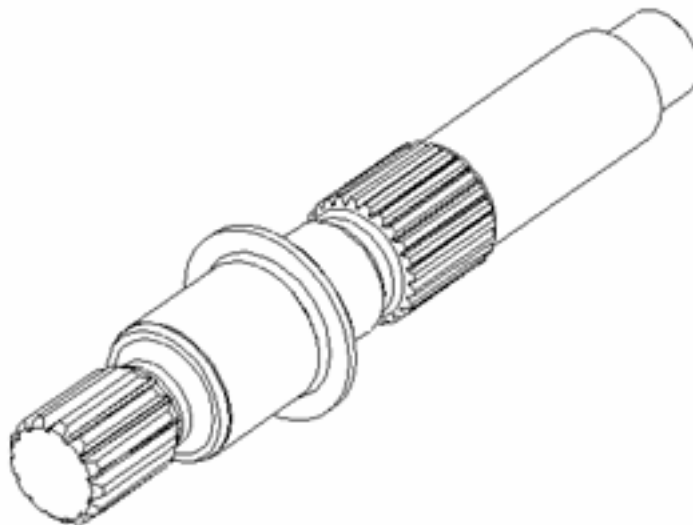

End Cover S/A - Item 4

Table 2

Table 2 - End Cover S/A (Item 4)

Code	Position	4,5,6	7	10,11	13	24,25	Part Number	Description
028	L,R	AA	1	00			6026786-002	End Cover S/A, Rear Port 28 cc (O-ring Port)
028	L,R	AB	1	00			6026786-001	End Cover S/A, Side Port 28 cc (O-ring Port)
028	L,R	AC	2	00			6026786-006	End Cover S/A, Rear Port 28 cc Metric
028	L,R	AD	2	00			6026786-005	End Cover S/A, Side Port 28 cc Metric
028	L,R	AE	1	00			6026786-004	End Cover S/A, Rear Port 28 cc (4 Bolt Flange Port)
028	L,R	AF	1	00			6026786-003	End Cover S/A, Side Port 28 cc (4 Bolt Flange Port)

220 Series Mobile Piston Pump End Cover views

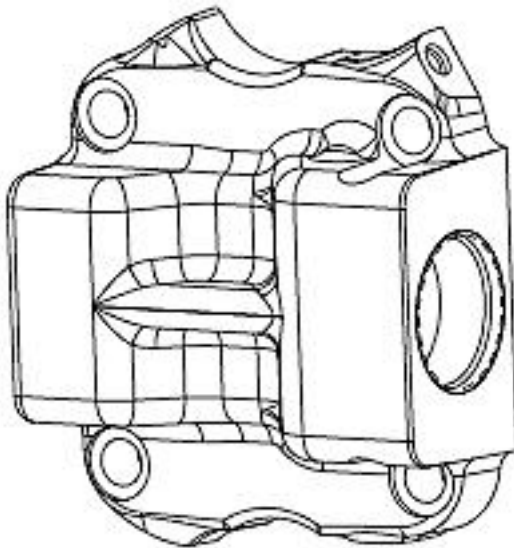

Side Port

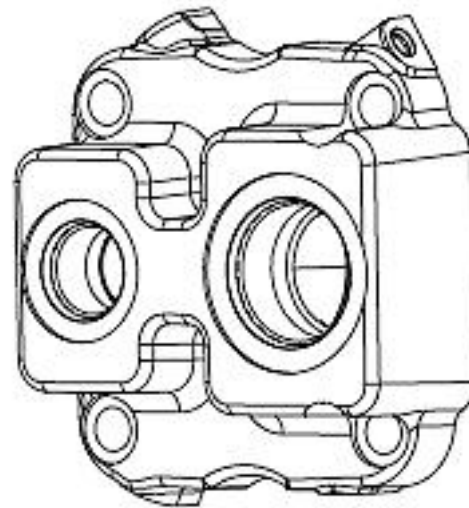

Rear Port

Valve Plate - Item 6

Table 3

Table 3 - Valve Plate (Item 6)

Code 4,5,6	Position 7	Part Number	Description
028	R	6029630-001	Plate, Valve (RH 28 cc)
028	L	6029630-002	Plate, Valve (LH 28 cc)

220 Series Mobile Piston Pump Valve Plate Identification

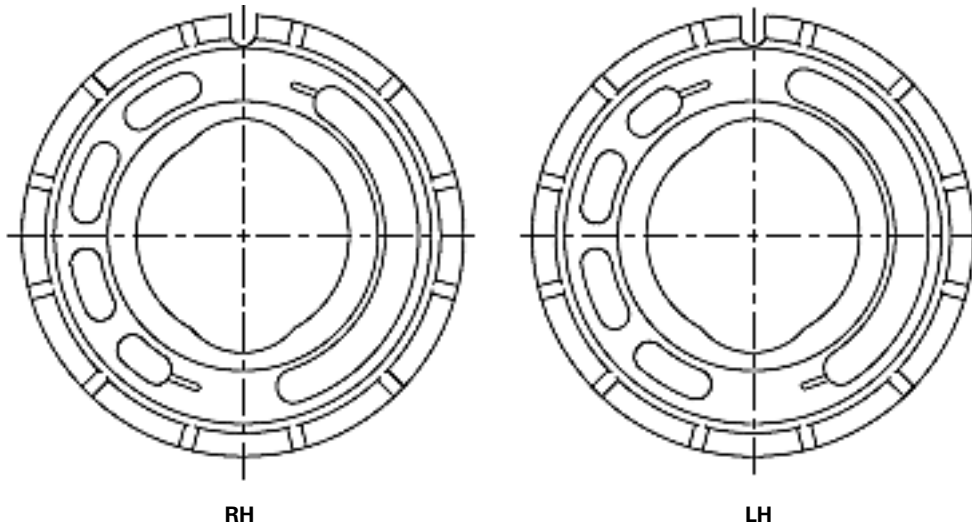

Housing - Item 8
 Rotating Groups - Item 15
 Swash Plate - Item 14
 Shaft Seal - Item 17

Tables 4, 5, 6 & 7

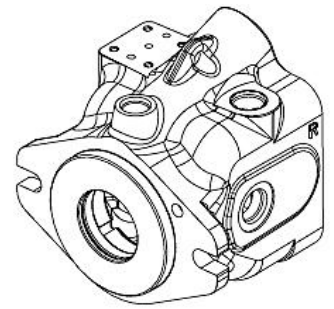

Table 4 - Housing (Item 8)

Code Position 8,9	12	27,28	Part Number	Description
05,09,31,34	A,B,G	AB	6026919-001	Housing (Feedback Sensor)
05,09,31,34	A,B,E,G	00	6026919-002	Housing
05,09,31,34	C,D,F,H	00	6026919-003	Housing Metric Drain Port

Table 5 - Rotating Group (Item 15)

Code Position 4,5,6	Part Number	Description
028	6026982-001	Rotating Group S/A (28 cc)

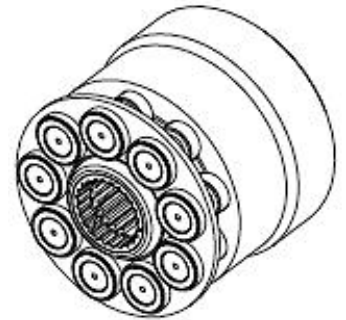

Table 6 - Swash Plate (Item 14)

Code Position 4,5,6	Part Number	Description
028	6026917-001	Swash Plate (28 cc)



**220 Series Mobile Piston Pump
 Swash Plate View**

Table 7 - Shaft Seal (Item 17)

Code Position 4,5,6	Part Number	Description
1	16253-218	Seal, Shaft, Fluorocarbon



**220 Series Mobile Piston Pump
 Shaft Seal View**

Compensator - Item 19,20,21,22 & 40

Compensator Mounting Screws - Item 22

Plug Subassemblies - Item 26, 27 & 28

Table 8, 9 & 10

Table 8 - Compensator (Items 19,20,21,22 & 40)

Control Code 14	Code 15,16	Pressure Limit Setting	Code 17,18	Flow Setting	Code 21,22	Kit Number
A	43	275.8-282.7 bar [4000-4100 lbf/in ²]	14	12.4-15.2 bar [180-220 lbf/in ²]	0A	Have to allocate
A	32	226.5-233.4 bar [3285-3385 lbf/in ²]	14	12.4-15.2 bar [180-220 lbf/in ²]	00	Have to allocate
A	28	206.8-213.7 bar [3000-3100 lbf/in ²]	10	9.7-12.4 bar [140-180 lbf/in ²]	0A	Have to allocate
A	28	206.8-213.7 bar [3000-3100 lbf/in ²]	14	12.4-15.2 bar [180-220 lbf/in ²]	00	Have to allocate
A	28	206.8-213.7 bar [3000-3100 lbf/in ²]	20	17.2-20.0 bar [250-290 lbf/in ²]	00	Have to allocate
A	22	182.7-189.6 bar [2650-2750 lbf/in ²]	10	9.7-12.4 bar [140-180 lbf/in ²]	00	Have to allocate
A	15	151.7-158.6 bar [2200-2300 lbf/in ²]	17	15.9-18.6 bar [230-270 lbf/in ²]	0A	Have to allocate
A	13	144.8-151.7 bar [2100-2200 lbf/in ²]	20	17.2-20.0 bar [250-290 lbf/in ²]	00	Have to allocate
B	24	189.6-196.5 bar [2750-2850 lbf/in ²]	20	17.2-20.0 bar [250-290 lbf/in ²]	00	Have to allocate
C	28	206.8-213.7 bar [3000-3100 lbf/in ²]	00	-	00	Have to allocate

**220 Series Mobile Piston Pump
Compensator views**

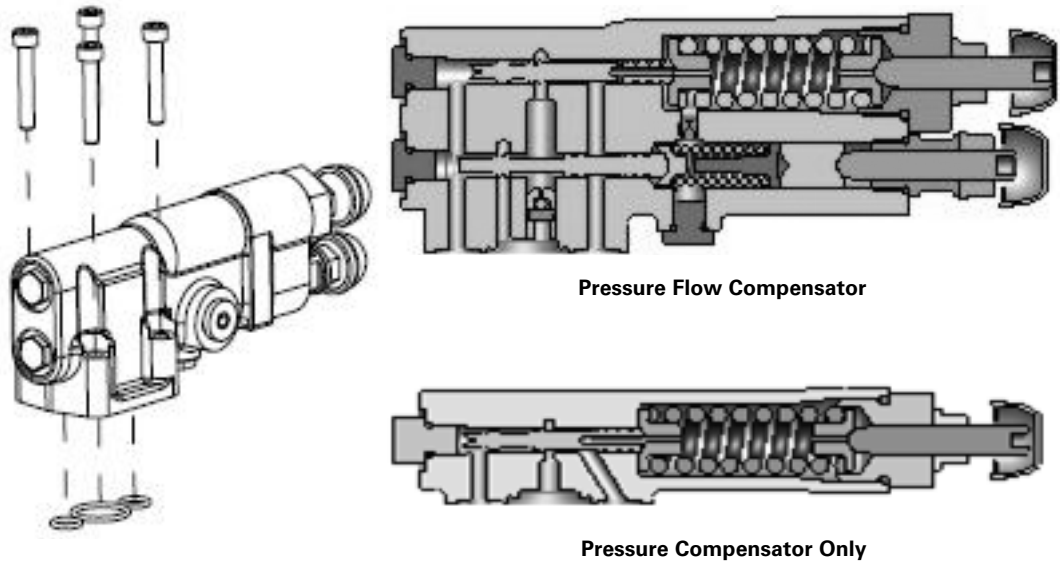

Table 9 - Compensator Mounting Screw (Item 22)

Code Position 21,22	Part Number	Description
00,0A	114953-030	Screw, Cap (Compensator Mounting)

Table 10 - Plug Subassemblies (Items 26, 27 & 28)

Code Position 12	13	27,28	Part Number	Description
A,B,E,G	-	00,AB	16103-310	Plug (Bottom, Side and Top Case Drain) .875-14 UNF-2B Thd.
C,D,F	-	00,AB	9237-005	Plug (Bottom, Side and Top Case Drain) M22 X 1.5 Thd.
A,B,E	-	-	16103-308	Plug (Vertical Case Drain) .750-16 UNF-2B Thd.
C,D,F	-	-	9237-004	Plug (Vertical Case Drain) M18 X 1.5 Thd.
-	1	-	16103-304	Plug (Diagnostic Ports) .4375-20 UNF-2B Thd.
-	2	-	9237-002	Plug (Diagnostic Ports) M12 X 1.5 Thd.

Pump Repair

Cut Section

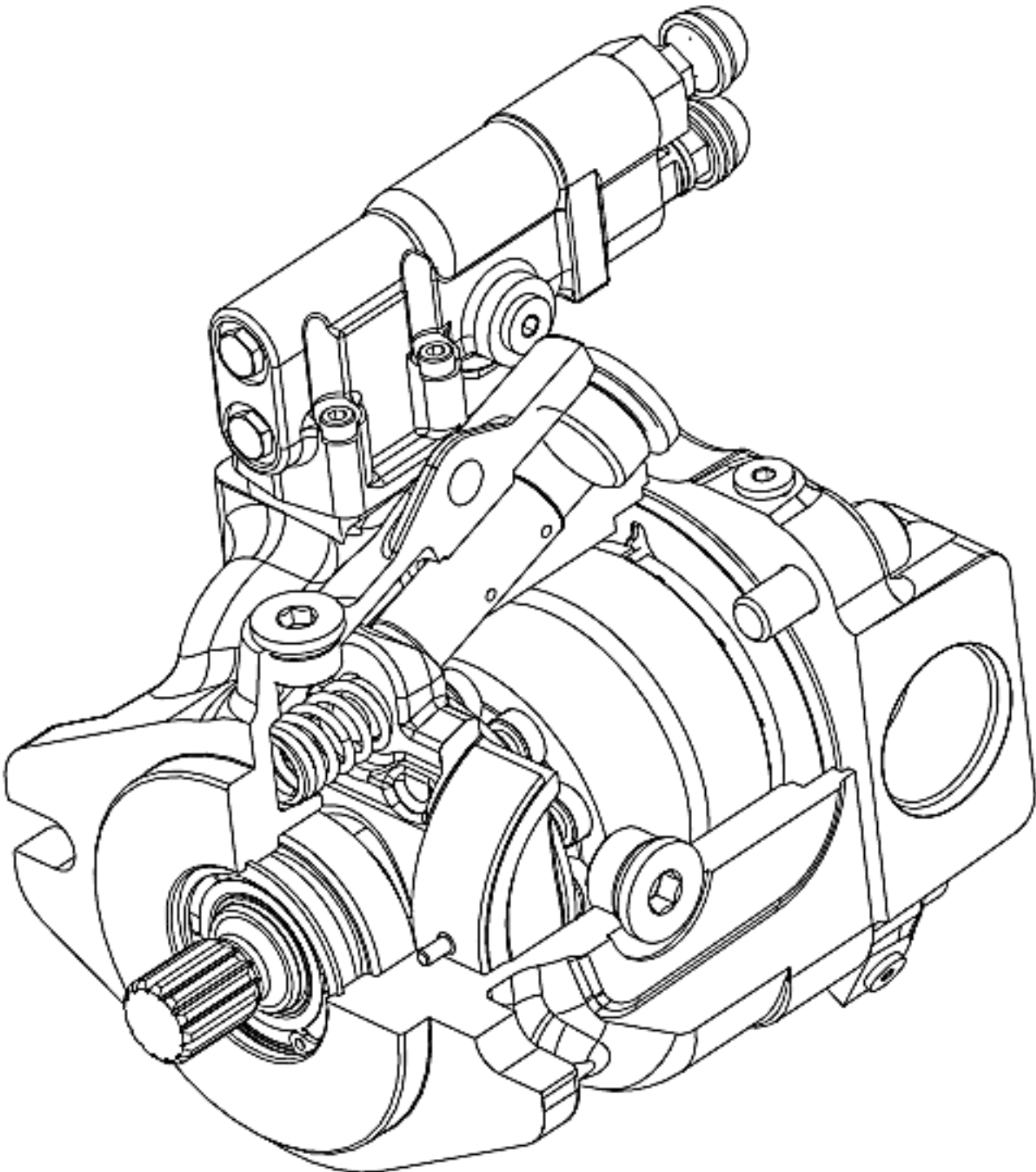

Pump Repair

Cut Section

1. Remove Control Piston Plug Assembly



2. Install Swash Plate Locator Tool Adjustment will take place in step 11.



3. Remove Compensator



4. Remove End Cover Mark the housing and end cover to ensure orientation. Remove the four cap screws that hold the end cover in place. Note: The valve plate may stick to end cover. Use caution so valve plate does not fall off.



5. Remove O-ring Seal



6. Remove Valve Plate



7. Remove Bearing Race The bearing race is pressed in and will require the use of a sliding bearing removal hammer or similar tool to remove it.



8. Remove Bearing



Pump Repair

Cont.

9. Remove Housing O-rings



11. Swashplate Adjustment Locator With the hold down tool in place, tighten the adjustment screw so the control piston spring is compressed. **Note:** This step is designed to force the swashplate to a neutral position to enable easy removal of the rotating group, and to retain the swashplate.



13. Remove Rotating Group



15. Remove Swashplate Locator



10. Install Swashplate Retainer Install the swash plate hold down tool and tighten the cap screw. This will prevent the swash plate from moving.



12. Install Shaft Retainer Tool Tighten the set screw while being careful not to damage shaft.



14. Remove Shaft Remove shaft retainer tool and lift out shaft. Use caution when moving shaft through shaft seal.



16. Remove Swashplate Retainer



Pump Repair

Cont.

17. Remove Control Piston



18. Remove Swashplate



19. Remove Bias Spring

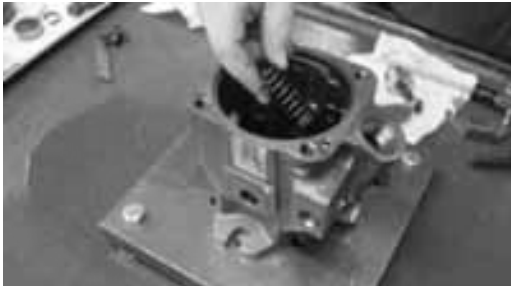

20. Remove Bearing

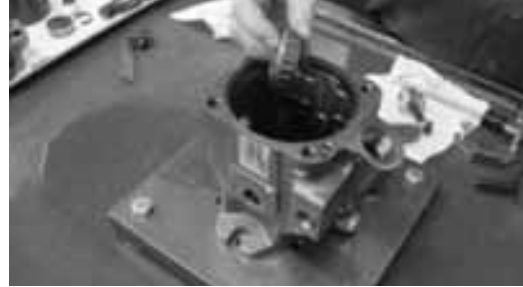

21. Remove Cradle Bearing Screws Caution: Socket head cap screws are easily damaged during repair with improper tool.



22. Remove Cradle Bearings Note: The cradle bearings are asymmetrical. Note proper orientation shown in picture.



23. Remove Front Bearing Race



24. Remove Shaft Seal With the seal retaining ring removed use a punch or similar tool to knock out the shaft seal.



Inspection, Repair and Part Replacement

Inspection

Inspection

Before inspection of parts, clean with a solvent that is compatible with system fluid.

Rotating Group Parts

1. Inspect cylinder block face for wear, scratches, and/or erosion. If cylinder block condition is questionable, replace the entire rotating group.
2. Remove the pistons, shoe retainer, and pivot from piston block. The piston block assembly doesn't need to be disassembled unless the internal pins or spring are damaged.
3. Check each cylinder block bore for excessive wear. Use the piston and shoe S/A (37) for this purpose. The pistons should be a very close fit and slide in and out of the cylinder block bores. **NO BINDING CAN BE TOLERATED.** If binding occurs, clean the cylinder block and pistons. Lubricate the cylinder block bores with clean fluid and try again. Even minor contamination of the fluid may cause a piston to freeze up in a cylinder bore.
4. Inspect each of the nine piston and shoe subassemblies (31) for a maximum end play of 0.005 inch between the piston and shoe. Also check the face dimension of each shoe. The face dimension must be within 0.001 inch.
5. Inspect shoe retainer and pivot for wear and/or scratches. If condition is questionable, replace entire rotating group.

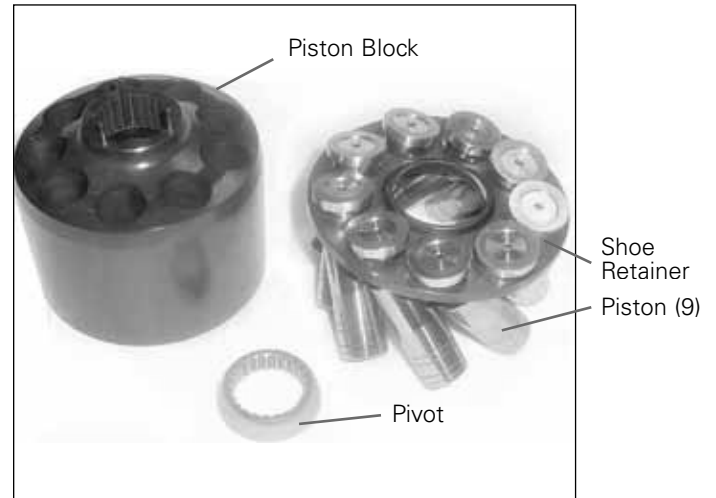

Note: Do not lap the face of piston block assembly.

Piston S/A Tolerances

This dimension must be maintained on all nine shoes within 0.001 inch.

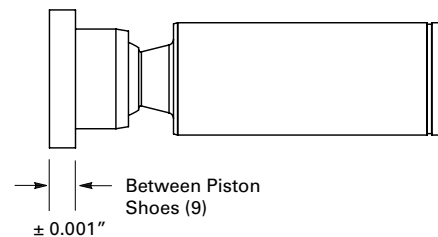

Shoe face rides on swash plate. Shoe must swivel smoothly on ball.
End play must not exceed 0.005 inch.

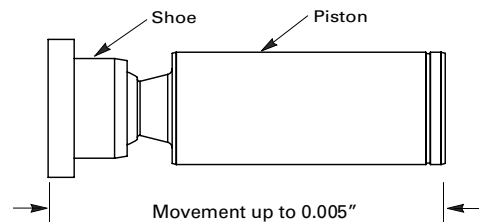

Inspection, Repair and Part Replacement

End Cover & Associated Parts

1. Inspect end cover for erosion, cracks, and burrs. Clean up minor burrs with an India stone. If erosion or cracks are found, replace the valve block.
2. Inspect roller bearing and bearing race for nicks and pitting. Make sure the roller bearing turns freely within the bearing race. If the roller bearing needs replacement, both the roller bearing and the bearing race must be replaced.
3. Inspect valve plate for erosion, excessive wear, heavy scratches, and cracks. If any of the above conditions are found, replace the valve plate.
4. Inspect control piston and maximum displacement screw for burrs, scratches and cracks. Clean up minor scratches with 500 grit paper. Remove burrs with an India stone. The control piston should move freely in the bore.

Swashplate Parts

1. Inspect swashplate face for wear, roughness or scoring. Check the swashplate hubs and bearing surfaces for wear and cracks. Replace if defective.
2. Inspect saddle bearing surfaces for wear, pitting, and smooth operation. Replace if necessary.

Shaft/Housing Parts

1. Inspect drive shaft for wear, stripped splines, and burrs. Remove burrs with an India stone. Inspect the contact area of bearing and shaft seal). Replace the drive shaft if wear or scoring is greater than 0.005 T.I.R. (total indicator reading).
2. Inspect drive shaft bearing for roughness, pitting of rollers, and excessive end play. Replace, if defective. If the bearing needs to be replaced, the bearing race also requires replacement.
3. Inspect housing mounting flange for nicks and burrs. Remove minor nicks and burrs with an India stone. Also check the housing for damaged or stripped threads. If any thread is damaged, replace the housing.
4. Check remaining pump parts for excessive wear, damaged threads, burrs, cracks and erosion. Replace any part that is in questionable condition.

Inspection, Repair and Part Replacement

Shimming Process

Kit 9900194-008

Shimming Process Installation Information

This shim kit is to replace the crush ring within the pump housing. If the housing, drive shaft, shaft bearings or end cover is replaced during servicing, the original crush ring can no longer be used to assure proper bearing set.

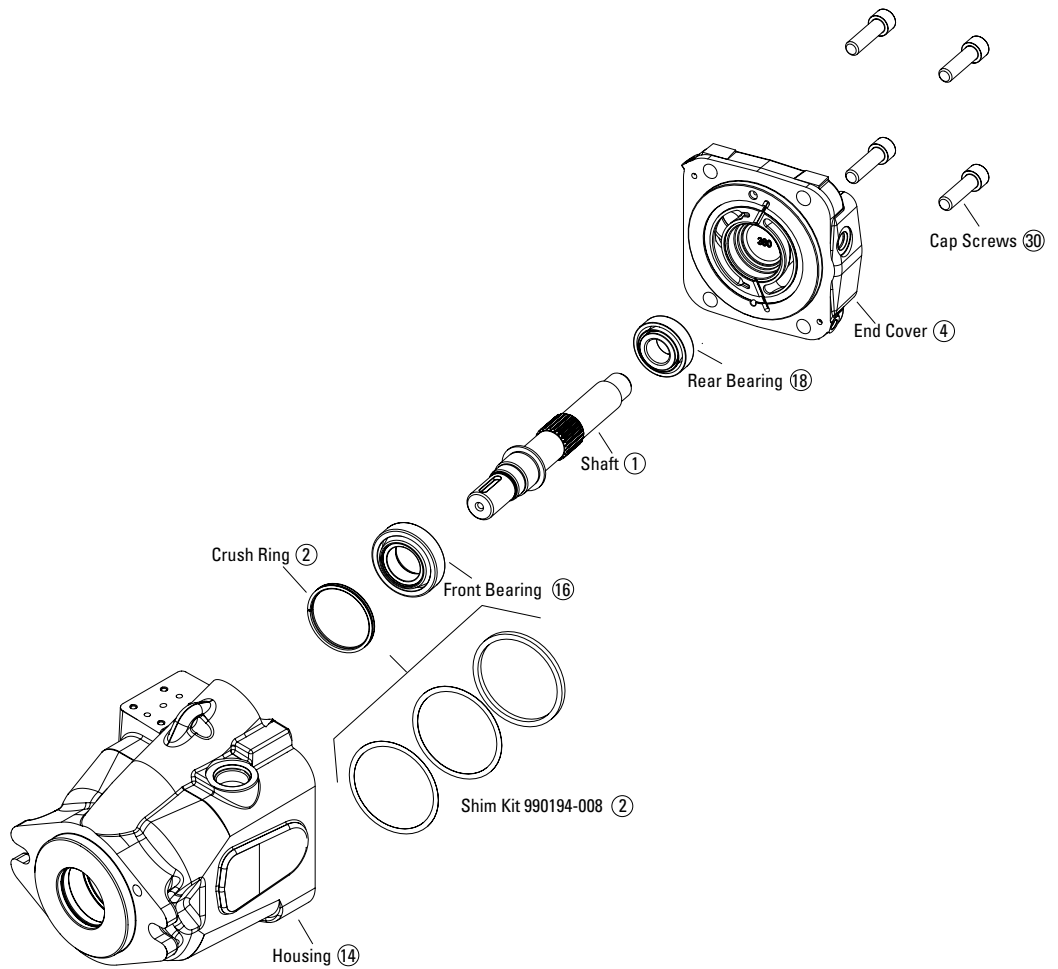

Shimming Procedures

1. Measure the thickness of the existing crush ring.
2. To obtain a starting point, stack shims to a few thousandth of an inch less than the measurement of existing crush ring. Then insert shims into the housing in the same location as the removed crush ring.
3. Assemble the housing (without interface O-ring seals), shaft bearings, shaft and end cover. Install the end cover cap screws and torque to 97+/- 9 lb-ft.
4. Using a dial indicator, measure drive shaft end play. Target bearing set range is .001" clearance to .002" interface (preload). Add shims to achieve proper bearing set. If no movement of the shaft is observed, shims will need to be removed and steps 3 and 4 repeated.
5. Finish the assembly of the pump.



Assembly

1. Remove Control Piston Plug Assembly



2. Install Swash Plate Locator Tool Adjustment will take place in step 11.



3. Remove Compensator



4. Remove End Cover Mark the housing and end cover to ensure orientation. Remove the four cap screws that hold the end cover in place. Note: The valve plate may stick to end cover. Use caution so valve plate does not fall off.



5. Remove O-ring Seal



6. Remove Valve Plate



7. Remove Bearing Race The bearing race is pressed in and will require the use of a sliding bearing removal hammer or similar tool to remove it.



8. Remove Bearing



Assembly

9. Remove Housing O-rings



11. Swashplate Adjustment Locator With the hold down tool in place, tighten the adjustment screw so the control piston spring is compressed. Note: This step is designed to force the swashplate to a neutral position to enable easy removal of the rotating group, and to retain the swashplate.



13. Remove Rotating Group



15. Remove Swashplate Locator



10. Install Swashplate Retainer Install the swash plate hold down tool and tighten the cap screw. This will prevent the swash plate from moving.



12. Install Shaft Retainer Tool Tighten the set screw while being careful not to damage shaft.



14. Remove Shaft Remove shaft retainer tool and lift out shaft. Use caution when moving shaft through shaft seal.



16. Remove Swashplate Retainer



Assembly

17. Remove Control Piston



18. Remove Swashplate



19. Remove Bias Spring



20. Remove Bearing



21. Remove Cradle Bearing Screws Caution: Socket head cap screws are easily damaged during repair with improper tool.



22. Remove Cradle Bearings Note: The cradle bearings are asymmetrical. Note proper orientation shown in picture.



23. Remove Front Bearing Race



24. Remove Shaft Seal With the seal retaining ring removed use a punch or similar tool to knock out the shaft seal.



Assembly Torque Values

Instructions

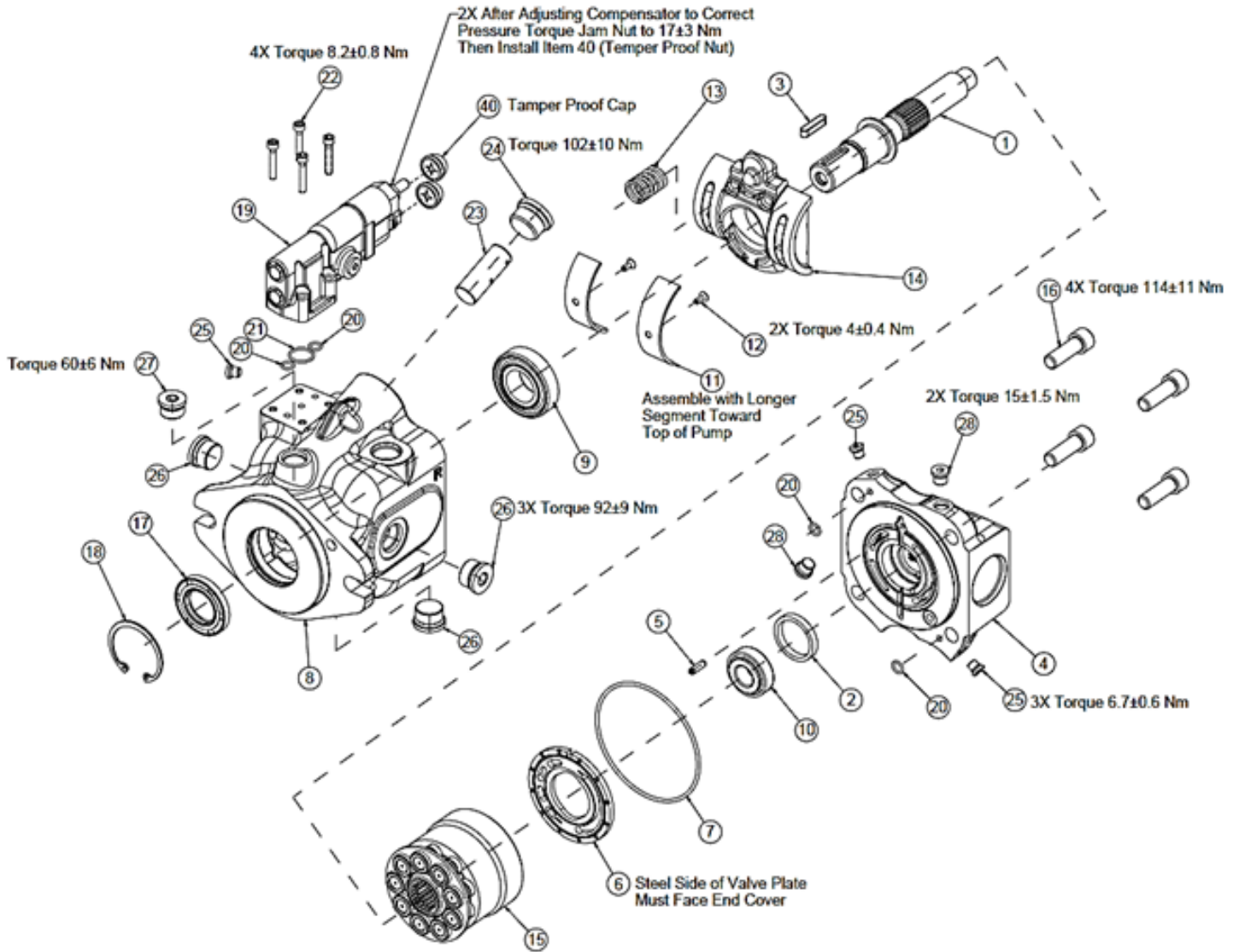

Adjustable Maximum Stop Option

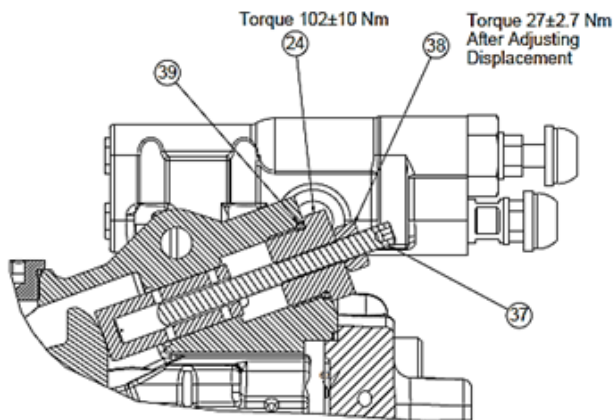

Assembly Torque Values - Instructions

Feedback Sensor Option

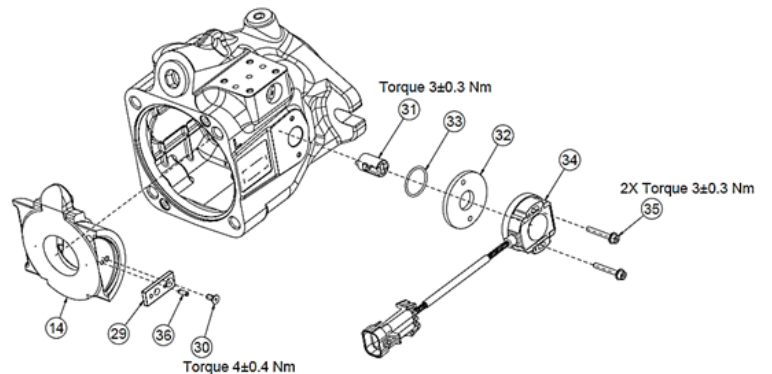

Eaton
Hydraulics Group USA
14615 Lone Oak Road
Eden Prairie, MN 55344
USA
Tel: 952-937-9800
Fax: 952-294-7722
www.eaton.com/hydraulics

Eaton
Hydraulics Group Europe
Route de la Longeraie 7
1110 Morges
Switzerland
Tel: +41 (0) 21 811 4600
Fax: +41 (0) 21 811 4601

Eaton
Hydraulics Group Asia Pacific
Eaton Building
No.7 Lane 280 Linhong Road
Changning District, Shanghai
200335 China
Tel: (+86 21) 5200 0099
Fax: (+86 21) 2230 7240



Powering Business Worldwide

© 2013 Eaton
All Rights Reserved
Printed in USA
Document No. E-PUMC-RR001-E
May 2013