



VELJAN

Service Information

SS4 - 00106

VT6EC - VT6ECM - VT6ECP

Double vane pump

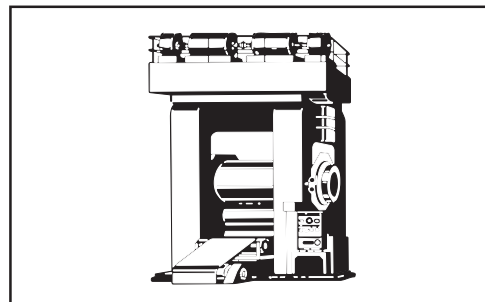
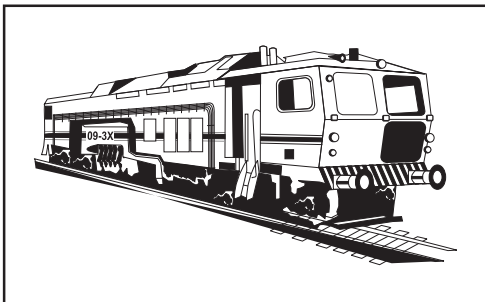
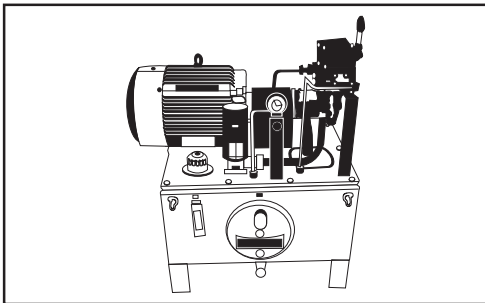
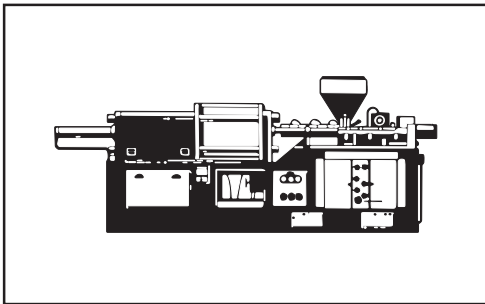

Bold printed are recommended repair kits and assemblies

Mounting torque

Item pos.	4	5
ft-lbs	50	138
N-m	68	187

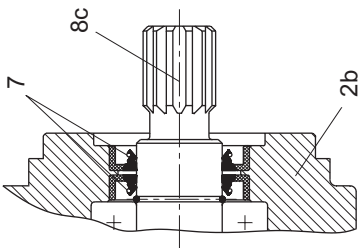
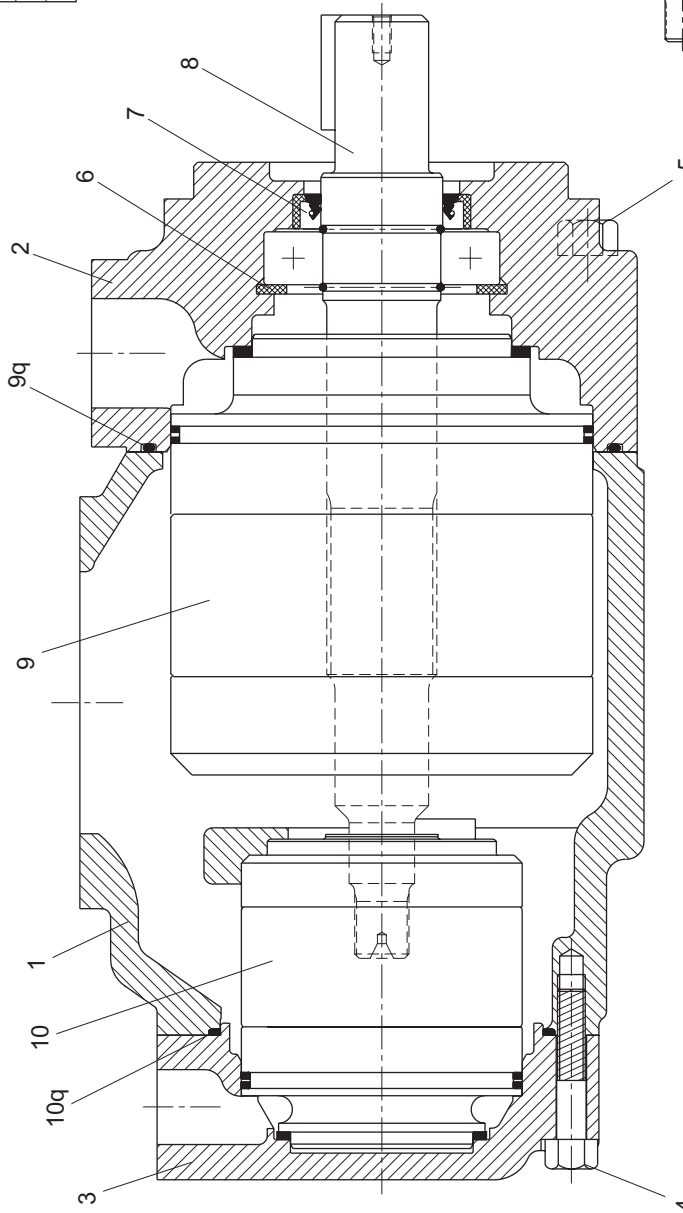

VT6ECP

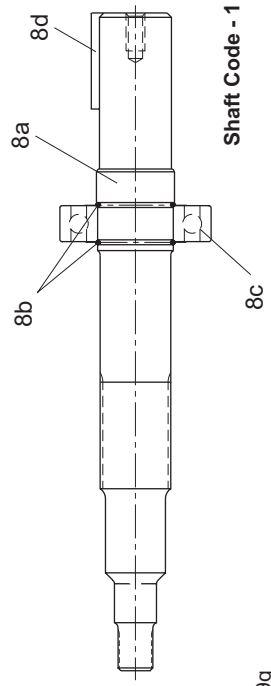

Shaft Code - 1

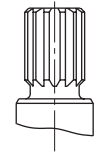

Shaft Code - 3

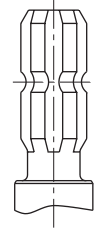

Shaft Code - T

**ITEM 9q
INCLUDED**

**ITEM 10q
INCLUDED**

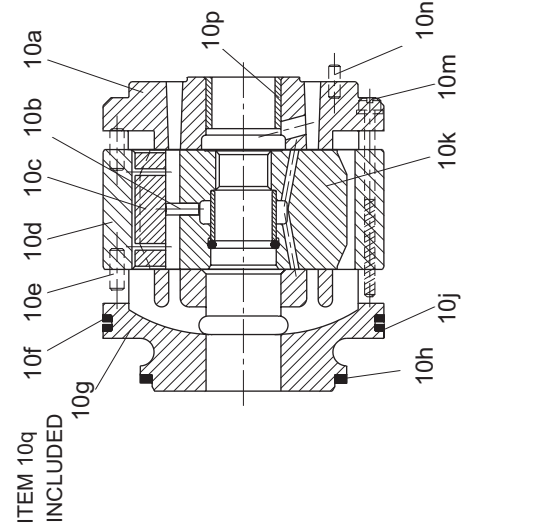
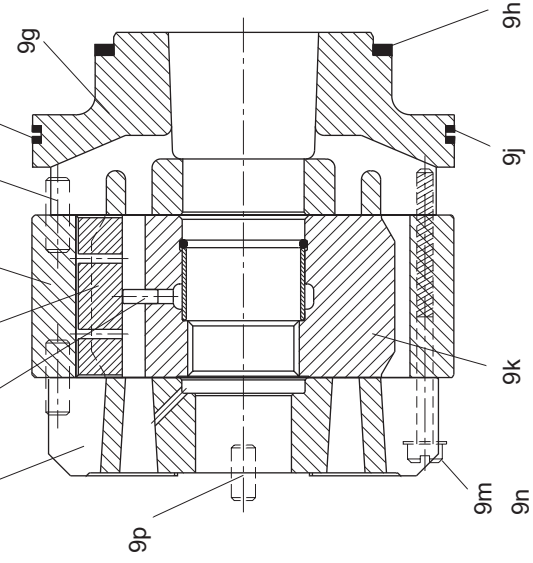

Item pos.	Description	Part No.			Qty
		VT6EC (Standard)	VT6EC (Bi-dir plates) (only for P2)	VT6ECM VT6ECP 0**-B**	
1	Housing (UNC)	V034-70263	V034-70263	V034-70263	1
	Housing (Metric)	C-034-03069	C-034-03069	C-034-03069	
2	Mounting flange (UNC)	V034-70265	V034-70265	V034-70265	1
	Mounting flange (Metric)	C-034-03070	C-034-03070	C-034-03070	
	Mounting flange (UNC) (VT6ECP)			V034-66746	
	Mounting flange (Metric) (VT6ECP)			C-034-03071	
3	End cap (UNC)	V034-48579	V034-48579	V034-48579	1
	End cap (Metric)	V034-71327	V034-71327	V034-71327	
4	Mounting Screw	V306-40111	V306-40111	V306-40111	7
5	Mounting Screw	V306-40216	V306-40216	V306-40216	4
6	Retaining ring	V356-30315	V356-30315	V356-30315	1
7	Shaft seal (S1-0.7 bar)	V620-82064	V620-82064	V620-82064	1
	Shaft seal (S4-S5-7 bar)	V620-82072	V620-82072	V620-82072	
	Shaft seal (S1-0.7 bar) (VT6ECP)			V620-82064	
8	Shaft and bearing ass'y (#1)	VS14-28178	VS14-28178	VS14-28178	1
	Shaft and bearing ass'y (#2)	VS24-49213	VS24-49213	VS24-49213	
	Shaft and bearing ass'y (#3)	VS14-28176	VS14-28176	VS14-28176	
	Shaft and bearing ass'y (#4)	VS14-28177	VS14-28177	VS14-28177	
	Shaft and bearing ass'y (#T)			VS24-33621	
	Shaft and bearing ass'y (#3) (VT6ECP)			VS24-40364	
8a	Shaft (Keyed) (Code-1)	V034-71408	V034-71408	V034-71408	1
	Shaft (Keyed) (Code-2)	V034-66891	V034-66891	V034-66891	
	Shaft (Splined) (Code-3)	V034-71315	V034-71315	V034-71315	
	Shaft (splined) (Code-4)	V034-71409	V034-71409	V034-71409	
	Shaft (Splined) (Code-T)			V034-66700	
	Shaft (Splined) (Code-3) (VT6ECP)			V034-66753	
8b	Round section ring	V034-70866	V034-70866	V034-70866	2
8c	Ball bearing	V230-03208	V230-03208	V230-03208	1
8d	Key (Code -1)	V034-70330	V034-70330	V034-70330	1
	Key (Code -2)	V034-49676	V034-49676	V034-49676	
9	Cartridge assembly 042 C.W. (P1)	VS24-49390	VS24-10205	C-S14-71569	1
	Cartridge assembly 042 C.C.W. (P1)	VS24-49391	VS24-10205	C-S14-71660	
	Cartridge assembly 045 C.W. (P1)	VS24-10205	VS24-10205	VS24-40377	
	Cartridge assembly 045 C.C.W. (P1)	VS24-10206	VS24-10206	VS24-40378	
	Cartridge assembly 050 C.W. (P1)	VS24-40769	VS24-40769	VS24-40771	
	Cartridge assembly 050 C.C.W. (P1)	VS24-40770	VS24-40770	VS24-40772	
	Cartridge assembly 052 C.W. (P1)	VS24-10207	VS24-10207	VS24-40379	
	Cartridge assembly 052 C.C.W. (P1)	VS24-10208	VS24-10208	VS24-40380	
	Cartridge assembly 062 C.W. (P1)	VS24-10209	VS24-10209	VS24-40381	
	Cartridge assembly 062 C.C.W. (P1)	VS24-10210	VS24-10210	VS24-40382	
	Cartridge assembly 066 C.W. (P1)	VS24-10211	VS24-10211	VS24-40383	
	Cartridge assembly 066 C.C.W. (P1)	VS24-10212	VS24-10212	VS24-40384	
	Cartridge assembly 072 C.W. (P1)	VS24-40375	VS24-40375	VS24-40385	
	Cartridge assembly 072 C.C.W. (P1)	VS24-40376	VS24-40376	VS24-40386	
	Cartridge assembly 085 C.W. (P1)	VS24-59352		C-S14-71663	
Cartridge assembly 085 C.C.W. (P1)	VS24-68983		C-S14-71664		
9a	Port plate - rear C.W.	V034-59082	V034-59082	V034-59082	1
	Port plate - rear C.C.W.	V034-59083	V034-59083	V034-59083	
9b	Pin vane holdout	V034-59161	V034-59161	V034-70259	12
9c	Vane	V034-59162	V034-59162	V034-59162	12
9d	Cam ring - 042	V034-66899	V034-66899	V034-66899	1
	Cam ring - 045	V034-59164	V034-59164	V034-59164	
	Cam ring - 050	V034-66744	V034-66744	V034-66744	
	Cam ring - 052	V034-59165	V034-59165	V034-59165	

Item pos.	Description	Part No.			Qty
		VT6EC (Standard)	VT6EC (Bi-dir plates) (only for P2)	VT6ECM VT6ECP	
	Cam ring - 062	V034-59166	V034-59166	V034-59166	
	Cam ring - 066	V034-59167	V034-59167	V034-59167	
	Cam ring - 072	V034-66736	V034-66736	V034-66736	
	Cam ring - 085	V034-67030	V034-67030	V034-67030	
9e	Dowel pin	V324-22016	V324-22016	V324-22016	2
9f	Back-up ring	V618-15018	V618-15018	V618-15018	1
9g	Port plate - pressure C.W.	V034-59159	V034-59159	V034-59159	1
	Port plate - pressure C.C.W.	V034-59160	V034-59160	V034-59160	
9h	Sq. section seal	V691-10237	V691-10237	V691-10237	1
9j	Sq. section seal	V691-10253	V691-10253	V691-10253	1
9k	Rotor-insert ass'y	VS24-10185	VS24-10185	VS24-30019	1
9m	Screw	V310-10340	V310-10340	V310-10340	2
9n	Lockwasher internal tooth	V348-10010	V348-10010	V348-10010	2
9p	Dowel pin	V323-82014	V323-82014	V323-82014	1
9q	Sq. section seal	V671-10259	V671-10259	V671-10259	1
10	Cartridge assembly *03 C.W. (P2)	VS24-10767	VS24-26607	VS24-40175	1
	Cartridge assembly *03 C.C.W. (P2)	VS24-10768	VS24-26608	VS24-40176	
	Cartridge assembly *05 C.W. (P2)	VS24-10769	VS24-26609	VS24-40177	
	Cartridge assembly *05 C.C.W. (P2)	VS24-10770	VS24-26610	VS24-40178	
	Cartridge assembly *06 C.W. (P2)	VS24-10771	VS24-26611	VS24-40179	
	Cartridge assembly *06 C.C.W. (P2)	VS24-10772	VS24-26612	VS24-40180	
	Cartridge assembly *08 C.W. (P2)	VS24-10773	VS24-26613	VS24-40181	
	Cartridge assembly *08 C.C.W. (P2)	VS24-10774	VS24-26614	VS24-40182	
	Cartridge assembly *10 C.W. (P2)	VS24-10775	VS24-26615	VS24-40183	
	Cartridge assembly *10 C.C.W. (P2)	VS24-10776	VS24-26616	VS24-40184	
	Cartridge assembly *12 C.W. (P2)	VS24-26480	VS24-26617	VS24-40185	
	Cartridge assembly *12 C.C.W. (P2)	VS24-26481	VS24-26618	VS24-40186	
	Cartridge assembly *14 C.W. (P2)	VS24-10777	VS24-26619	VS24-40187	
	Cartridge assembly *14 C.C.W. (P2)	VS24-10778	VS24-26620	VS24-40188	
	Cartridge assembly *17 C.W. (P2)	VS24-10779	VS24-26621	VS24-40189	
	Cartridge assembly *17 C.C.W. (P2)	VS24-10780	VS24-26622	VS24-40190	
	Cartridge assembly *20 C.W. (P2)	VS24-40234	C-S14-71678	VS24-40191	
	Cartridge assembly *20 C.C.W. (P2)	VS24-40235	C-S14-71679	VS24-40192	
	Cartridge assembly *22 C.W. (P2)	VS24-10781	VS24-26623	VS24-40193	
	Cartridge assembly *22 C.C.W. (P2)	VS24-10782	VS24-26624	VS24-40194	
	Cartridge assembly *25 C.W. (P2)	VS24-10783	VS24-26625	VS24-40195	
	Cartridge assembly *25 C.C.W. (P2)	VS24-10784	VS24-26626	VS24-40196	
	Cartridge assembly *28 C.W. (P2)	VS14-97722	VS24-26627	VS24-40197	
	Cartridge assembly *28 C.C.W. (P2)	VS24-25791	VS24-26628	VS24-40198	
	Cartridge assembly *31 C.W. (P2)	VS24-45789	VS24-26629	VS24-45795	
	Cartridge assembly *31 C.C.W. (P2)	VS24-45790	VS24-26630	VS24-45796	
10a	Port plate - rear C.W.	V034-59777			1
	Port plate - rear C.C.W.	V034-59776			
	Port plate - rear Bi-dir		V034-59118	V034-59118	
10b	Pin vane holdout	V034-59098	V034-59098	V034-24982	10
10c	Vane	V034-59099	V034-59099	V034-66716	10
10d	Cam ring - 003	V034-59050	V034-59050	V034-59050	1
	Cam ring - 005	V034-59051	V034-59051	V034-59051	
	Cam ring - 006	V034-59052	V034-59052	V034-59052	
	Cam ring - 008	V034-59053	V034-59053	V034-59053	
	Cam ring - 010	V034-59054	V034-59054	V034-59054	
	Cam ring - 012	V034-66595	V034-66595	V034-66595	
	Cam ring - 014	V034-59206	V034-59206	V034-59206	
	Cam ring - 017	V034-59207	V034-59207	V034-59207	
	Cam ring - 020	V034-66607	V034-66607	V034-66607	

Item pos.	Description	Part No.			Qty
		VT6EC (Standard)	VT6EC (Bi-dir plates) (only for P2)	VT6ECM VT6ECP	
	Cam ring - 022	V034-59208	V034-59208	V034-59208	
	Cam ring - 025	V034-59209	V034-59209	V034-59209	
	Cam ring - 028	V034-59245	V034-59245	V034-59245	
	Cam ring - 031	V034-66843	V034-66843	V034-66843	
10e	Dowel pin	V324-21208	V324-21208	V324-21208	2
10f	Back-up ring	V618-15016	V618-15016	V618-15016	1
10g	Port plate - pressure C.W.	V034-59773			1
	Port plate - pressure C.C.W.	V034-59772			
	Port plate - pressure Bi-dir		V034-66453	V034-66453	
10h	Sq. section seal	V691-10229	V691-10229	V691-10229	1
10j	Sq. section seal	V691-10238	V691-10238	V691-10238	1
10k	Rotor-insert ass'y	VS24-10116	VS24-10116	VS24-30049	1
10m	Screw	V317-06266	V317-06266	V317-06266	2
10n	Dowel pin	V323-82010	V323-82010	V323-82010	1
10p	Bush	V034-70868	V034-70868	V034-70868	1
10q	Sq. section seal	V671-10156	V671-10156	V671-10156	1
7 9f,9h 9j,9q 10f,10h 10j,10q	Seal kit (S1 - 0,7 bar)	VS24-10242	VS24-10242	VS24-10242	1
	Seal kit (S4 - 7 bar)	VS24-10242-4	VS24-10242-4	VS24-10242-4	
	Seal kit (S5 - 7 bar)	VS24-10242-5	VS24-10242-5	VS24-10242-5	
	Seal kit (S1 - 0,7 bar) (VT6ECP)			VS24-40365	
9a	Port plate - rear ass'y C.W. (P1)	VS24-10214		VS24-10214	1
	Port plate - rear ass'y C.C.W. (P1)	VS24-10215		VS24-10215	
10a	Port plate - rear and bush ass'y C.W. (P2)	VS24-10809			1
10p	Port plate - rear and bush ass'y C.C.W. (P2)	VS24-10810			
	Port plate - rear and bush ass'y Bi-dir (P2)		VS24-10139	VS24-10139	

* 0 - Standard
B - Bi-directional plates/Mobile
R - Mobile-spring assisted (on request)

To change porting position, follow the steps below:

1. Secure pump and remove 4 bolts from mounting flange. Move the mounting flange 1 to 2 mm away from housing. Insert one bolt halfway to mounting flange. Install a wrench between the shaft and bolt and turn in the desired way, so that the required position of P1 port with respect to Suction is obtained. Reinstall the bolts and tighten to corresponding mounting torque as provided on page 2.
2. Follow similar procedure for changing P2 position. Use wrench between two bolts placed diagonally opposite.

Instruction : Do not remove mounting flange/end cap completely from the housing but only just 1 to 2 mm to avoid the cartridge pin to move out from the housing dowel pin hole. Make sure no piece of paint enters into the gap to avoid leakage.

If it is difficult to turn mounting flange/end cap put some hydraulic oil into the pressure port to lubricate the pressure port seals.

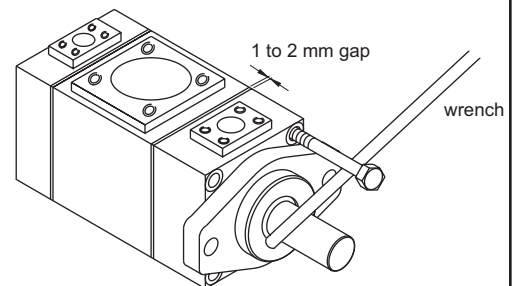

MODEL CODE

Series

- * **M** = Mobile
- * **P** = Mobile with double shaft seal
(* omit for Industrial)
- Y** = Metric port connection, omit for UNC

VT6EC * * * - * **66** - * **10** - **1 R 00 - C 1 - ***

Modification

Seal class

- 1** = S1 - BUNAN
- 4** = S4 - EPDM
- 5** = S5 - VITON

Design letter

- B** = Industrial
- C** = Mobile

Porting combination : (00 = Standard)

Cam ring — Displacement — Cam ring — Displacement

	in ³ /rev (cm ³ /rev)		in ³ /rev (cm ³ /rev)
042/R42	= 8.07 (132.30)	062/R62	= 12.00 (196.70)
045/R45	= 8.70 (142.40)	066/R66	= 13.00 (213.30)
050/R50	= 9.67 (158.50)	072/R72	= 13.86 (227.10)
052/R52	= 10.00 (164.80)	085/R85	= 16.40 (269.80)

Cam ring — Displacement — Cam ring — Displacement

	in ³ /rev (cm ³ /rev)		in ³ /rev (cm ³ /rev)
003/B03/R03	= 0.66 (10.80)	017/B17/R17	= 3.56 (58.30)
005/B05/R05	= 1.05 (17.20)	020/B20/R17	= 3.89 (63.80)
006/B06/R06	= 1.30 (21.30)	022/B22/R22	= 4.29 (70.30)
008/B08/R08	= 1.61 (26.40)	025/B25/R25	= 4.84 (79.30)
010/B10/R10	= 2.08 (34.10)	028/B28/R28	= 5.42 (88.80)
014/B14/R14	= 2.81 (46.00)	031/B31/R31	= 6.10 (100.00)

(Select 'B'*** for Mobile and Bi-directional)

(Select 'R'*** for Mobile-spring assisted)

Type of Shaft

VT6EC	1 = Keyed (SAE -CC)
	2 = Keyed (no SAE)
	3 = Splined (SAE-C)
	4 = Splined (SAE-CC)

Type of Shaft

VT6ECM	1 = Keyed (SAE -CC)
	2 = Keyed (no SAE)
	3 = Splined (SAE -C)
	4 = Splined (no SAE)
	T = Splined (SAE J718c)

Type of Shaft

VT6ECP	3 = Splined (no SAE)
---------------	-----------------------------

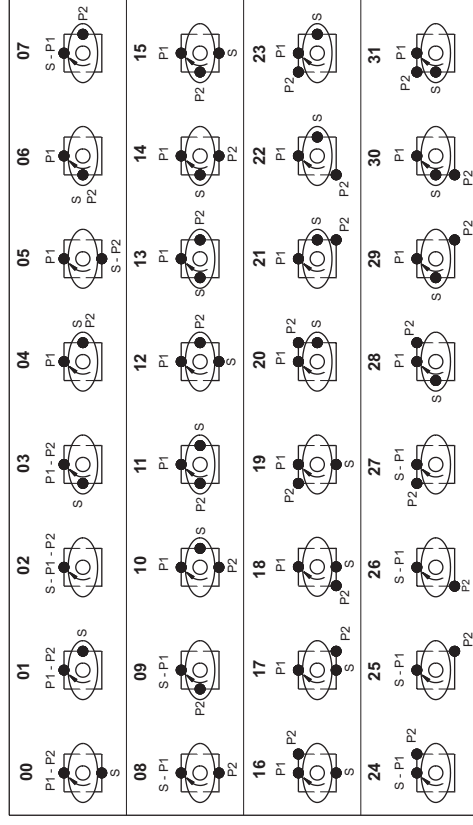

Direction of rotation

- R** = Clockwise
- L** = Counter - clockwise

P - Pressure S - Suction

Veijan Hydrair Limited, Balanagar, Hyderabad - 500 037, INDIA . Phone : +91-40-3772794,95 Fax : +91-40-3773963, www.veijan.com

©All Rights Reserved
Product details are liable to change without prior notice

Print	VHL/6/12/1k
Replace	
Revision	
Printed in India	