



HY13-1521-M1/US

# Parker Hydrostatic Tandem Pumps

 [www.khadamathydraulic.com](http://www.khadamathydraulic.com)  
Tell: 021-55882749  
Tell: 021-33488178  
Fax: 021-33488105

Effective: March, 2009

---



## HP2 Series Hydrostatic Tandem Pump Service Procedure

---

**WARNING**

FAILURE OR IMPROPER SELECTION OR IMPROPER USE OF THE PRODUCTS AND/OR SYSTEMS DESCRIBED HEREIN OR RELATED ITEMS CAN CAUSE DEATH, PERSONAL INJURY AND PROPERTY DAMAGE.



This document and other information from Parker Hannifin Corporation, its subsidiaries and authorized distributors provide product and/or system options for further investigation by users having technical expertise. It is important that you analyze all aspects of your application and review the information concerning the product or system in the current product catalog. Due to the variety of operating conditions and applications for these products or systems, the user, through his/her own analysis and testing, is solely responsible for making the final selection of the products and systems and assuring that all performance, safety and warning requirements of the application are met.

The products described herein, including without limitation, product features, specifications, designs, availability and pricing, are subject to change by Parker Hannifin Corporation and its subsidiaries at any time without notice.

© Copyright 2008, Parker Hannifin Corporation, All Rights Reserved

<b>Section 1</b>	<b>General Information</b>	
	Definitions/Disclaimer .....	4
	Introduction/Design Features.....	5
	Troubleshooting Guide .....	6
	Troubleshooting Checklist.....	7
	Tools & Materials Required for Servicing .....	8
	Exploded Views.....	9-12
<b>Section 2</b>	<b>Reseal &amp; Repair</b>	
	Disassembly .....	13-32
	Assembly.....	33-51
<b>Section 3</b>	<b>Maintenance</b>	
	System Maintenance Tips.....	52
	Hydraulic Fluids .....	53
	Filtration .....	53
	Oil Temperature.....	53

## Definitions

	<b>WARNING</b>	<b>A warning describes hazards or unsafe practices which could result in severe personal injury or death.</b>
	<b>CAUTION</b>	A caution describes hazards or unsafe practices which could result in personal injury, product or property damage.
	<b>NOTE</b>	A note gives key information to make following a procedure easier or quicker.

## Disclaimer

This Service Manual has been prepared by Parker Hannifin Corporation for reference and use by mechanics who have been trained to repair and service hydraulic pumps on commercial and non-commercial equipment applications. Parker Hannifin Corporation has exercised reasonable care and diligence to present accurate, clear and complete information and instructions regarding the techniques and tools required for maintaining, repairing and servicing the Parker HP2 Series Hydrostatic Tandem Pump. Since this is a general Service Manual, the photographs and illustrations may not look exactly like the pump being serviced. The procedures, therefore, must be carefully read and understood before servicing.

If inspection or testing reveals evidence of abnormal wear or damage to the HP2 Tandem Pump or if you encounter circumstances not covered in the Manual, STOP - CONSULT THE EQUIPMENT MANUFACTURER'S SERVICE MANUAL AND WARRANTY. DO NOT TRY TO REPAIR OR SERVICE A HP2 TANDEM PUMP WHICH HAS BEEN DAMAGED OR INCLUDES ANY PART THAT SHOWS EXCESSIVE WEAR UNLESS THE DAMAGED AND WORN PARTS ARE REPLACED WITH ORIGINAL PARKER REPLACEMENT AND SERVICE PARTS AND THE UNIT IS RESTORED TO PARKER SPECIFICATIONS FOR THE HP2 TANDEM PUMP.

It is the responsibility of the mechanic performing the maintenance, repairs or service on a particular HP2 Tandem Pump to (a) inspect the unit for abnormal wear and damage, (b) choose a repair procedure which will not endanger his/her safety, the safety of others, the equipment or the safe operation of the HP2 Tandem Pump, and (c) fully inspect and test the HP2 Tandem Pump and the hydraulic system to ensure that the repair or service of the HP2 Tandem Pump has been properly performed and that the HP2 Tandem Pump and hydraulic system will function properly.

## Conversions

	<b>INCHES</b>	<b>mm</b>	<b>INCHES</b>	<b>mm</b>
	.020	.511	1.060	26.92
	.021	.531	1.295	32.89
	.029	.741	1.297	32.94
	.030	.760	1.396	35.46
	.111	2.81	1.398	35.51
	.119	3.02	1.620	41.15
	.152	3.86	1.622	41.20
	.160	4.06	1.983	50.37
	.296	7.52	1.985	50.42
	.304	7.72	2.120	53.85
	.460	11.68	2.122	53.90
	.470	11.94	2.233	56.72
	.500	12.70	2.235	56.77
	.585	14.86	2.483	63.07
	.595	15.11	2.485	63.12
	.660	16.76	2.500	63.5
	.675	17.15	2.88	73.2
	1.058	26.87		

## Introduction

The three-column format used in this Service Manual will help make it easy for you to service a hydraulic pump. Column 1 illustrates the procedure with photographs, Column 2 gives a brief key for each step, and Column 3 explains in detail the procedure you should follow. Pay special attention to the notes, cautions and warnings.

This manual contains troubleshooting information and checklists. With them you can diagnose a hydraulic system problem without removing the HP2 Tandem Pump. The checklists will help you to determine where the problem may be.

Item numbers on the exploded view correspond with item numbers used throughout the Service Manual.

As you gain experience in servicing the HP2 Tandem Pump, you may find that some information in this Service Manual could be clearer and more complete. If so, let us know about it. Don't try to second-guess the Service Manual; if problems occur that you cannot solve, please contact our service department at 423-639-8151, or your local Parker approved distributor. Servicing the HP2 Tandem Pump should be safe and productive. Visit our web site at [www.parker.com/pumpmotor](http://www.parker.com/pumpmotor).

### HP2 SERIES VARIABLE DISPLACEMENT, CLOSED LOOP DUAL PISTON PUMP

- Large area cooling fins result in a cooler running system
- Center block and housings are sturdy, lightweight aluminum, excellent at dispersing heat, resulting in an overall cooler system
- Replaceable bi-metal port plate increases contamination resistance and efficiency of pump as well as serviceability
- Forged trunnion shaft increases shaft strength and lengthens pump life
- Nylon caged thrust bearings improve lubrication and vibration absorption, thus lengthening life of pump
- Compact size for similar systems for increased flexibility in machine design
- Larger radial shaft bearings (20mm) provide additional side load capacity and less machine downtime
- 18% larger shaft than competitive pumps for reduced shaft breakage
- Smaller diameter pistons reduce load on thrust bearings compared to competitive pumps
- Reduced maximum swash plate angle lowers piston-to-bore velocity and enables pistons to be more centered on the thrust bearing when swash plate is inclined resulting in increased pump and bearing life
- Two independently controlled, variable displacement, over-center piston pumps
- Single input drive shaft
- 2.5 quart integral reservoir
- Integral filter and system cooling fan

## Troubleshooting Guide

**NOTE** Before troubleshooting any system problem, check service literature published by the equipment and/or component manufacturers. Follow their instructions, if given, for checking any component other than the HP2 Tandem pump.

### Preparation

Make your troubleshooting easier by preparing as follows:

- work in a clean, well-lighted place
- have proper tools and materials nearby
- have an air pressure source.

**WARNING** Since solvents are flammable, be extremely careful when using any solvent. Even a small explosion could cause injury or death.



**WARNING** Wear eye protection and be sure to comply with OSHA and other maximum air pressure requirements.



### Preliminary Checks

Hydraulic systems are often trouble-free. Hence, the problem an operator complains of could be caused by something other than the hydraulic components.

Thus, once you have determined that a problem exists, start with the easy-to-check items, such as:

- Parts damaged from impact that were not properly repaired, or that should have been replaced
- Improper replacement parts used in previous servicing
- Mechanical linkage problems such as binding, broken or loose parts, or slipping belts

### Hydraulic Components

If you think the problem is caused by a hydraulic component, start by checking the easy-to-reach items.

Check all hoses and lines for cracks, hardening or other signs of wear. Reroute any usable hoses that are kinked, severely bent, or that rest against hot parts. Look for leaks, especially at couplings and fittings. Replace any hoses or lines that don't meet system flow and pressure ratings.

Next, go to the reservoir and filters. Check fluid level and look for air bubbles. Check the filter(s). A filter with a maximum of 20 micron filtration is included for the HP2 Tandem pump system.

Visually check other components to see if they are loosely mounted, show signs of leaks, or other damage or wear.

Excessive heat in a hydraulic system can create problems that can easily be overlooked. Every system has its limitation for the maximum amount of temperature. After the maximum temperature is attained and passed, the following can occur:

- oil seal leaks
- pump loss of efficiency (resulting in lower transmission speeds)
- pump failure
- hoses become hard and brittle
- hose failure

A normal temperature range means an efficient hydraulic system. Consult the manuals published by equipment and/or component manufacturers for maximum allowable temperatures and hydraulic tests that may be necessary to run on the performance of the hydraulic components. The HP2 Tandem pump is not recommended for hydraulic systems with maximum temperatures above 230° F (110° C).

## Troubleshooting Checklist

<b>Trouble</b>	<b>Cause</b>	<b>Remedy</b>
<b>Oil Leakage</b>	1. Damaged seal.	Remove debris, replace seals using seal kit p/n SK000234 for HP2 Tandem pump.
	2. Air trapped in system.	Purge system per instructions.
<b>Operates Hot</b>	1. Debris buildup.	Remove debris.
	2. Cooling fan damaged.	Replace fan.
	3. Oil level low or contaminated.	Fill or change oil and filter.
	4. Excessive loading.	Reduce vehicle load.
	5. Air trapped in system.	Purge per instructions.
	6. Inlet leak.	Check all external connections to inlet.
<b>No / Low Power</b>	1. Engine speed low.	Adjust setting.
	2. Oil level low or contaminated.	Fill or change oil and filter.
	3. Bypass loose.	Tighten.
	4. Excessive loading.	Reduce vehicle load.
	5. Air trapped in system.	Purge per instructions.
	6. Inlet leak.	Check all external connections to inlet.
	7. Clogged inlet filter.	Replace.
	8. Suspect internal damage.	Disassemble and inspect.
<b>Noisy Unit</b>	1. Excessive speed input.	Adjust input speed above 1800 rpm and below 3600 rpm.
	2. Oil level low or contaminated.	Fill or change oil and filter.
	3. Excessive loading.	Reduce vehicle load.
	4. Air trapped in system.	Purge per instructions.
	5. Inlet leak.	Check all external connections to inlet.
	6. Bypass loose.	Tighten bypass.

## Tools and Materials Required for Servicing

- Clean, petroleum-based solvent
- Emery paper
- Vice with soft jaws
- Air-pressure source
- Arbor press
- Flat screwdriver
- Grease pencil or paint pen
- Small gear puller
- 3/8" torque wrench: 155-190 in-lbs, 282-342 in-lbs, 90-110 in-lbs, 160-200 in-lbs
- Sockets: 3/8" drive ratchet, 5/8", 9/16" and 13mm, 11/16, 1/4" Allen, 5/16" Allen
- Allen wrenches: 1/4" and 5/16"
- Combination wrenches: 9/16" for fan part only
- Vise grip™ pliers
- Internal snap ring pliers
- Clean corrosion resistant grease. Recommended grease is Mobil Mobilith SHC® 460 or equivalent.
- Rubber hammer

---

**CAUTION**  Mixing greases that have different bases can be detrimental to bearing life.

---



**Exploded View - Typical**

SK000234		Parts List	
ITEM	QTY	PART NUMBER	DESCRIPTION
1	1	478001	SEAL (SHAFT)
2	1	028008	WASHER (SEAL)
3	1	401114	INTERNAL RETAINING RING (SHAFT SEAL)
4	2	478002	SEAL (TRUNNION ARM)
5	2	401303	RETAINING RING (TRUNNION ARM)
6	2	478085	SEAL (TANDEM PUMP, HOUSINGS)
7	1	032011	O-RING (CHARGE PUMP)
8	2	032002	O-RING (BYPASS VALVE)
9	2	MS28774-012	BACKUP RING (BYPASS VALVE)
10	1	032010	SEAL (FAN DRIVE)
11	1	401305	SPRING
12	1	409032	BALL (1/4)

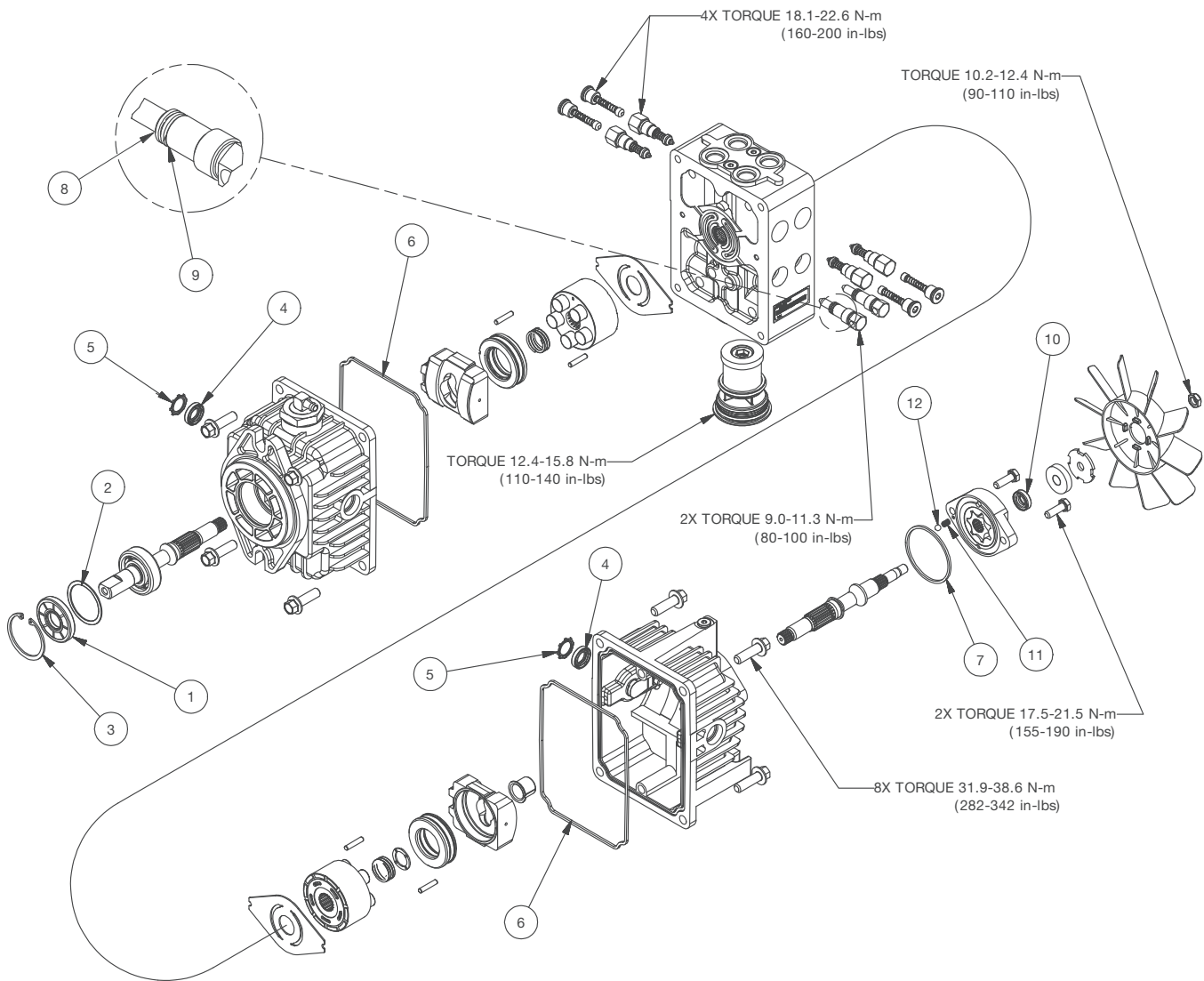

Parts List				
ITEM	QTY	DESCRIPTION	12 cc PART NUM	16 cc PART NUM
1	1	ADAPTOR ASSEMBLY	411118	411118
2	2	THRUST BEARING ASSEMBLY	068029	068030
3	2	SEAL	478085	478085
4	1	SHAFT SEAL	478001	478001
5	1	REAR SHAFT	HP2019000R	HP2019000R
6	1	CHARGE PUMP ASSEMBLY	HP2018003A1	HP2018004A1
7	1	BUSHING	060001	060001
8	2	SWASH BLOCK	H1A013000	HP2013001
9	2	CONTROL BLOCK	452002	452011
10	1	INTERNAL RETAINING RING (SHAFT SEAL)	401114	401114
11	2	SPRING (CENTRAL)	401302	401717
12	4	PLUG	036137	036137
13	4	DOWEL PIN	040003	040003
14	1	SPRING	401305	401305
15	1	BALL (1/4)	409032	409032
16	1	O-RING (CHARGE PUMP)	032011	032011
17	8	SCREW (10 mm)	022008	022008
18	1	WASHER	028008	028008
19	2	SCREW (CHARGE PUMP)	022002	022002
20	1	IDENTIFICATION TAG	030042	030042
21	1	WASHER (FAN DRIVE)	028013	028013
22	1	STOP NUT (FAN DRIVE)	026046	026046
23	1	SPACER (FAN DRIVE)	477364	477364
24	1	WASHER (SEAL)	029127	029127
25	1	FILTER	411119	411119
26	2	PORT PLATE	CONSULT HPM	CONSULT HPM
27	2	PISTON & BARREL ASSEMBLY	H1A127000	HP2167000
28	1	FRONT HOUSING ASSEMBLY	HP2012000FA1	HP2012001FA1
29	1	REAR HOUSING ASSEMBLY	HP2012000RA1	HP2012001RA1
30	1	SHAFT ASSEMBLY (20 mm DOUBLE "D")	HP2019000FA1	HP2019000FA1
31	1	CENTER BLOCK ASSEMBLY	HP2016000A1	HP2016001A1
32	1	FAN	420004	420066
33	4	SHOCK VALVE ASSEMBLY	CONSULT HPM	CONSULT HPM
34	4	CHECK VALVE ASSEMBLY	CONSULT HPM	CONSULT HPM

### Exploded View - Typical

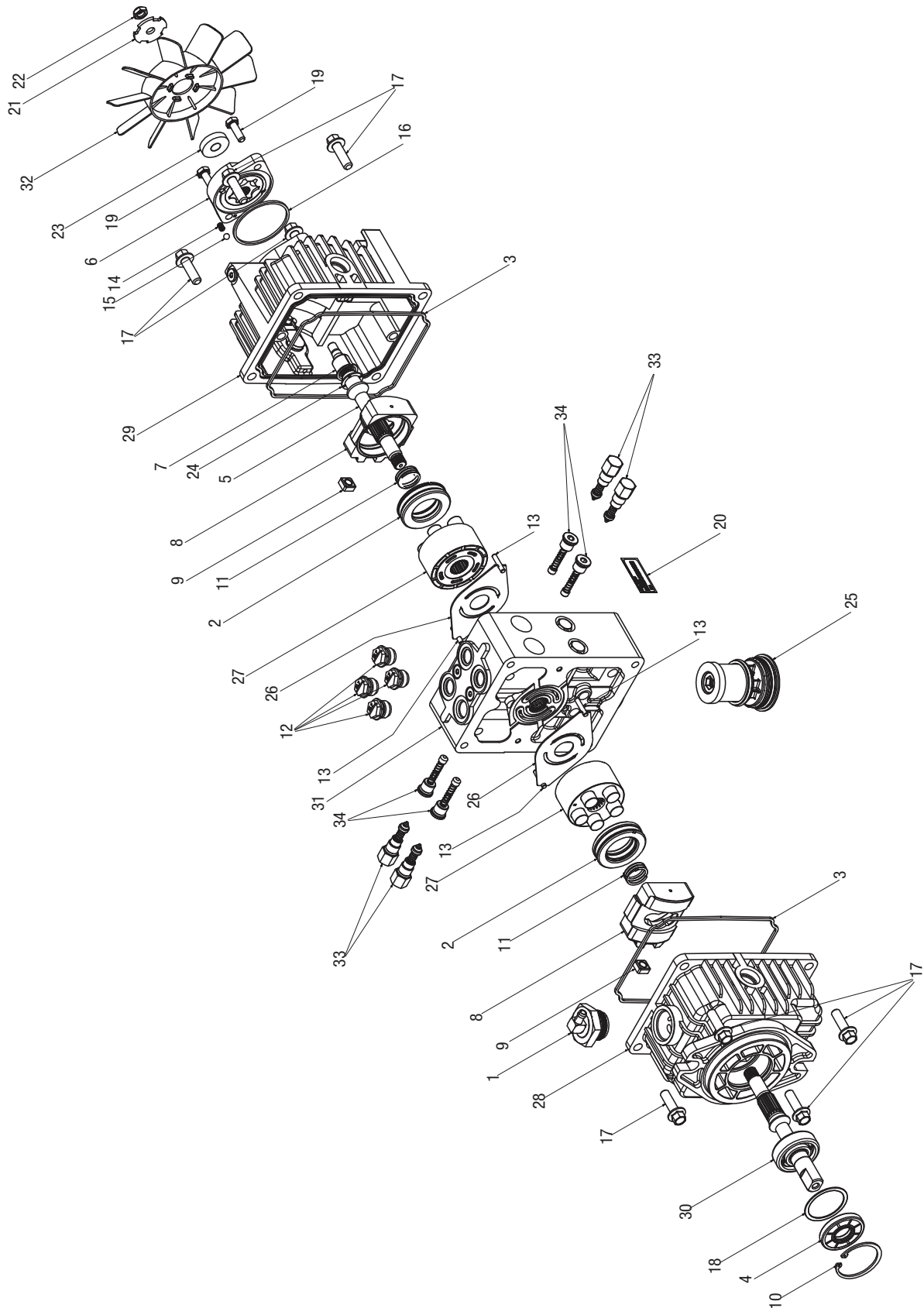

**Dimensional Data**

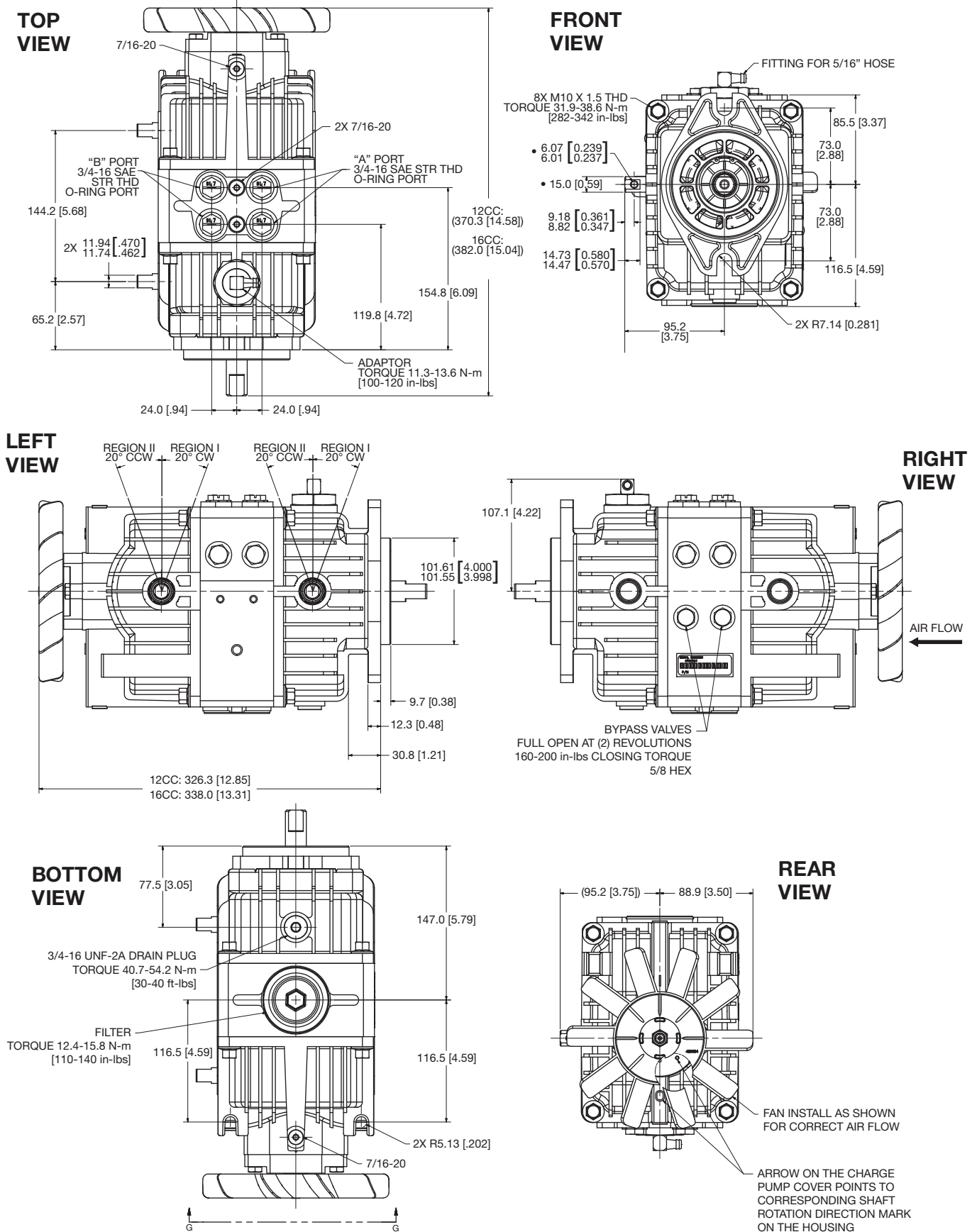

Before you disassemble the HP2 Tandem pump or any of its components, read this entire manual. It provides important information on parts and procedures you will need to know to service the HP2 Tandem pump.

Thoroughly clean off all outside dirt, especially from around fittings and hose connections before disconnecting and removing the HP2 Tandem pump. Remove rust or corrosion from the coupling shaft.

Remove shaft connections and hose fittings and immediately plug port holes and fluid lines.

Remove the HP2 Tandem pump from the system, drain it of fluid and take it to a clean work surface.

Clean and dry the HP2 Tandem pump before you start to disassemble the unit.

As you disassemble the HP2 Tandem pump, clean all parts, except seals, in clean, OSHA approved solvent, and air blow them dry.

---

**WARNING** Since they are flammable, be extremely careful when using any solvent. Even a small explosion or fire could cause injury or death.



---

**WARNING** Wear eye protection and be sure to comply with OSHA and other maximum air pressure requirements.



---

**WARNING** Never steam or high pressure wash hydraulic components. Do not force or abuse closely fitted parts.



---

Keep parts separate to avoid nicks and burrs.

Discard all seals and seal rings as they are removed from the HP2 Tandem pump. Replace all seal rings and any damaged or worn parts with genuine Parker Hannifin Corporation or OEM approved service parts.



**Removal of fan**

1. Clean and remove debris from exterior of pump to prevent contamination. Secure pump in vise using only mounting flange to prevent damage while servicing.

---

**NOTE** Before troubleshooting any system problem, check service literature published by the equipment and/or component manufacturers. Follow their instructions, if given, for checking any component other than the HP2 Tandem pump.

---

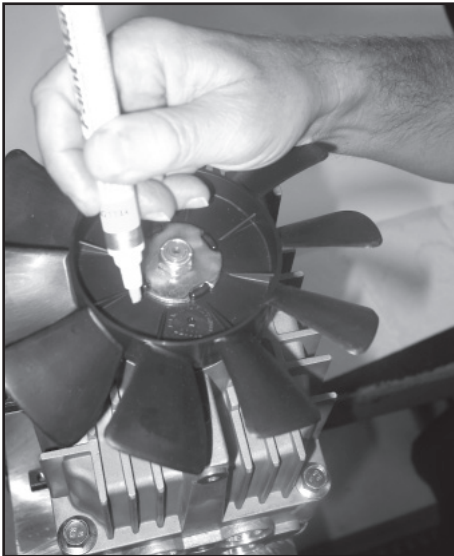

**Mark assembly for alignment**

2. Place an alignment mark on the side of the fan assembly and onto the top of the charge pump cover. This will make reassembly easier.

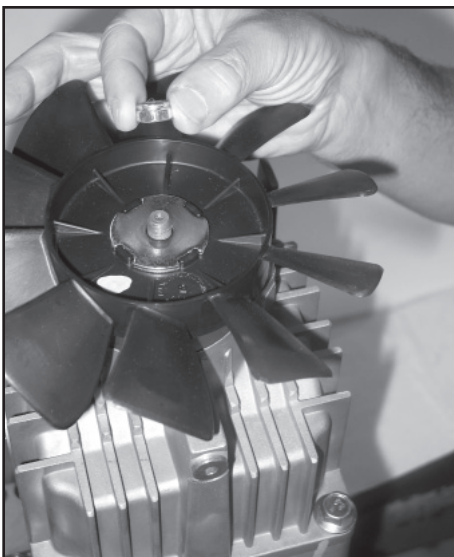

**Remove fan nut**

3. Remove 3/8-24 nylon insert nut from shaft using a 9/16" wrench. Lift out special washer and remove fan.

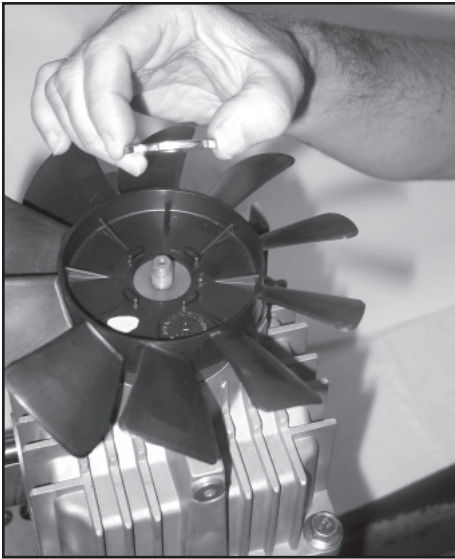

**Remove washer**

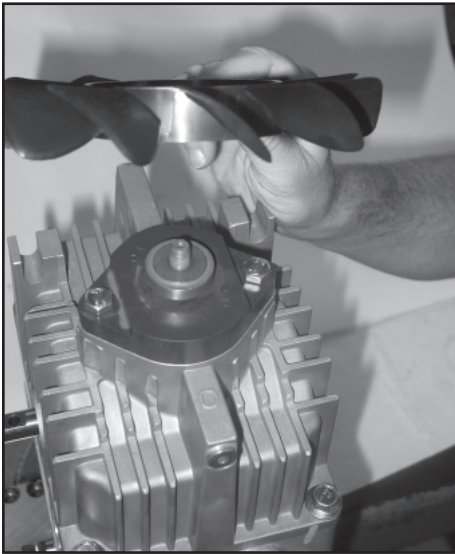

**Remove fan**

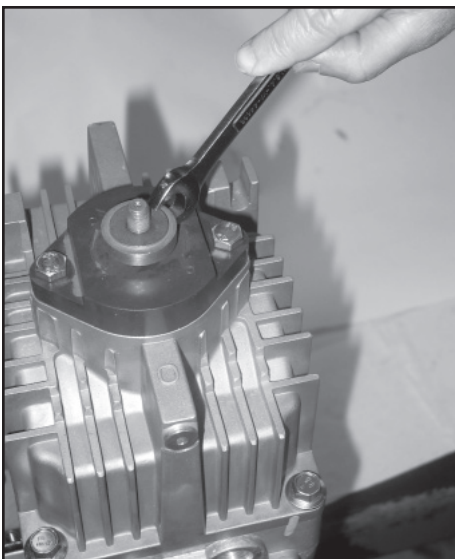

**Remove fan spacer**

4. Due to the taper in shaft, use an open end wrench to pry fan spacer from one side to the other until loosened, or use a small gear puller.

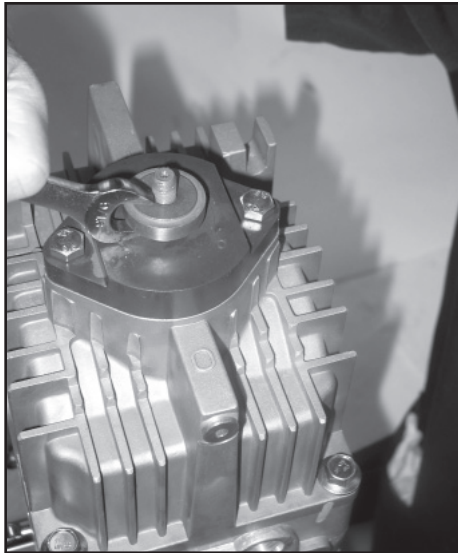

**Remove fan spacer**

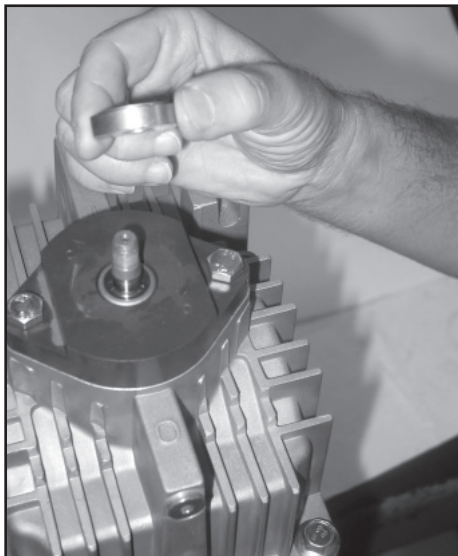

**Remove fan spacer**



**Mark charge pump cover to housing**

5. Place an alignment mark on the side of the charge pump cover to housing assembly. This will make reassembly easier.



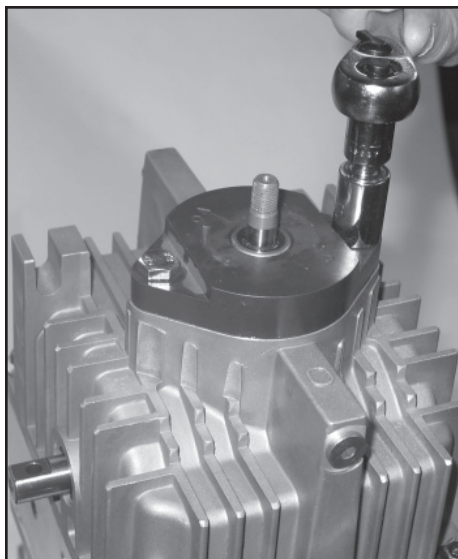

**Remove bolts**

6. Remove two M8 x 1.25 bolts (19) on charge end cover using a 13mm socket.

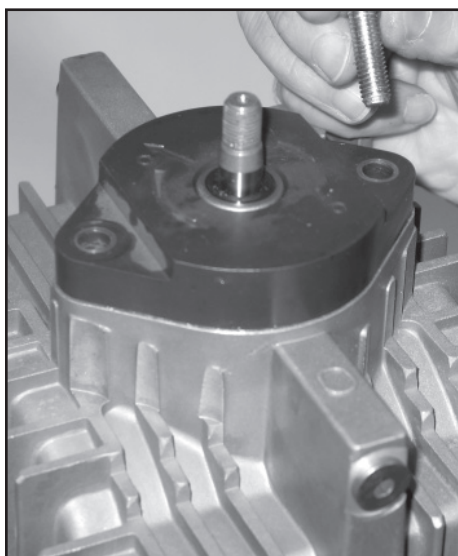

**Remove bolts**

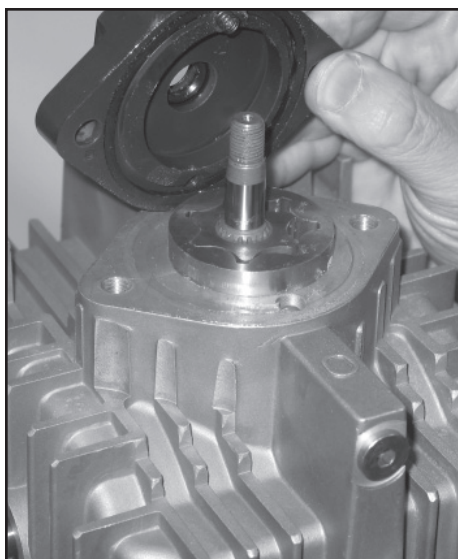

**Removal of charge cover**

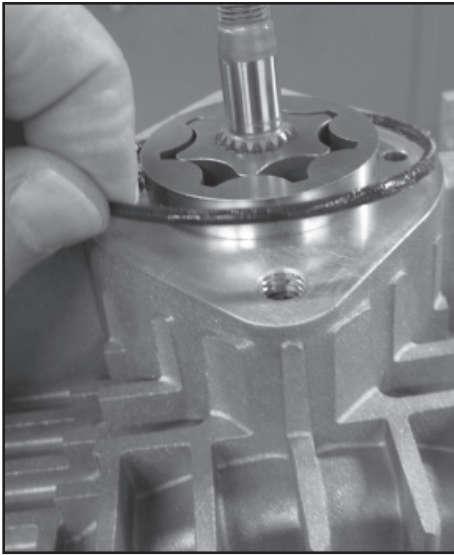

**Remove seal**

7. Watching for a loose ball and spring, lift off charge pump end cover. The O-ring (16) should be inside the base of the cover. Remove and inspect for damage.



**Remove spring**

8. Remove spring (14) and tip pump to remove plastic ball (15) in check valve.



**Lift off charge pump rotor set**

9. Lift off the rotor set (stator, rotor).

---

**CAUTION** Be very careful to not scratch or damage the charge surface on the rear housing as this will result in lower efficiency of charge pump when reassembled.

---

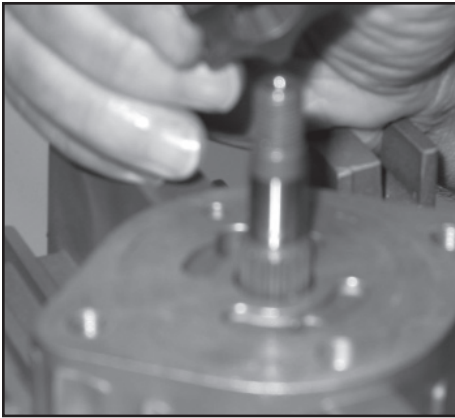

**Lift off charge pump rotor set**

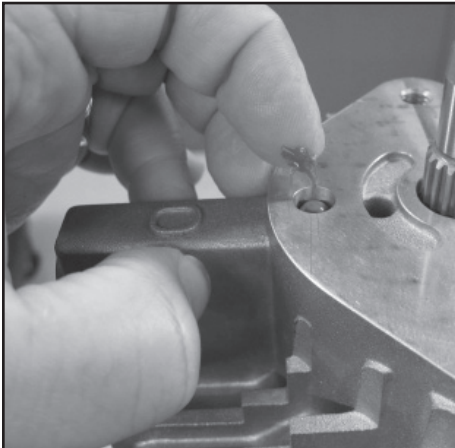

**Ball removal**

10. Using a small amount of grease, remove check ball (15) from rear housing.

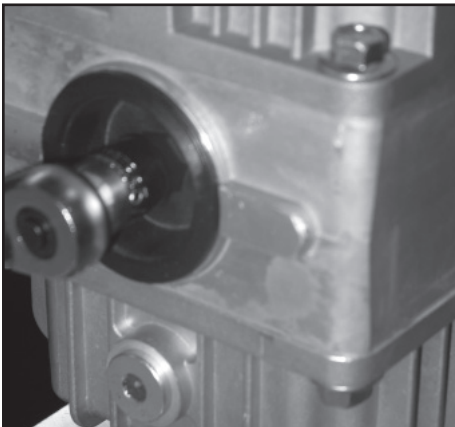

**Remove filter**

11. Using a 5/8" socket remove filter. Replace later during reassembly with a new filter.

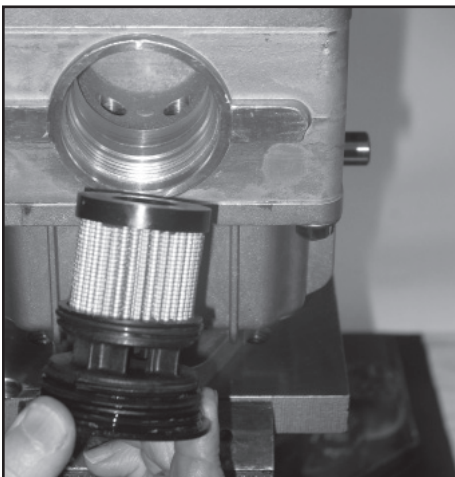

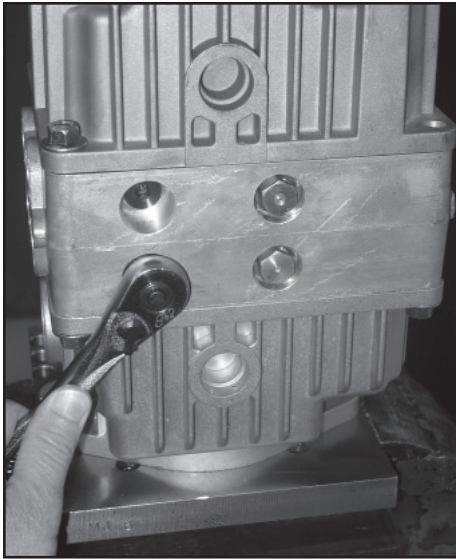

Check /shock valve removal

12. Remove shock (33), or check (34) valves on either side of the center block. (You will use:  
- 1/4" wrench insert for check valve  
- 11/16" socket on shock valves.)

---

**NOTE** Replace any valve that may have heavy wear marks on the seat area.

---

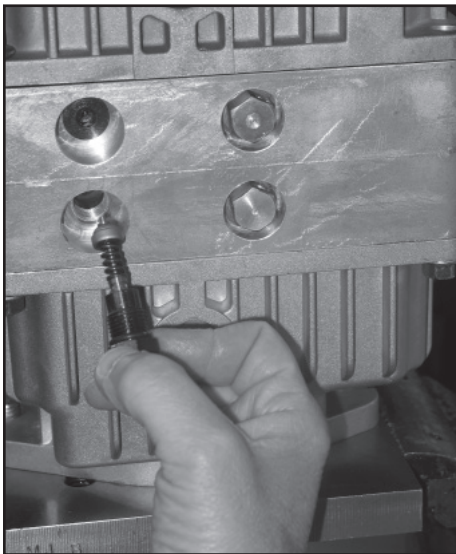

Check /shock valve removal



Check /shock valve removal

---

**NOTE** Lift out valve assembly and check for wear on valve seating surface and replace if necessary. Using a light source, check seats in center block for wear (heavy pitting marks on check valve cavity) or deformation of sealing surface.

---

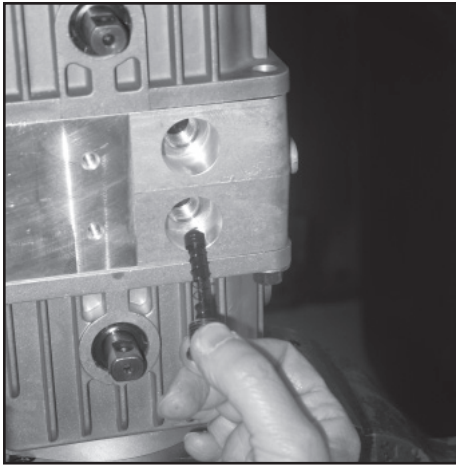

**Check /shock  
valve removal**

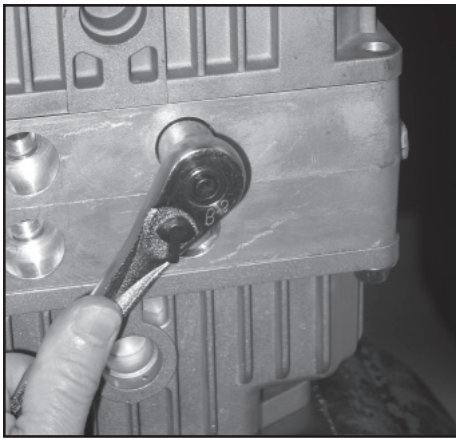

**Bypass valve  
removal**

13. Using a 5/8" socket, remove the bypass valves.

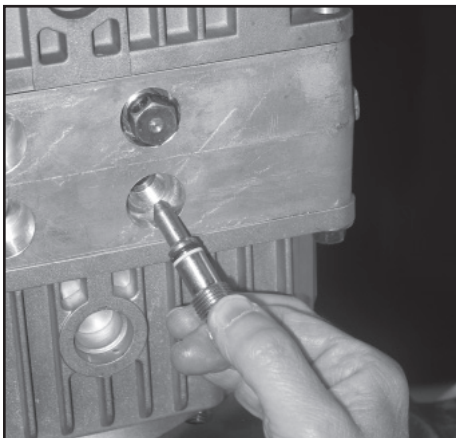

**Remove bypass  
valves**

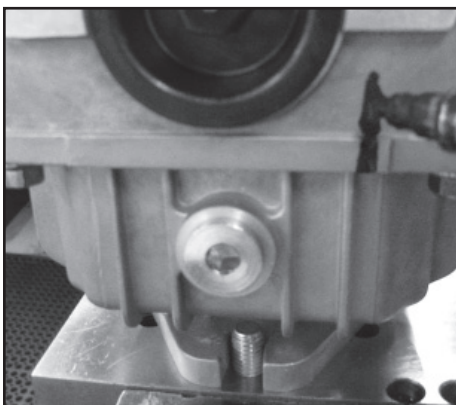

**Mark center block  
to rear housing**

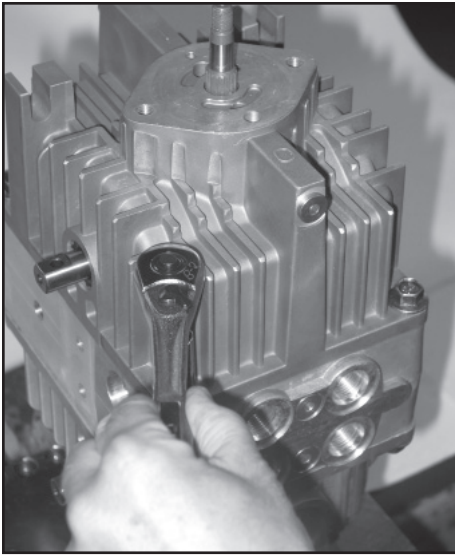

**Remove two (10mm) bolts from fan side adjacent to each other**

14. Using a 13mm socket remove two of the four bolts from the fan side housing block.

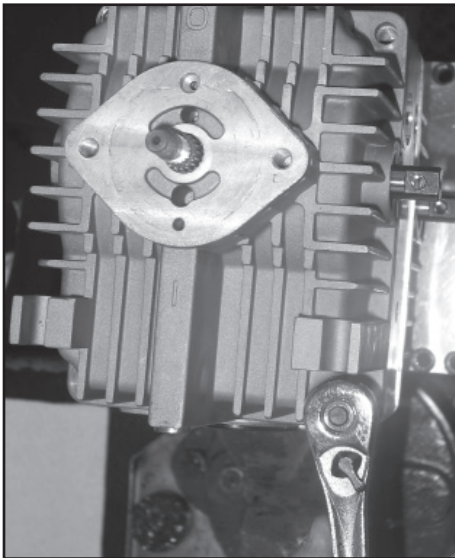

**Loosen two remaining bolts at fan side housing. DO NOT remove.**

15. Loosen slightly the two remaining bolts at the fan side housing block.

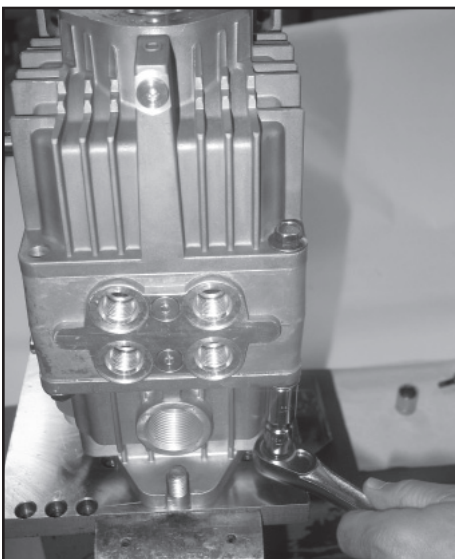

**Remove four (10mm) bolts from front housing**

16. Using a 13mm socket remove all four bolts from the front housing block.

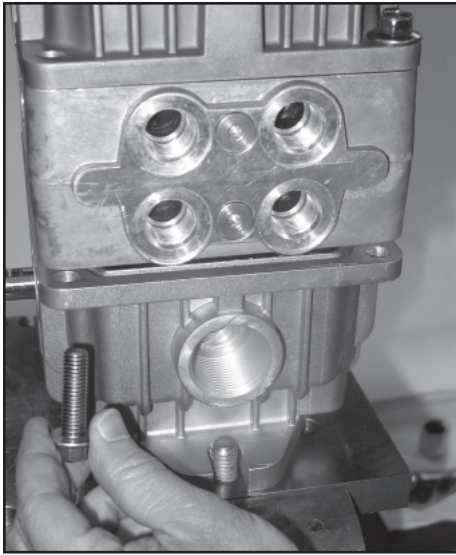

**Remove front housing bolts**

17. Using a gentle rocking motion, ease center block assembly (31) off shaft. Piston barrel assembly should be left in the housing.

---

**NOTE** The center block and rear housing assembly will still be bolted together. Turn upside-down to finish unbolting.

---



**Remove center block and rear housing**

---

**CAUTION** Take care not to damage the charge rotor area of the housing.

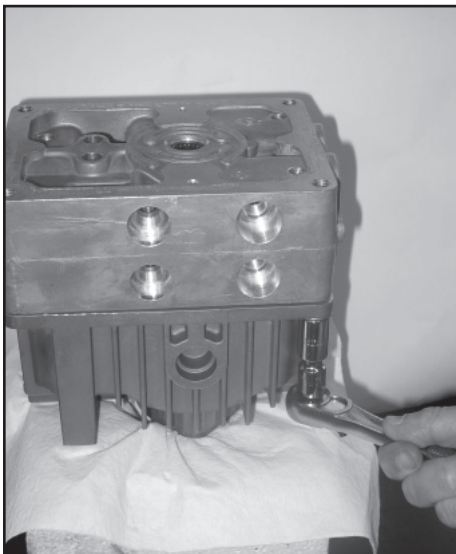

**Remove bolts from rear housing and center block**

18. Using a 13mm socket remove the two loosened bolts from the center block.



Remove bolts from rear housing and center block



Remove center block from rear housing

19. Using a gentle rocking motion, ease center block assembly (31) off shaft. Piston barrel assembly should be left in the housing.

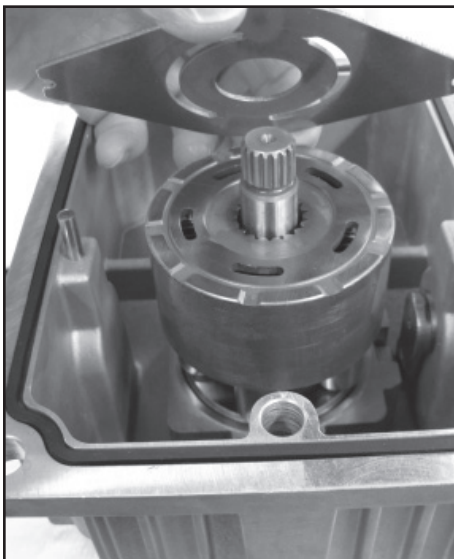

Remove and inspect rear port plate

20. Remove rear port plate. Dowel pins (13) may remain either inside the housing or come off with the center block. The port plate may stick to the housing or center block.

---

**NOTE** Be careful not to scratch the port plate or corresponding contact surface on the pump housing. Scratching will result in an improper seal.

---

Check for excessive wear on port plate (26), indicated by uneven scoring.



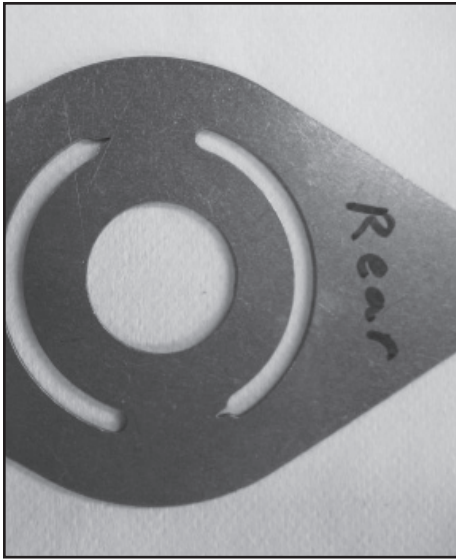

**Mark rear port plate**

21. Using a felt tipped marker, mark the rear port plate (26) on the steel side with "R" or "Rear" to aid in reassembly.

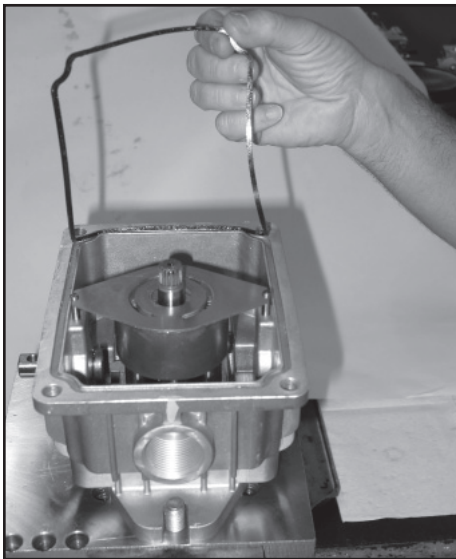

**Remove front and rear housing seals**

22. Inspect rubber housing seals for any damage or hardness. Replace if necessary.

---

**NOTE** Be careful not to scratch the port plate or corresponding contact surface on the pump housing. Scratching will result in an improper seal.

---

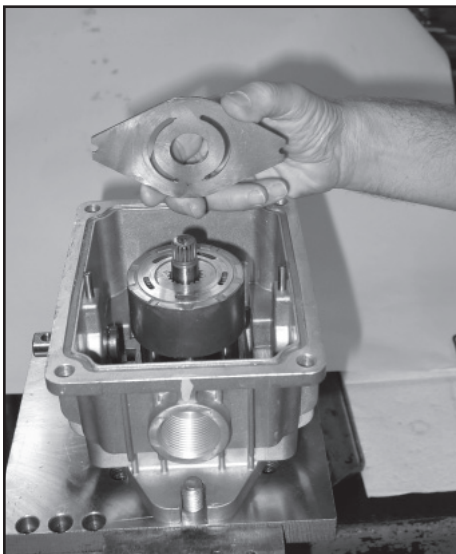

**Remove and inspect front port plate**

23. Check for excessive wear on port plate, indicated by uneven scoring.

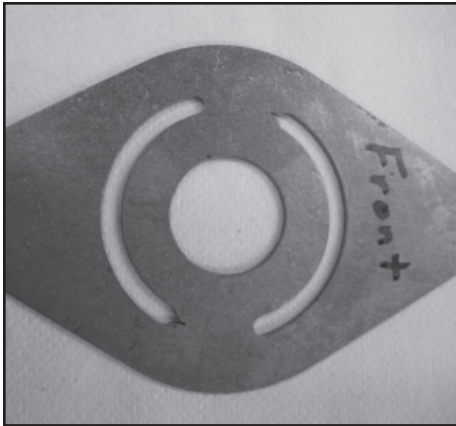

**Mark front port plate**

24. Using a felt tipped marker, mark the front port plate (26) on the steel side with "F" or "Front" to aid in reassembly.

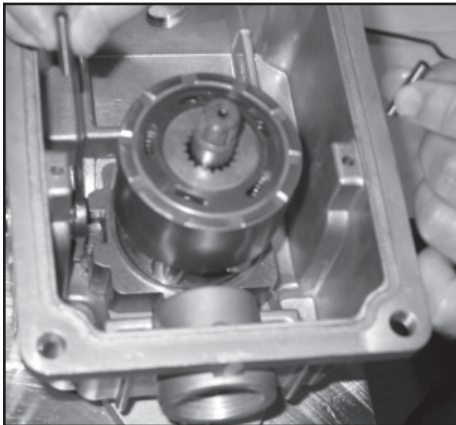

**Remove two dowel pins**

25. Remove two dowel pins (13) from each housing.

---

**NOTE** Steps 25 through 30 are the same for front and rear assemblies.

---

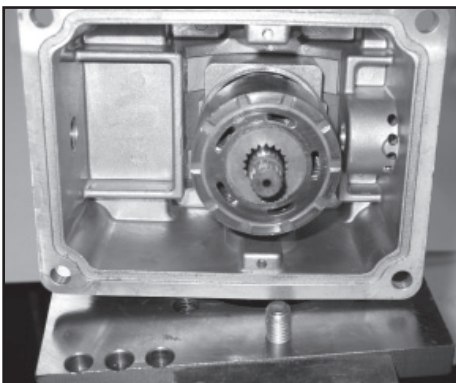

**Tilt housing assembly to side**

**Ease out piston and barrel assembly**

26. Cover assembly with hand and tilt to pour out excess oil. While holding pump at slightly less than a 90-degree angle, ease out piston and barrel assembly.

---

**CAUTION** Please refer to photo at left on angle. If pistons do fall back into pump, they could become damaged and the assembly would require replacement.

---

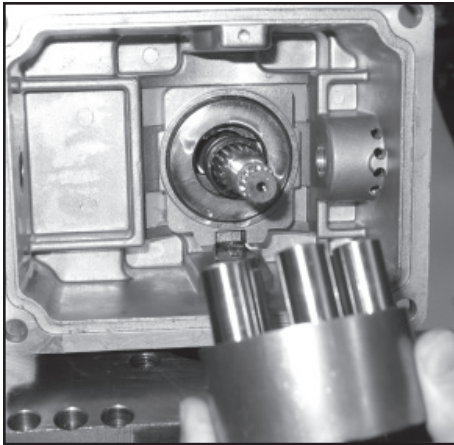

**Removal of piston and barrel assembly**

27. Check surface of rotating group and sides of pistons for excessive wear, indicated by scoring. Remove pistons and check bores and springs for signs of scoring. Check top and OD of pistons for pitting or scratch marks.

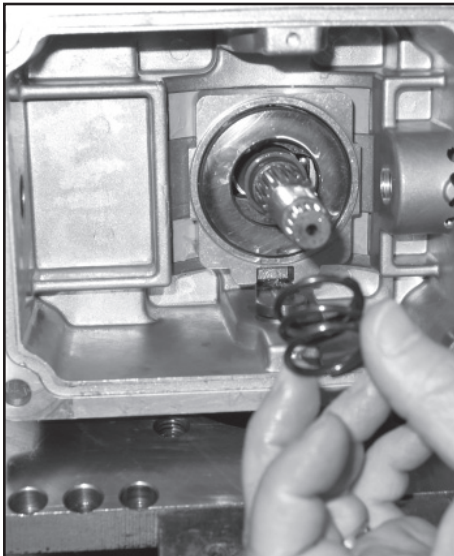

**Lift off central spring**

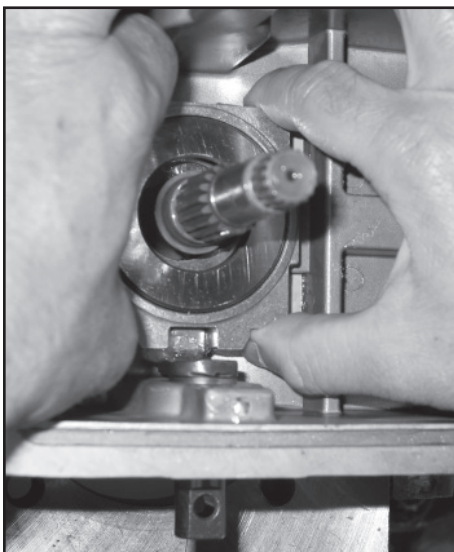

**Removal of thrust bearing assembly and swash block**

28. Remove thrust bearing assembly and swash block. Check top and bottom of surfaces for excessive wear.

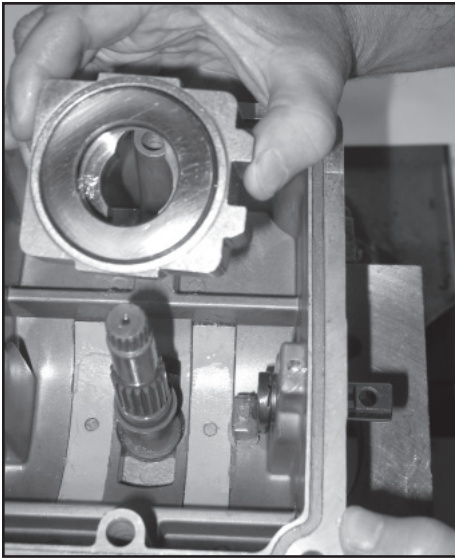

Removal of thrust bearing assembly and swash block

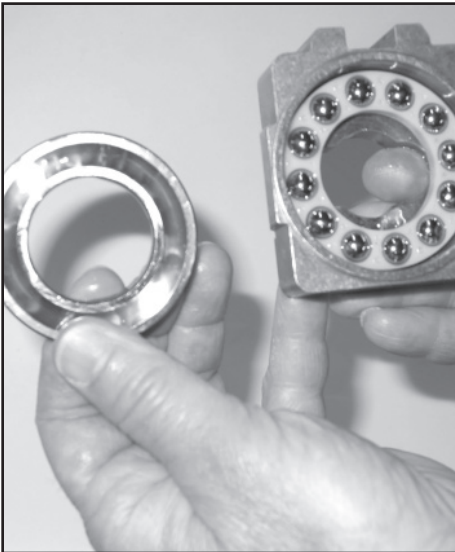

Remove thrust bearing assembly

29. Remove top washer of bearing race

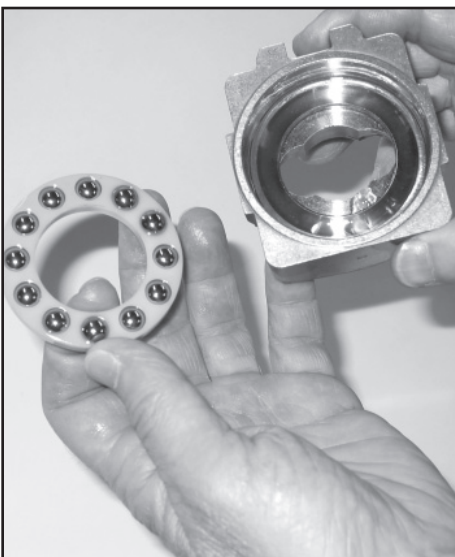

Remove bearing/cage and bottom race

30. Carefully remove bearing/cage and bottom race and check both the race and bearing/cage for wear and damage.

---

**NOTE** Check for spalling or galling on the balls and the cage for any damage.

---

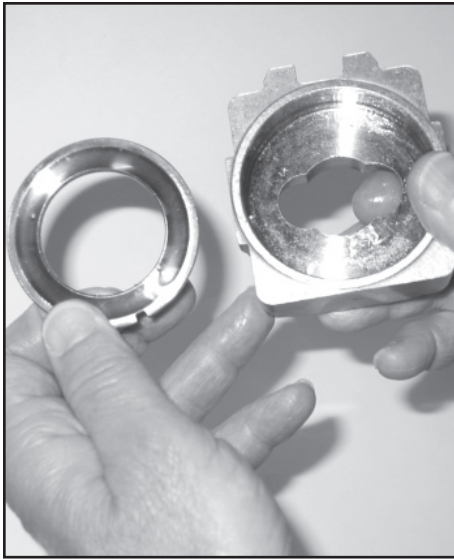

**Remove and check for wear**

31. Inspect lower thrust washer for any spalling, galling or heavy wear on the bearing race.

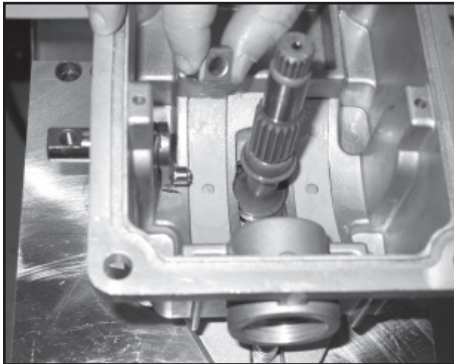

**Removal of control block**

32. Remove control block from trunnion arm.

---

**NOTE** Remove only if you detect a trunnion or shaft seal leak or for seal replacement.

---

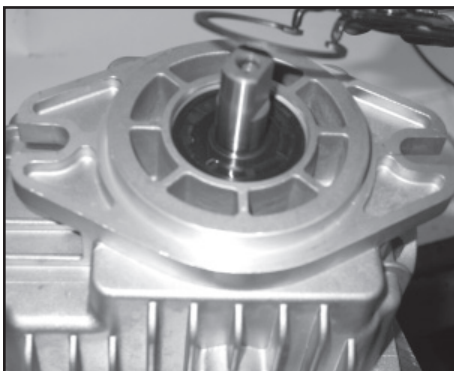

**Remove seal retaining ring**

33. To remove the retaining ring holding the seal in place, use internal snap ring pliers.

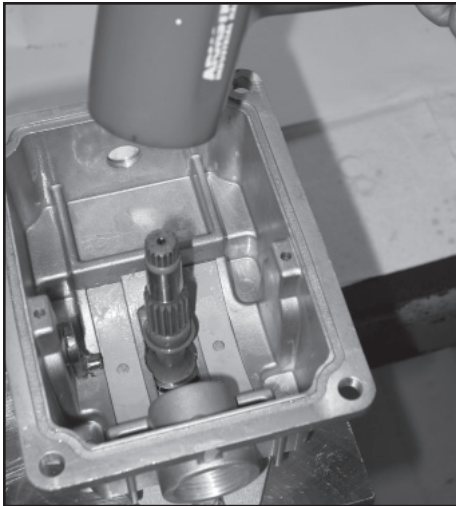

**Remove shaft**

34. Remove pump assembly from vise and hold with shaft approximately two to four inches above work table surface. Tap top of shaft with a soft mallet to loosen. Keep assembly as level as possible so as not to damage shaft and housing. When shaft is free from assembly, the washer and seal will fall away.

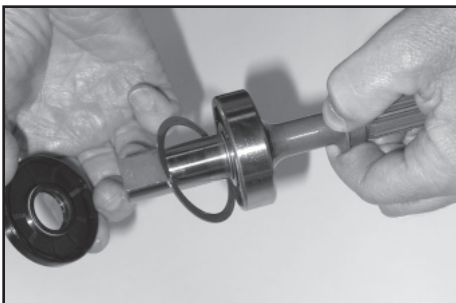
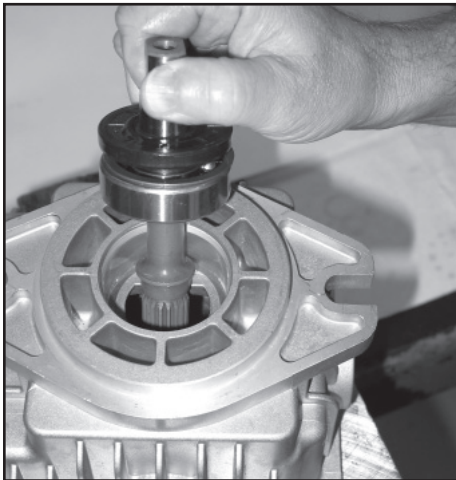

**Shaft seal and seal washer**

35. Replace shaft seal (4) and seal washer (18) if necessary due to seal leak.

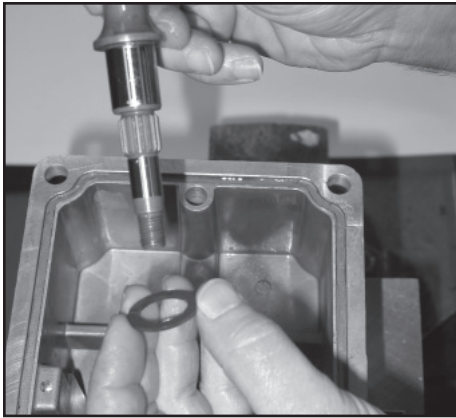

**Rear shaft and washer removal**

---

**NOTE** This washer is only used on the rear housing assembly.

---

36. Remove shaft (5) from rear housing. Shaft washer (24) should come out with shaft.

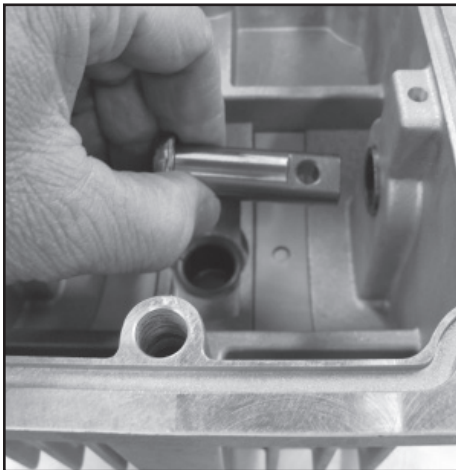

**Trunnion arm removal**

37. Pop out trunnion arm from front and rear housings by applying pressure from outside the pump housing.

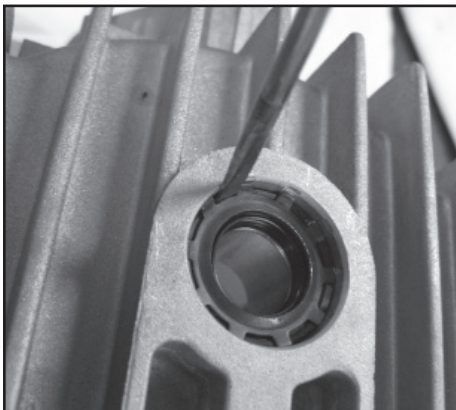

**Retaining ring removal**

38. To remove the retaining ring holding the trunnion seal in place, use a small flat head screwdriver to pop out the ring. Pry out the seal and discard.

---

**NOTE** Small bore will be scored from removing the retaining ring. These sharp edges must be removed with emery paper prior to pressing in a new seal.

---



**Trunnion seal removal**

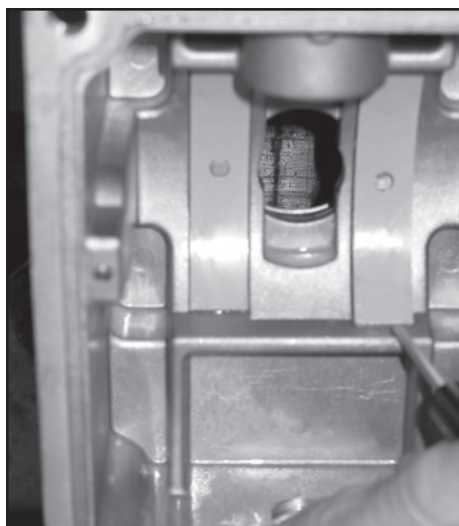

**Inspection of cradle bearing**

---

**NOTE** Bearing strips are in the bottom of each housing assembly. Bearing strips are removable, but if not damaged can be reused and would not require removal.

---



**Removal of cradle bearings**

39. Remove cradle bearings only if necessary. Cradle bearings can be removed using either a strong magnet or a small flat head screwdriver.



**Assembly Preparation**

Clean and liberally lubricate all parts prior to reassembly to ensure contact and sealing.

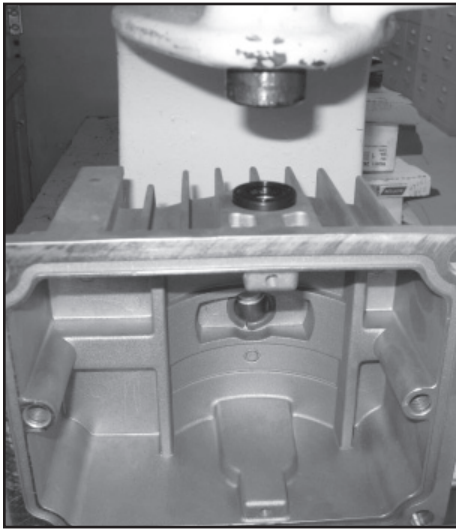

**Press in trunnion arm seals**

1. Using an arbor press and a socket with an O.D. of approximately 15/16", press in new trunnion arm seals.



**Press in seal retainers**

2. Using the same arbor press and socket, press in seal retainer. Teeth on O.D. of retainer point up at an angle

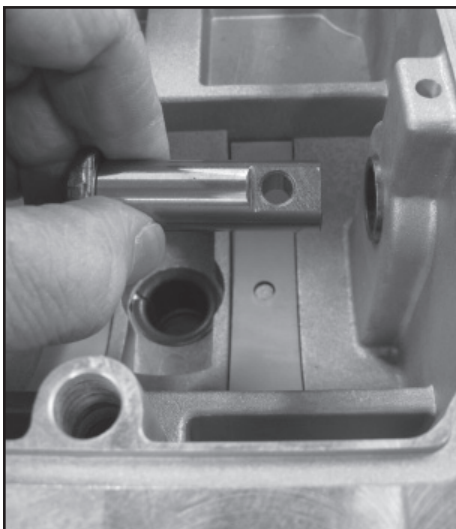

**Install trunnion arms**

3. Slide trunnion arm through housing and seal using a twisting motion to prevent cutting the seal. Install both front and rear trunnion arms.

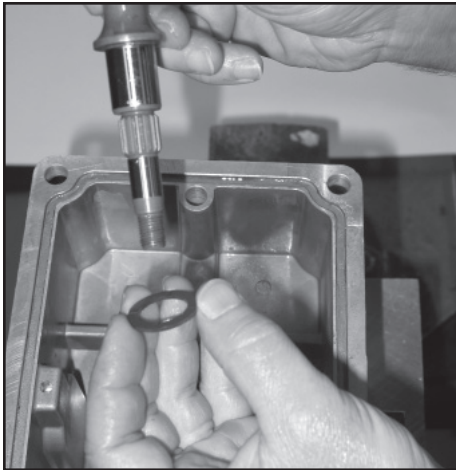

#### Rear shaft and washer installation

4. Place washer (24) onto shaft (5) and install into rear housing.

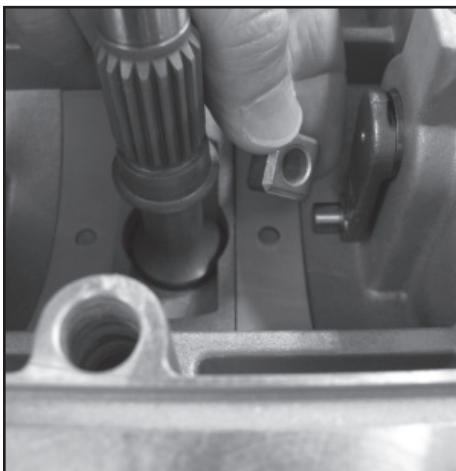

#### Install rear control block

5. Install control block (9) onto tip of trunnion arm in rear housing.

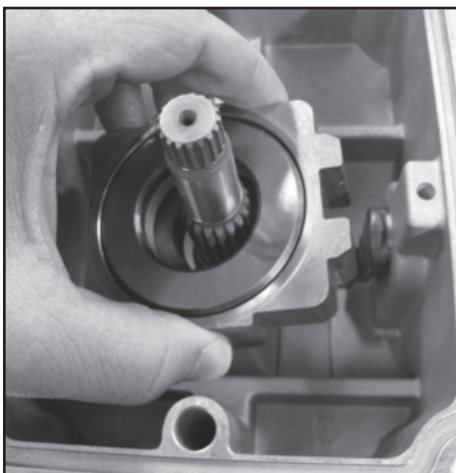

#### Install rear swash block

6. Align swash block (8) with control block (9) using a small screwdriver. Slide block over shaft (24) and control block. Verify swash block is over both cradle bearings and moves freely.

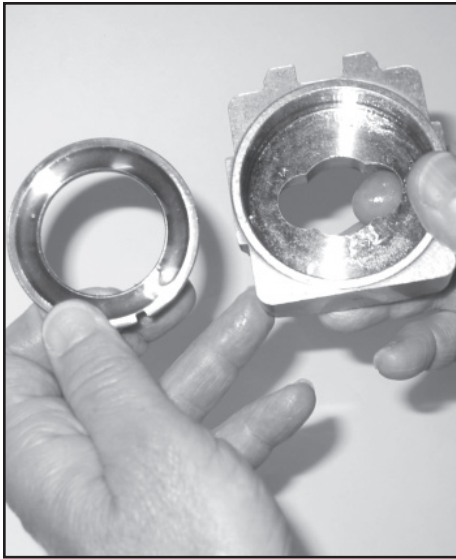

**Place bottom bearing race into place**

8. Place bottom bearing race (2) into place, aligning notch with pin, if pin is present.

---

**NOTE** The bottom race is the thinner of the two races.

---

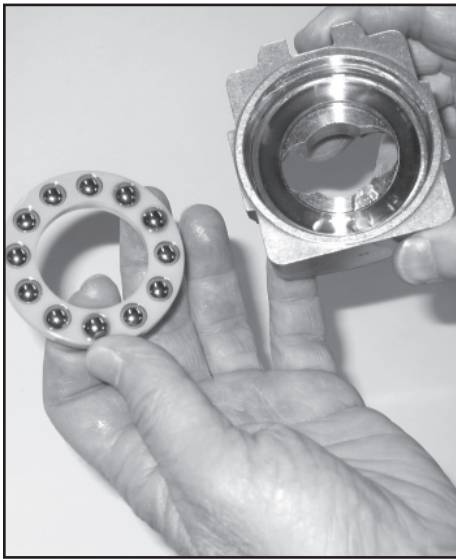

**Install bearing/cage assembly**

9. Install bearing cage (2) into race. Cover with top bearing race.

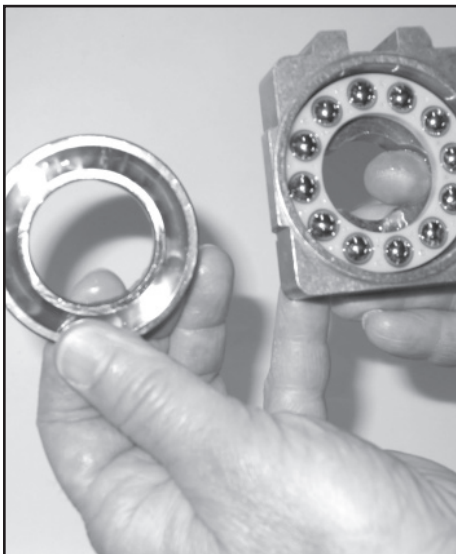

**Install top bearing race**



**Install central spring into rear housing**

10. Place spring (11) over rear shaft as shown.

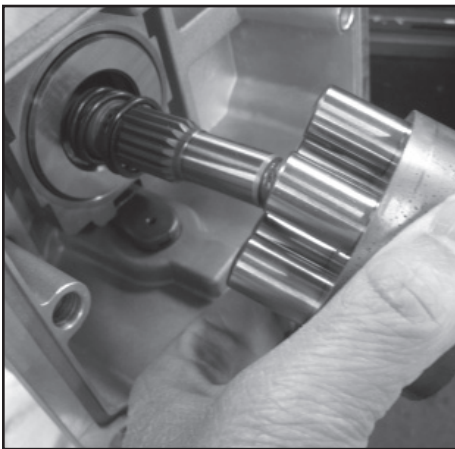

**Install rotating group into rear housing**

11. Tilt pump housing on side at slightly less than a 90-degree angle (see photo). Slide in assembly (21) over shaft splines and return pump to upright position.

---

**NOTE** Ensure that the pistons do not fall out of the barrel.

---

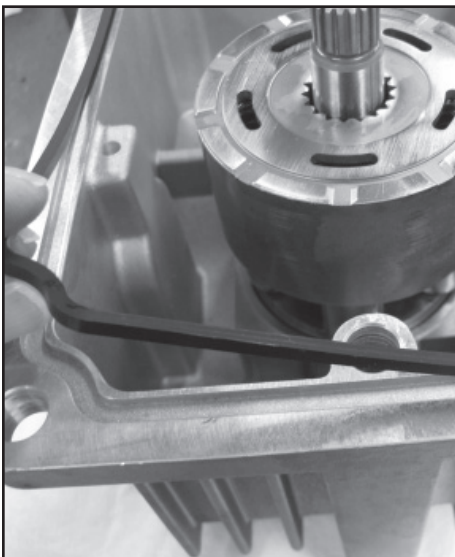

**Place housing seal into groove**

12. Liberally lubricate housing seal (3) and place in groove. Make sure it is flat by running fingers around top (see photo.)

---

**NOTE** Seal can be pinched easily by housing if not secure in groove.

---

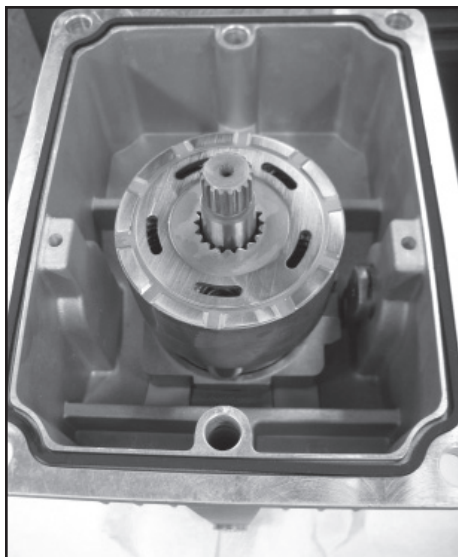

**Make sure seal is flat in groove**

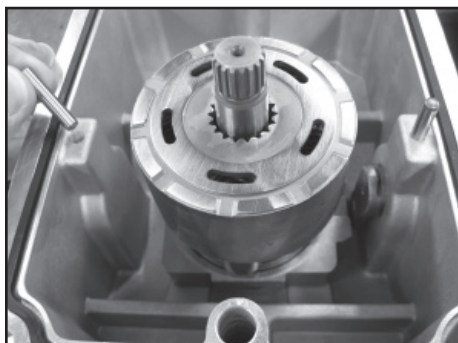

**Place two alignment pins into rear housing**

13. Place two alignment pins (13) into rear housing.

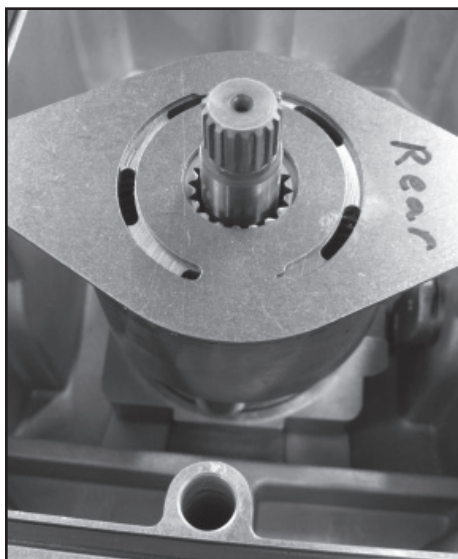

**Place port plate marked "Rear" steel side up on top of rotating group**

14. Place the port plate (26) marked "Rear" steel side up on top of the rear housing rotating group. Align the notches at each end of the port plate on the alignment pins in the housing.

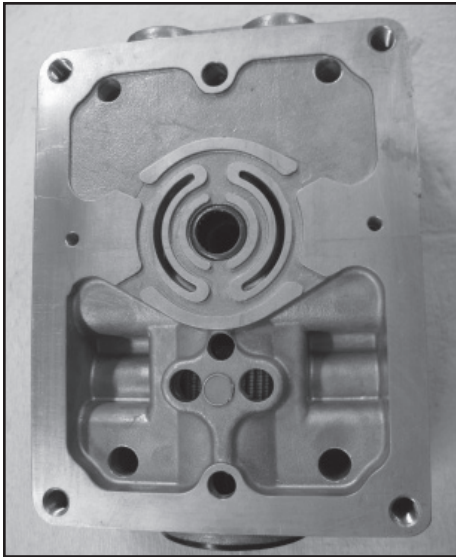

**Rear side of center block**

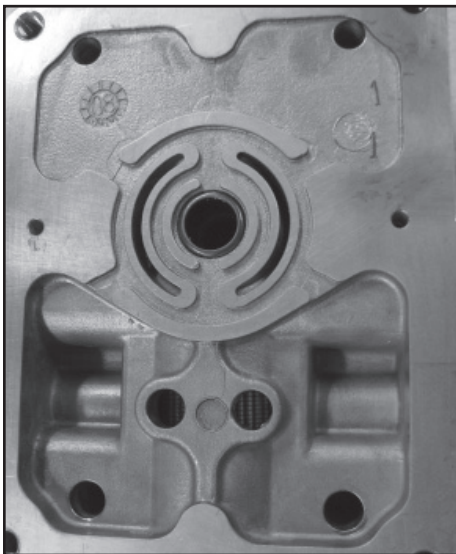

**Front side of center block**

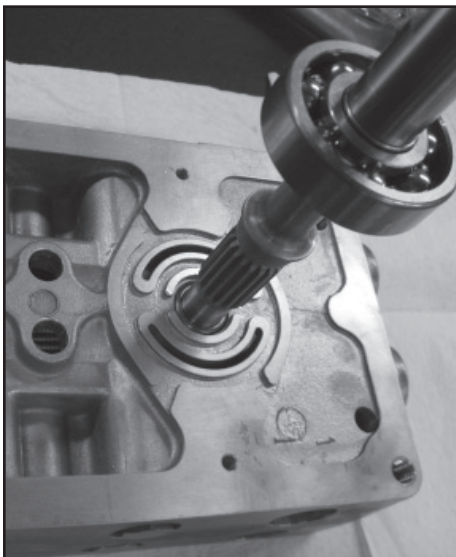

**Insert shaft into front side of center block**

15. Insert the splined section of the front shaft into the front of the center block. Align the splines of the shaft to the shaft coupler between the two bearings.

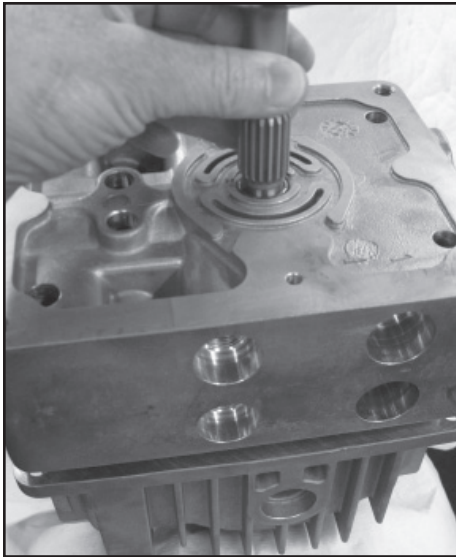

**Align center block to rear housing**

16. Place center block and front shaft onto rear housing. Rotating the front shaft, align the splines on the rear shaft to the coupler. Press straight down on the center block as the front shaft is turned.

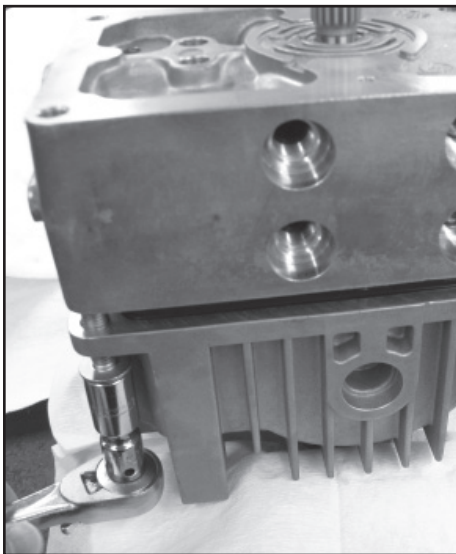

**Install bolts**

17. Install two of the four bolts diagonally into the rear housing and tighten alternately. Make sure that the rear shaft is still aligned to the coupler by rotating the front shaft.

---

**NOTE** If you feel a drag while tightening, back that side off 1/2 turn and tighten opposing side a full turn. Try the side that had a drag again.

---

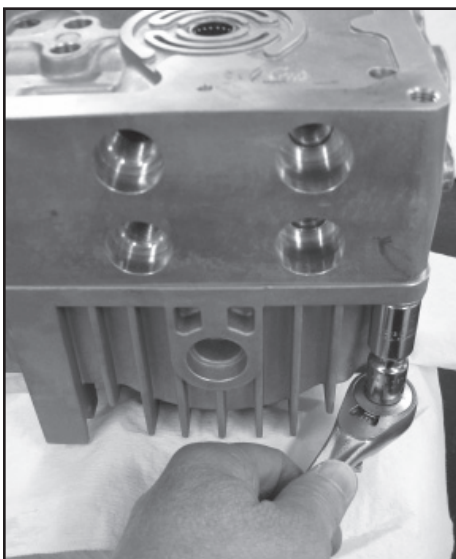

**Tighten bolts**

18. Install the other two bolts into the rear housing and tighten all four bolts. Bolts will be torqued in a later step.

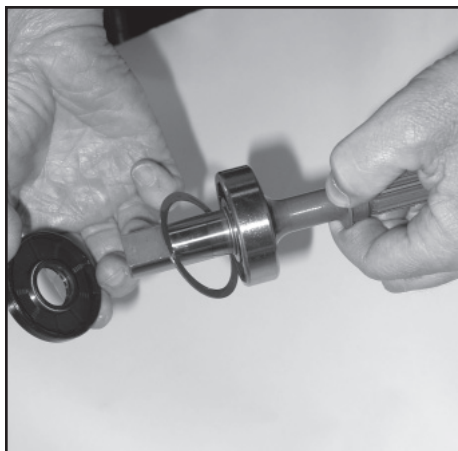

**Front shaft components**

---

**NOTE** Make sure front section trunnion arm is in place before proceeding to the next step.

---

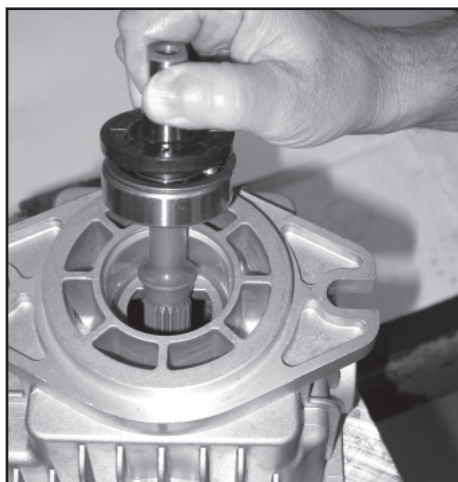

19. Place shaft (30) into front housing. Place washer (18) into housing. Lubricate I.D. and O.D. of shaft seal (4) and place on shaft. Take care not to cut or distort the seal I.D. as it is slid down over the shaft.

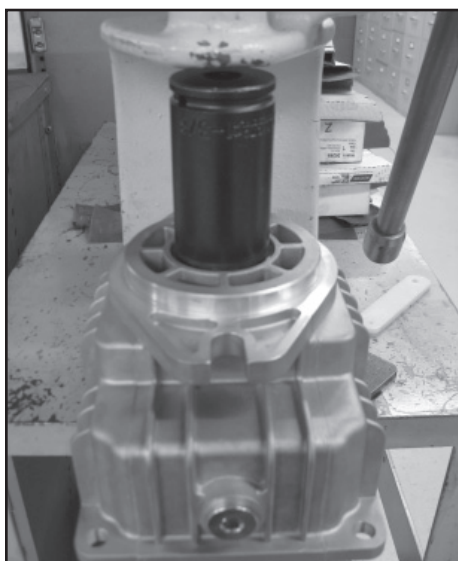

**Press shaft seal into place**

20. Using a press tool and a deep well socket with an outside dimension of about 1.9", press the seal just past the snap ring groove.



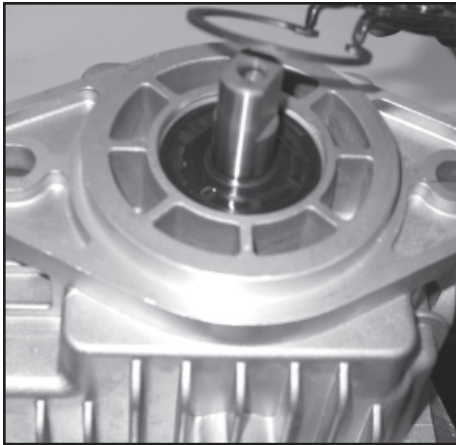

**Install snap ring**

21. Using internal snap ring pliers, put snap ring (10) in place.

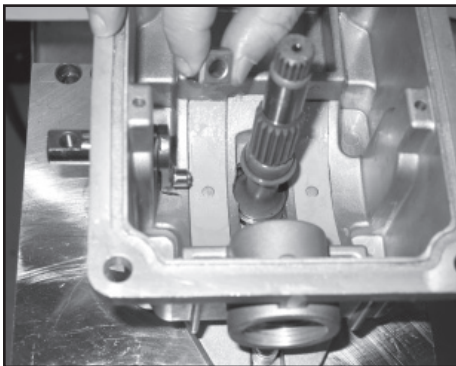

**Install control block**

22. Install control block (9) onto tip of trunnion arm in front housing.

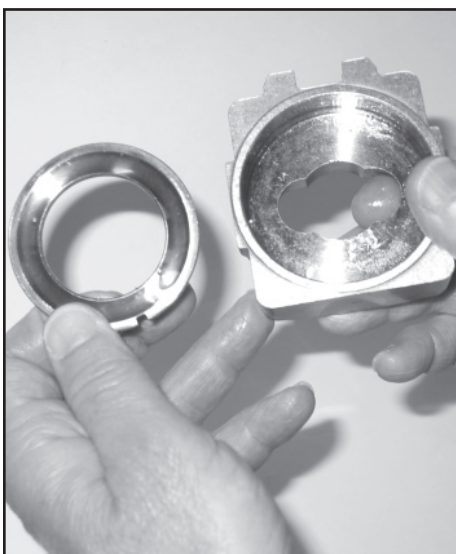

**Place bottom bearing race into swash block**

23. Place bottom bearing race (2) into place, aligning notch with pin, if pin is present.

---

**NOTE** The bottom race is the thinner of the two races.

---

Install bearing cage (2) into race. Cover with top bearing race.

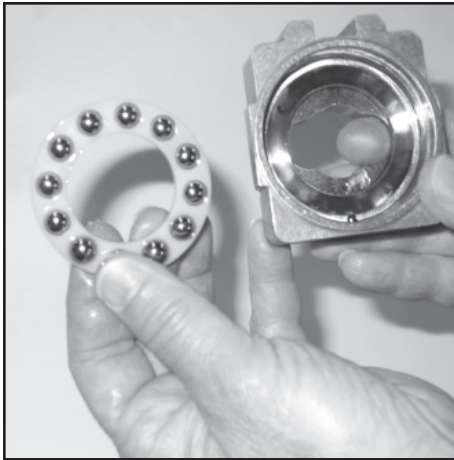

**Install bearing/  
cage assembly**

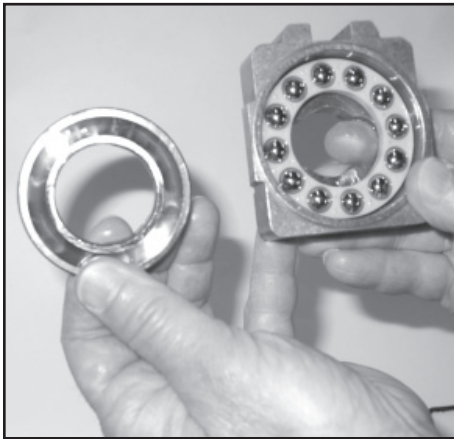

**Install top bearing  
race**

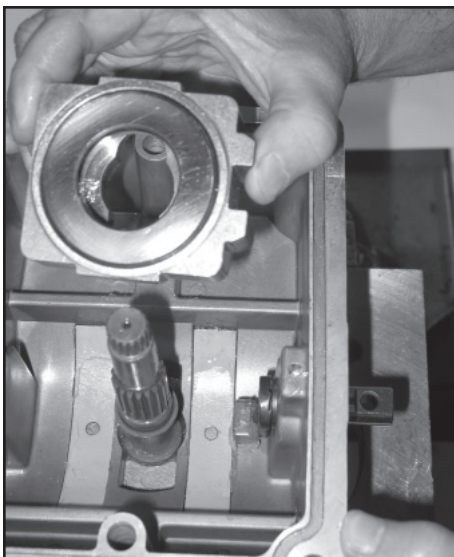

**Install swash  
block/thrust  
bearing assembly**

24. Align swash block (8) with control block (9) using a small screwdriver. Slide block over shaft (24) and control block. Verify swash block is over both cradle bearings and moves freely.

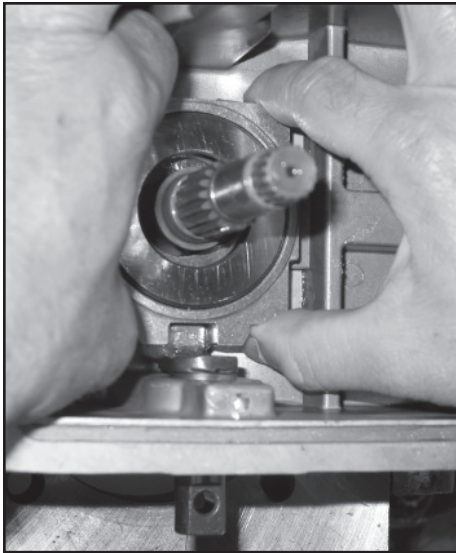

Install swash block/thrust bearing assembly

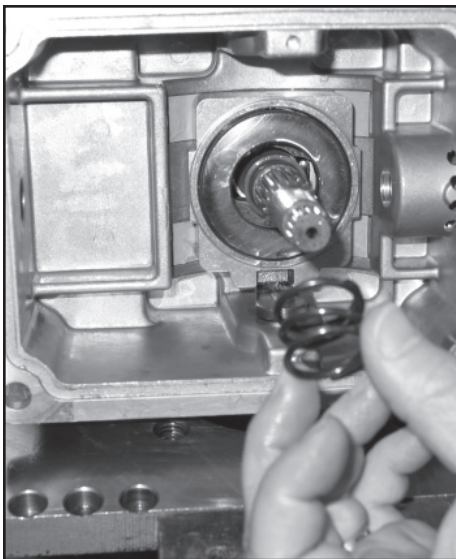

Install central spring

25. Place spring (11) over shaft as shown.

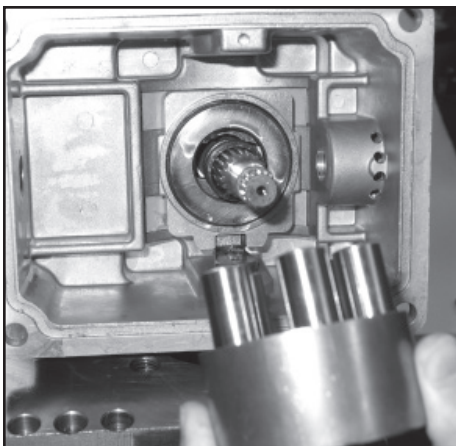

Install rotating group

26. Tilt pump housing on side at slightly less than a 90-degree (see photo). Slide in assembly (21) over shaft splines and return pump to upright position.

---

**NOTE** Ensure that the pistons do not fall out of the barrel.

---

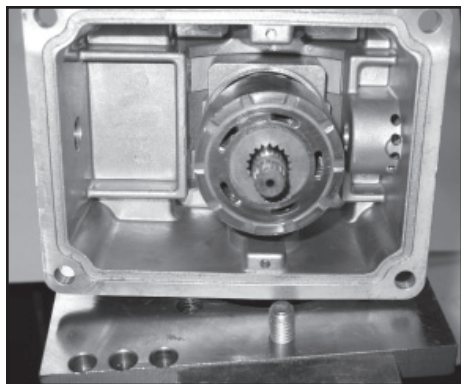

**Installed rotating group**

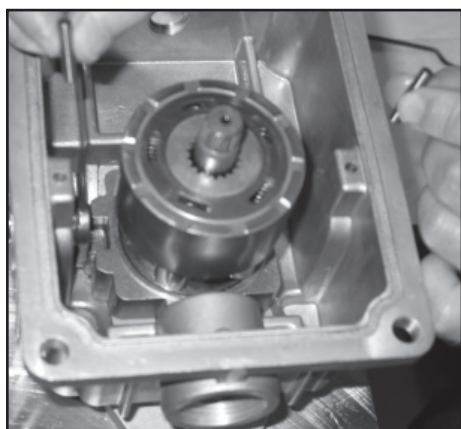

**Place pins in front housing**

27. Place two alignment pins (13) into front housing.

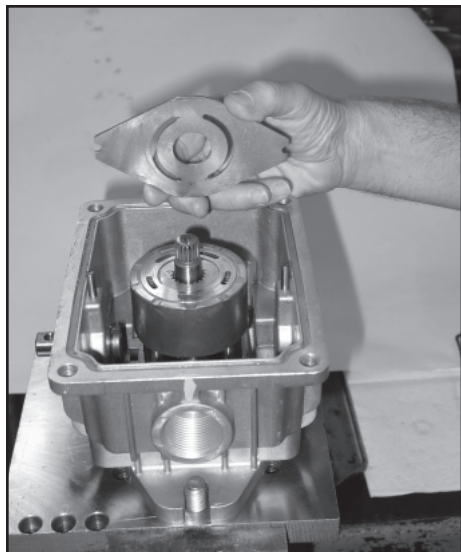

**Place port plate marked "Front" on top of rotating group**

28. Place the port plate (26) marked "Front" steel side up on top of the front housing rotating group. Align the notches of the port plate on the alignment pins in the housing.

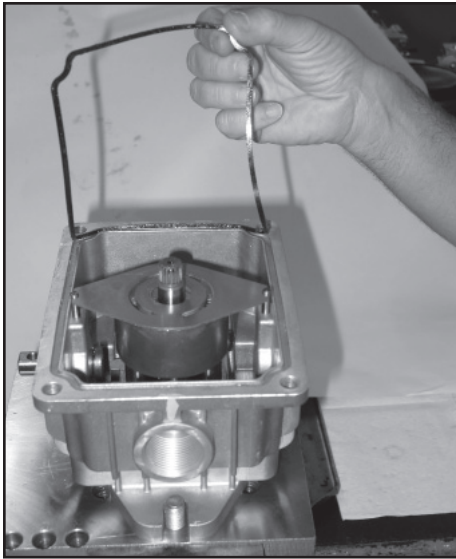

**Place housing seal into groove**

29. Liberally lubricate housing seal (3) and place in groove. Make sure it is flat by running fingers around top.

---

**NOTE** Seal can be pinched easily by housing if not secure in groove.

---



**Align center block to front housing**

30. Place center block/rear housing assembly onto front housing. Rotating the front shaft, align the splines on the front shaft to the coupler. Press straight down on the rear housing as the shaft is turned.

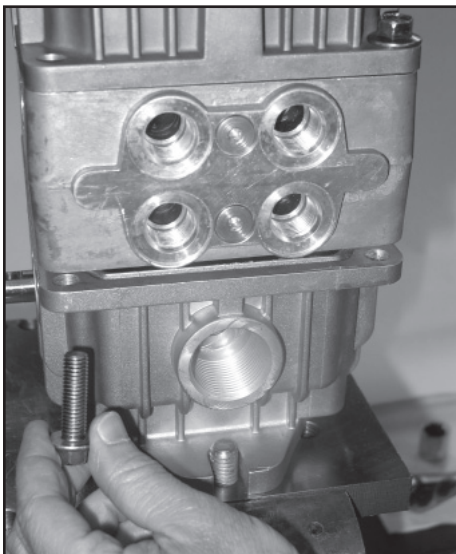

**Install bolts**

31. Install two of the four bolts diagonally into the front housing and tighten alternately. Make sure that the front shaft is still aligned to the coupler by rotating the front shaft.

---

**NOTE** If you feel a drag while tightening, back that side off 1/2 turn and tighten opposing side a full turn. Try the side that had a drag again.

---

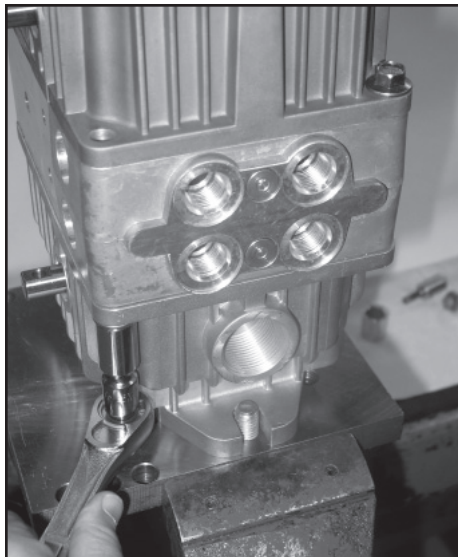

**Tighten and torque bolts**

32. Install the other two bolts into the front housing and tighten all four bolts. Torque all eight housing bolts to 31.9–38.6 Nm (282–342 in/lbs).

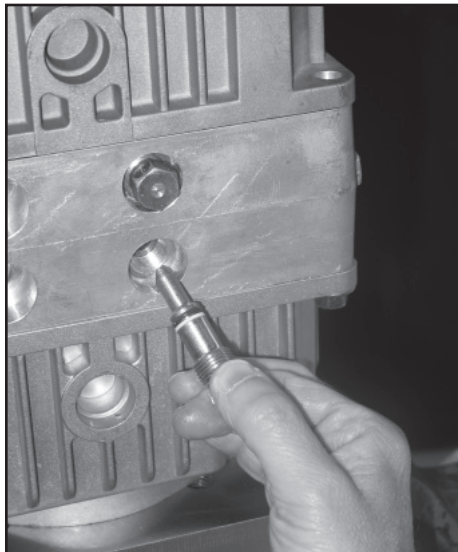

**Install two bypass valves**

33. Liberally lubricate bypass valves around seal area. Hand tighten and torque to 18.1–22.6 Nm (160–200 in/lbs).

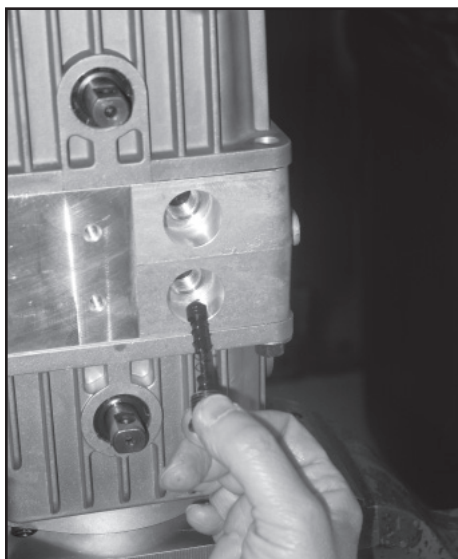

**Install shock valves or check valves (depending on model)**

34. Install shock (33) or check (34) valves (depending on model). Hand tighten and use an 11/16" or 1/4" allen wrench to tighten down. Torque all four shock/check valves to 18–22 Nm (160–200 in/lbs).

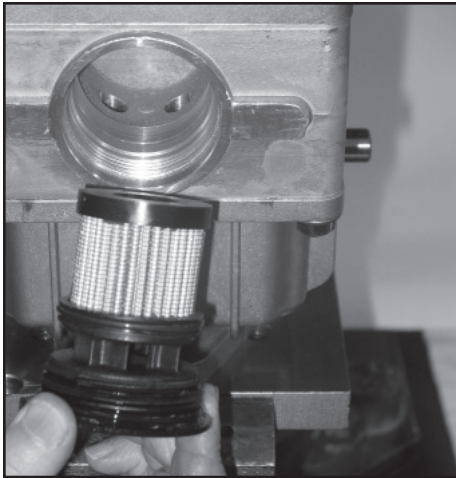

**Install filter element**

35. Lubricate both o-ring seals on filter assembly and hand tighten into center block.

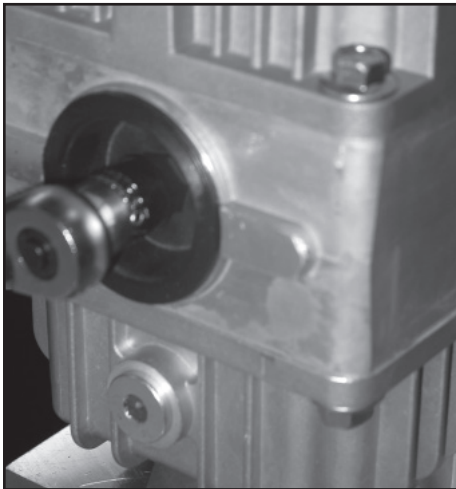

**Tighten filter element**

36. Tighten filter assembly using a 5/8" socket wrench. Torque filter to 12.4–15.8 Nm (110–140 in/lbs).



**Install charge relief ball**

37. Replace plastic ball (15) in counter bore charge relief port closest to A and B ports.



**Install charge rotor set**

38. Place rotor and stator over the shaft aligned with the splines of shaft.

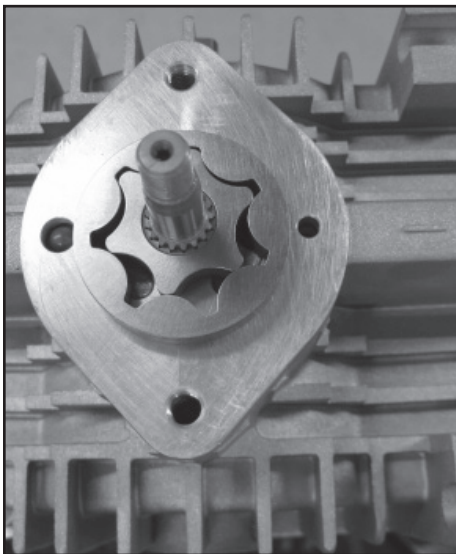

**Charge rotor set installed**

39. Install new o-ring (16) in charge cover.

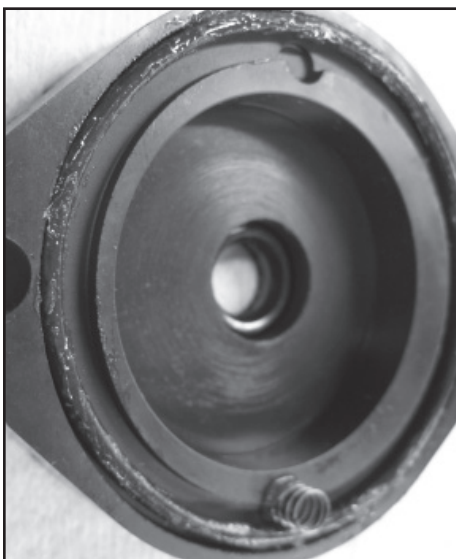

**Install o-ring and spring in charge cover**

40. Use a small amount of grease to retain the spring (14) and place in charge relief hole in the charge cover corresponding to the charge relief ball in the rear housing.





**Align charge cover with marks**

41. Align charge cover with mark made during disassembly, ensuring that spring aligns with check ball.

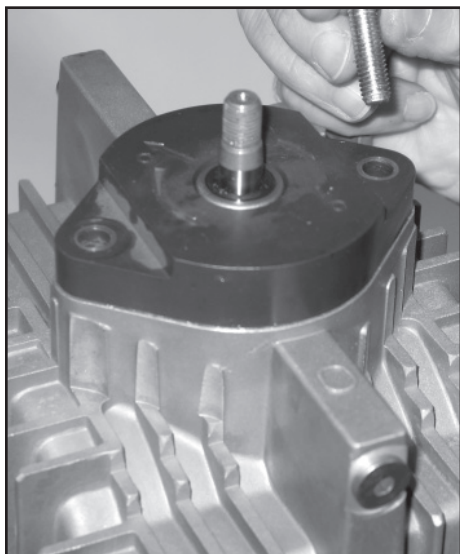

**Install bolts**

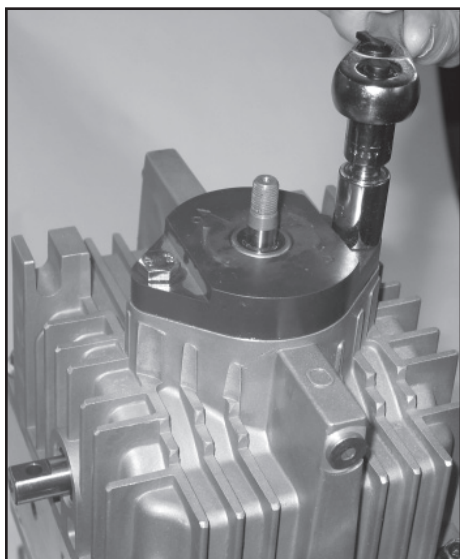

**Hand tighten bolts**

42. Drop in two bolts (19) and hand tighten. Torque to 17.5–21.5 Nm (155–190 in/lbs).

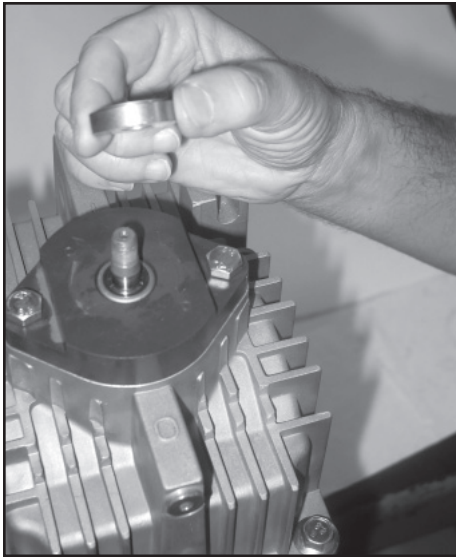

**Install fan spacer**

43. Place fan spacer (23) on shaft with mill groove facing up.

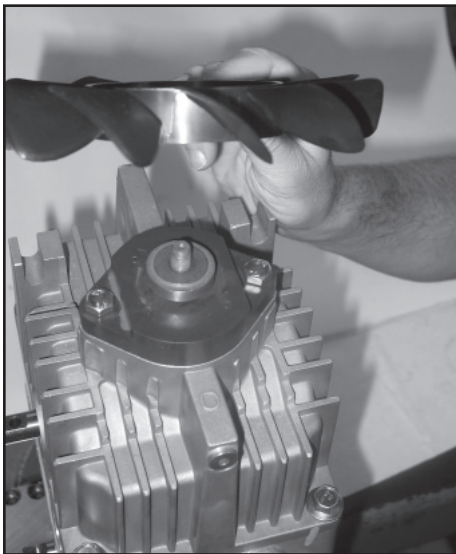

**Place fan on spacer**

44. Slide fan (32) onto shaft with code imprint in center facing up. Place special washer (21) on shaft, positioning so that the tabs fit into indentions in fan's center.

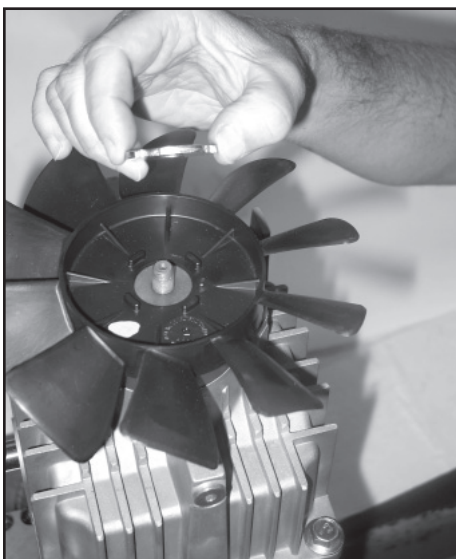

**Place special washer on fan**

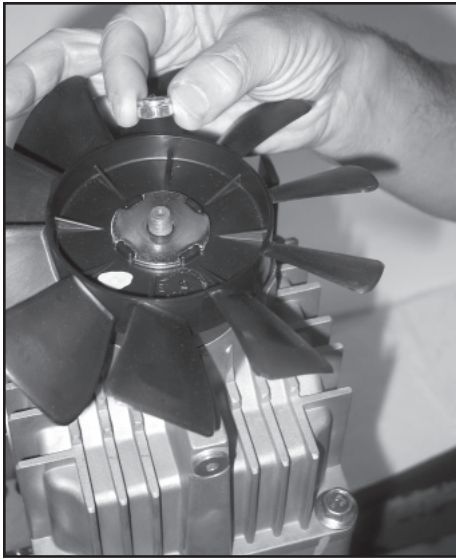

**Place nut on shaft  
and tighten**

45. Fasten one 3/8-24 nylon insert nut (22) on the shaft and tighten 10.8 Nm (100 in/lbs) with 9/16" wrench. Replace nylon nut if damaged. Nylon insert should be fully engaged.

## System Maintenance Tips

- Adjust fluid level in reservoir as necessary.
- Encourage all operators to report any malfunction or accident that may have damaged the hydraulic system or component.
- Do not attempt to weld any broken HP2 Tandem pump component. Replace the component with original equipment only.
- Do not cold straighten, hot straighten, or bend any HP2 Tandem pump part.
- Prevent dirt or other foreign matter from entering the hydraulic system. Clean the area around the filler caps before checking oil level.
- Investigate and correct any external leak in the hydraulic system, no matter how minor the leak.
- Comply with manufacturer's specifications for cleaning or replacing the filter.



**CAUTION** Do not weld, braze, solder or in any way alter any HP2 Tandem pump component.

---



**CAUTION** Maximum operating pressure must not exceed recommended HP2 Tandem pump pressure capacity.

---



**CAUTION** Always carefully inspect any system component that may have been struck or damaged during operation or in an accident. Replace any component that is damaged or that is questionable.

---



**CAUTION** Do not force any coupling onto the HP2 Tandem pump coupling shaft as this could damage the unit internally.

---

Parker Pump/Motor Operation extends close technical cooperation and assistance. If problems occur which you cannot solve, please contact our service department at (423) 639-8151, or your local Parker approved distributor.

## Final Checks

- Using an adjustable wrench, place on the flats of shaft (30) and make sure the shaft turns freely prior to installing on equipment.
- Pressurize the case drain port for 25 PSI dry air or nitrogen and submerge in solvent to check for external leaks. Make sure to plug the remaining ports prior to submerging.
- Check HP2 Tandem pump for rotation. Torque required to rotate coupling shaft should not be more than 50 lb/ft.
- Use test stand if available, to check operation of the HP2 Tandem pump.

## Hydraulic Fluids

Keep the hydraulic system filled with one of the following:

- 10W40 SE or SF, or manufacturer's suggested oil.
- Hydraulic fluid as recommended by equipment manufacturer, but the viscosity should not drop below 50 SUS or contain less than .125% zinc anti-wear additives.

**CAUTION**

Do not mix oil types. Any mixture, or an unapproved oil could deteriorate the seals. Maintain the proper fluid level in the reservoir. When changing fluid, completely drain old oil from the system. It is suggested also that you flush the system with clean oil.

---

## Filtration

Recommended filtration 20 micron, internal filter.

## Oil Temperature

Maximum operating temperature 230° F (110° C).







**Parker Hannifin Corporation**  
Hydraulic Pump/Motor Division  
2745 Snapps Ferry Road  
Greeneville, TN 37745 USA  
Tel. (423) 639-8151  
FAX (423) 787-2418  
[www.parker.com/pumpmotor](http://www.parker.com/pumpmotor)